

MARLIN

1971 E



MÄRKLIN-Fun

Why a MÄRKLIN HO Model Railroad

MÄRKLIN ELECTRIC TRAINS ARE BEST FOR . . .

- . . . the exciting first train. A beautiful gift box with sturdy locomotive, cars with automatic couplers, track oval and a powerful transformer. Everything assembles in minutes for the beginning of a lifetime hobby.
- . . . the exciting train that grows. This catalog shows hundreds of add on items. The smaller ones are best for the small beginning layout. All will be used in the larger model railroad to follow.
- . . . the train that's made to be played with. Small locomotives and cars are easy to put on the track, seldom come off the track even at high speed. All are copies of real railroad equipment, yet the track can be laid across the floor for playing with blocks and other toys.
- . . . the worlds largest assortment of trains and accessories. We developed HO trains in 1936 after 50 years experience with the larger gauges.
- . . . the miniature railway for people who want to run trains, not just look at them. If it can be done by the real trains it can be done by MÄRKLIN trains-real easily.

MÄRKLIN model railways offer features that are exclusive with our system:

- 1) The reliable current distribution of MÄRKLIN HO track.
- 2) The use of A.C. current for both trains and accessories.

These two features combine to provide you a model railroad that is always reliable and trouble free. With our simple A.C. transformers there is no need to know electrical wiring. Less wiring is required with the color coded, plug in system. Less cleaning of rails, wheels, gears and motors. No soldering needed, no special wire connecting clips.

MÄRKLIN HO Gauge Track

There are two types: the MÄRKLIN-M-(Metal) track and the MÄRKLIN-K-(Plastic) track. Both types offer the same reliable electrical distribution characteristics and are also equal in their ability to feed current from the center studs to the ski-type current pick ups on the locomotives.

The basic construction of the two types of track

differs. With the M-Track, perfectly formed black rails are mounted on an all metal roadbed featuring simulated ties and rock ballast. In contrast, the K-Track consists of finely detailed plastic ties into the bottom of which is inserted a metal center rail conductor in such a way as to allow only the points of the contacts to barely project, almost invisibly, upwards through the ties. The silver colored, metal profile rails are securely mounted onto the plastic ties.

There are three electrical connections on the M-Track. A sprung metal tongue on the center stud section and two all metal railjoiners at each end of the rails.

With the new K-Track, there are six mechanical connections as follows: 2 running rail joiners, two spring connectors for the center stud section and two snap connectors on the plastic tie base.

This MÄRKLIN stud contact system provides the most reliable current distribution for model railroads. The current is fed through the almost invisible center studs located in the center of the

ties, and is then led to the ski type current pick ups located on the bottom of the locomotives, the pickups being barely visible when the locomotive is on the track. Although contact between the pickup and only one stud point would be sufficient, the pickup actually rest on several contacts at one time, and therefore also keep the contacts always clean.

The path of the current is from the center studs to the pickup shoe, to the motor and then flows through all the locomotive and tender wheels to the running rails and finally back to the transformer. As you can see this provides a system that will give you good current pickup even when a certain part of the rails or wheels are dirty.

Because of this three rail system, any configuration of track can be laid, crossings, reverse loops, turning wyes, etc. without any special switches or wiring.

The MÄRKLIN track system is designed so that almost any layout form can be designed, yet a triple mainline layout, with sidings, will fit on a

YOUR FRIENDLY MÄRKLIN DEALER:

NICHOLAS SMITH

AUTHORIZED MÄRKLIN SALES & SERVICE STATION
60 NORTH 11 TH STREET

PHILADELPHIA, PENNSYLVANIA 19107

MINIMUM ORDERS \$10⁰⁰ PLEASE INCLUDE POSTAGE
AND INSURANCE ON ALL ORDERS

SHOP AT CENTER CITY HOBBY CENTER
WHERE 11 TH ST. CROSSES ARCH. ST.
ALWAYS A COMPLETE LINE OF YOUR RAILROAD NEEDS
SALES-SERVICE

MODEL RACE CAR SETS
CARS AND ACCESSORIES · SALES-SERVICE-PARTS

TEL. WA-5-7669 | TEL. WA-5-0521

ALL ORDERS SHIPPED OUT
SAME DAY AS RECEIVED

Penna, residents add 6% sales tax

150 10/7

See your dealer for all MÄRKLIN needs and repairs, as deliveries cannot be made from the factory to private parties. Sales are subject to change in manufacture and design. Measurements are given without guarantee. The publication of this catalog supercedes all previous ones.

- around the year

trainboard no more than 36" wide. Adapter track sections are available which will connect the M-Track to the K-Track.

A. C. Current Operates Everything

The trains, lights, turnouts, points, signals and all the other exciting accessories all operate off reliable A.C. current; never a need for two types of power supply. Even the TELEX coupling requires the same basic current only.

Every MÄRKLIN Locomotive Reverses by Remote Control

The same throttle knob that controls the speed of the train reverses the locomotive. Even small hands learn precise train control quickly. Our exclusive reverse unit, mounted in the locomotive, allows any train to be run over the entire track system, regardless of the wiring or the track configuration. This feature is especially useful when used with our automatic train control, running over changing routes.

The MÄRKLIN Overhead Catenary

Special clip-on mast and flexible contact wires allow an easily assembled, easily changed catenary system.

The locomotives with pantographs actually can pick up power from the overhead wires. A hand lever on the bottom of the locomotive changes the current pickup from the rails to the overhead wires. For maximum operation with your MÄRKLIN locomotive, the catenary wires can be connected to a separate transformer from the rails. This will allow

you to run two separate locomotives on the same section of track, completely independent of each other.

Locomotives have extra pulling power

All MÄRKLIN Locomotives, large and small, have special rubber tires and precision gearing to the drive wheels, for greater pulling power. Trains coast to a realistic stop when the power is turned off.

Track may be insulated at any point

Simply insert paper between the center tongues on M-Track, or the plastic insulator on K-Track. No other equipment or special pieces of track are needed.

The MÄRKLIN Couplers

The MÄRKLIN couplers mounted in the center of the ends of all equipment so that they can be placed on the track in either direction. All the different types of couplers will mate with each other.

The Automatic Couplers

Simply push the cars together and they are automatically coupled. Lift the end of the car and they are uncoupled, or use electric uncoupling track for a more realistic train operation. Its easy and fool-proof for fun operations.

RELEX, the automatic coupler with delayed uncoupling action

With this coupler, after the cars are uncoupled over the uncoupling track, the couplers remain open allowing you to push the cars farther down the track for more realistic yard switching. All model freight cars and passenger coaches are equipped with MÄRKLIN RELEX couplers.

The TELEX coupler, the ultimate system

Some locomotives (see pages 8, 10 and 20) are fitted with the TELEX couplers. This is operated from the transformer, through the reverse unit, allowing you to uncouple the locomotive from the train anywhere on the layout, without any other special equipment. The TELEX coupler system is another exclusive feature of MÄRKLIN trains.

MÄRKLIN Signals for added enjoyment

Our vast range of signals help you complete your model railroad. Our famous automatic multi-train control can be installed easily by nonexperts. Color coded wires plug into contact tracks, and the moving trains do the rest.

MÄRKLIN is easy to set up

Basic instructions with clear illustrations, printed in English, are provided with all equipment. Books include track plans, signal manuals and general handbooks.

Our No. I Gauge and MINEX Trains are described on pages 58—63.

Contents

Train Sets, Ready to Run				
	in Minex	58/59	in HO Scale	2-7
			in No. I Gauge	61/62
HO Locomotives	8-25		Steam	8-11
			Electric	12-18
			Diesel	20-23
			Electric Railtrains/Railbus	24/25
			HAMO Locomotives for 2 rail D. C.	8-25
			Pickup Shoes, Locomotive Tires, Bulbs	52/53
HO Rolling Stock			Passenger Cars	27-33
			Freight Cars	35-39
HO Construction Kits			Cars	40
			Interiors	31
Minex			Locomotives, Cars, Accessories	58-60
No. I Gauge			Locomotives, Cars, Accessories	61-63
Miniature Automobiles "rak"				65
MÄRKLIN-SPRINT Automobile Racing				66-71
Track	M-Track	41-43	K-Track	48/49
			No. I Gauge Track	63
Signals	for M-Track	44	for M- and K-Track for Minex	51 59
			Universal Remote Switch	44/51
Catenary System			for M-Track	45
			for K-Track	50/51
Transformers				57
Accessories	M = 47	K = 52	M + K =	52-54
	Other Locomotive Accessories			52/53
Interior Lighting	56	Electronic Warning Horn		54
Books			Handbooks	55
			Track Plans, Signal Manuals	55
			MÄRKLIN-Magazine	55
Metal Construction Sets / Electric Motors				72/73

GEBR. MÄRKLIN & CIE. ^{GM}_{BH} 732 GÖPPINGEN WÜRTT.

Trade Mark



All rights reserved · Reprints, even in extract, are forbidden · Printed in Germany · Mohndruck Gütersloh · 150 10 — RN 0671 mo

Train Sets with Oval Track and Reversing

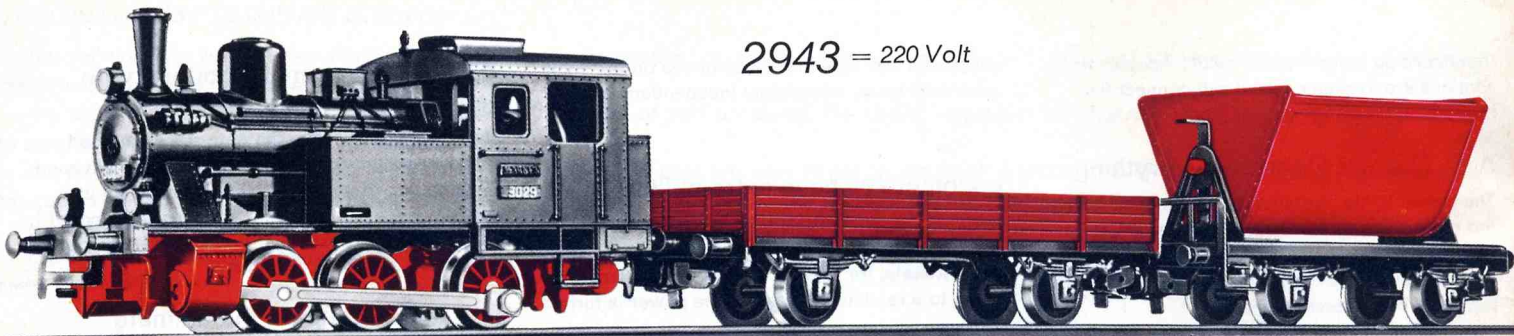

2943 = 220 Volt

2940 = 110 Volt

2941 = 125 Volt

2955 = 110 Volt for USA

2959 = 240 Volt for England

The transformer supplied with these Train Sets has, like all MÄRKLIN model railway transformers of the 6100 and 6500 Groups, connections for supplying current for trains as well as lighting and magnetically-operated accessories. It also supplies high-voltage current for reversing the locomotives. These transformers will also operate larger locomotives, or additional turnouts and signals. If overloaded or temperature should rise too high, the transformer will switch itself off automatically.



The transformers in these starter sets are not sold separately.

2940 - 2959 Freight Train with Transformer **M**-Track
 With locomotive, 2 freight cars, 8 curved track 5120, 1 straight track 5106, 1 feeder track 5111, and a transformer · Train 12" long

2960 - 2979 Freight Train with Transformer **M**-Track
 With 3000 locomotive, 2 freight cars, 12 curved track 5100, 1 straight track 5106, 1 feeder track 5111, and a transformer · Train 12½" long

These transformers must be used only with alternating current (A.C.)

2800 - 2819 Freight Train with Transformer **K**-Track
 With locomotive 3000, 2 freight cars, 12 curved track 2121, 1 straight track 2100, 1 feeder track 2190, 2 cables, and 1 transformer · Length of train 12½"

For enlarging Train Sets 2940 - 2959 and 2960 - 2979

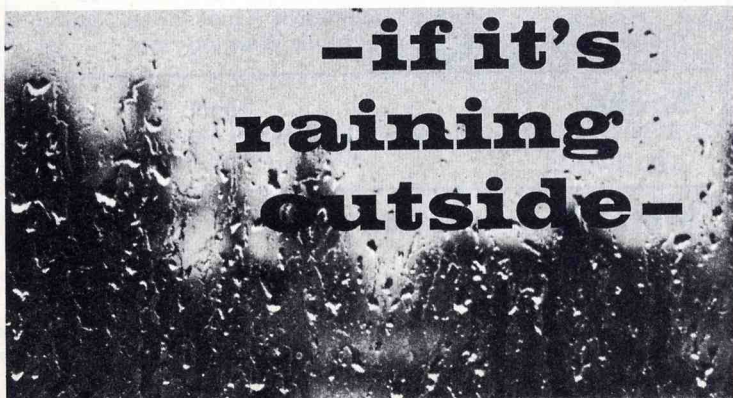

MÄRKLIN



Transformer to Operate Your Train and Accessories

For enlarging starter train sets we recommend supplementary items

M

2960 = 110 Volt

2961 = 125 Volt

2963 = 220 Volt

2975 = 110 Volt for USA

2979 = 240 Volt for England

2800 = 110 Volt

2801 = 125 Volt

2803 = 220 Volt

2815 = 110 Volt for USA

2819 = 240 Volt for England

M

K



Train Sets to start your railway system

These train sets, supplied in a sturdy gift box, designed to safely store the train, provide the beginning of a model railroad layout. Naturally, there is more fun and enjoyment when your passenger and freight trains can make longer trips, and the cars can be switched in the yards. The track addition sets shown on, pages 47 and 49 show how easy it is to extend your basic set for more enjoyment. The layouts take a minimum of space and can be quickly assembled and taken apart. The track can be stored back in the box when you are through.

we recommend the supplementary track sets 5090, 5091 and 5092 on page 47 and for the Train Sets 2800 - 2819 we recommend the supplementary track sets 2090 and 2091 on page 49.



MÄRKLIN

Attractive Gift Boxes

Train Sets

*without transformers
with oval track*

3200

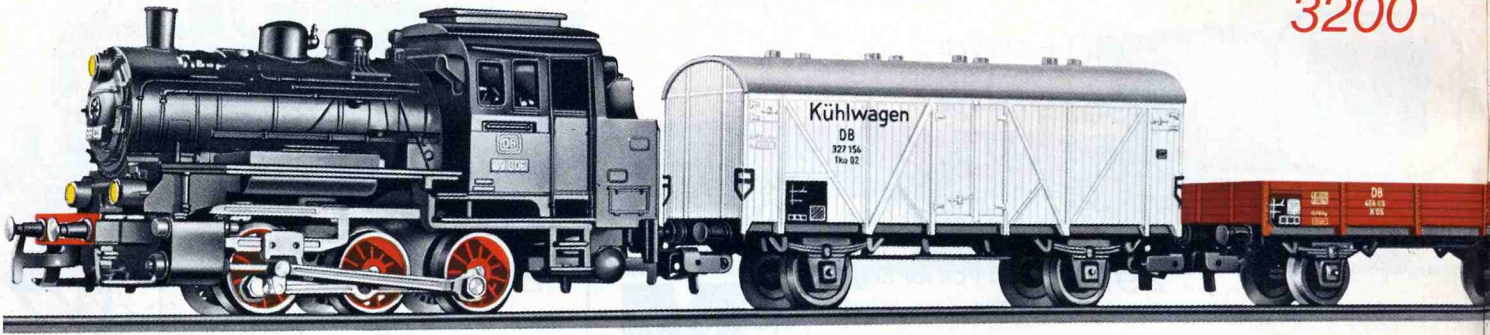

3200 Freight Train (without transformer)

Consisting of locomotive 3000 and three freight cars · Twelve 5100 curved and two 5106 straight track sections, including feeder section · Train about 16¾ in. long

M -Track

that can be expanded

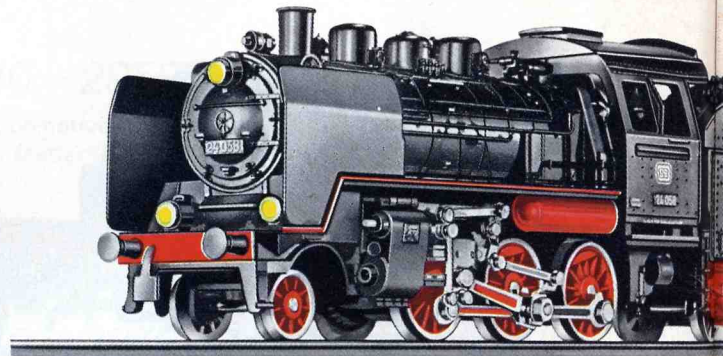

For enlarging

*Use with alternating
current (A.C.) only*

**-in case of snow, mud and
cold-**

MÄRKLIN





Attractive Gift Boxes

These larger train sets in sturdy gift boxes are a fascinating gift for a model railroad fan.

We supply the larger train sets with a track oval but without transformers as they are bought as gifts to extend the beginners layout, and also because many people prefer to start with the larger transformer which will be necessary for the larger model railroad (see page 57).

For enlarging these train sets 3200, 3203 and 3183 we recommend the supplementary track sets 5090, 5091 and 5092 on page 47 and the track sets 2090 and 2091 on page 49. You will have more fun with a larger layout.

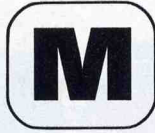
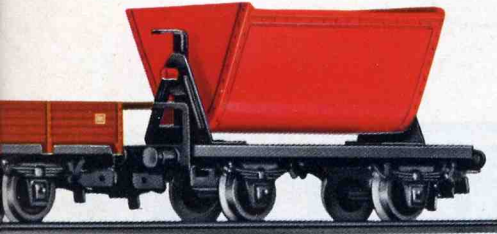

train sets
3200 and 3203
we recommend
the supplementary
track sets 5090,
5091 and 5092
on page 47
and for the train 3183,
the supplementary track sets
2090 and 2091 on page 49.

3203

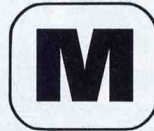

3183



3203 Freight Train (without transformer) **M**-Track

Consisting of locomotive 3003, three freight cars, twelve 5100 curved and two 5106 straight track sections, including feeder section · Train about 21 in. long

3183 Freight Train (without transformer) **K**-Track

Steam Locomotive 3003, 3 freight cars, 12 curved track 2121, 1 straight track 2100, 1 feeder track 2190, 2 feeder cables · Train about 21 in. long

new



MÄRKLIN

Attractive Gift Boxes

Train Sets with oval track but without transformer,

3121



For enlarging train set

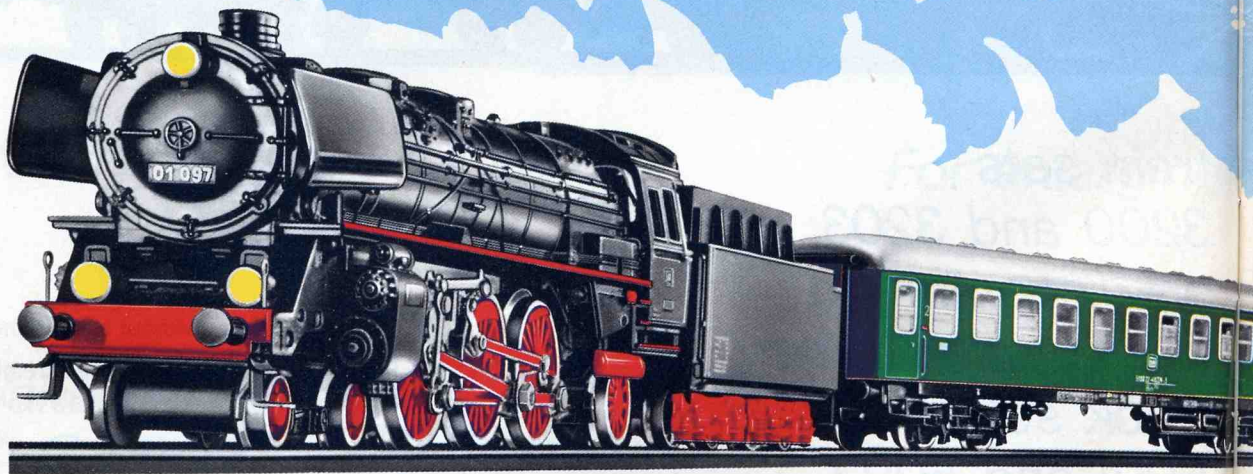

3188



**...if a weekend
is spoiled
by rain -**

MÄRKLIN



that can be extended

3121 Passenger Train (without transformer)

M-Track

With diesel locomotive 3021, passenger coach, restaurant car, and baggage car, 12 curved track 5100, 6 straight track 5106, including feeder track · Train 38½ in. long



3121 we recommend the supplementary track

sets 5090, 5091 and 5092

on page 47.

3188 Passenger Train with Turnouts (without transformer)

With express locomotive 3048 with smoke unit, 2 passenger coaches, 1 restaurant car, 1 baggage car, 14 straight track 2100, 4 straight track 2107, 10 curved track 2131, 2 curved track 2132, 2 curved track 2134, 1 pair of remote control turnouts 2161, 1 feeder track 2190, 1 control panel 7072, 6 connecting cables · Train 50 in. long



K-Track

Use with alternating current (A. C.) only



3029

Tank Locomotives

3000

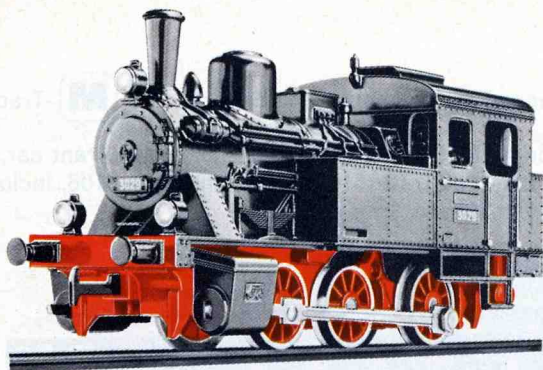

3029 TANK SWITCHER · A model of a six-wheeled 0-6-0 locomotive as used in large industrial concerns · Remote control reversing and fitted with two special rubber tires to increase pulling power · Dull black plastic with a cast metal frame · Coupling hooks both ends · 4 in. long over buffers

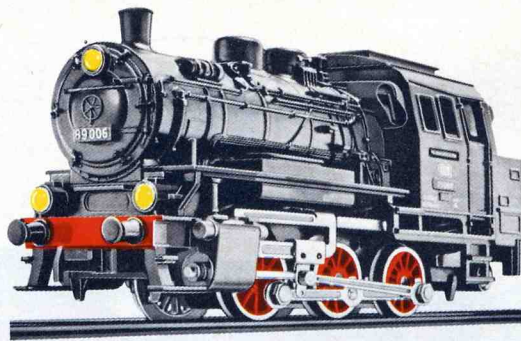

3000 TANK LOCOMOTIVE · A model of the six-wheeled 0-6-0 Class 89 engine · Reversing by remote control · Two special rubber tires on the rear drivers to increase pulling power · Three working headlights · Die cast metal frame · Coupling hooks both ends · 4³/₈ in. long over buffers

Tank locomotives (They carry their coal and water "piggy back") are for switching and for short passenger and freight train runs. These beautiful models are favorites—easy to put on the track, to stay on the curves at high speeds, to pull long trains of shorter cars.

Tender Locomotive with MÄRKLIN-TELEX Couplers

3031



THE MÄRKLIN-TELEX-COUPLING

enables the train to be uncoupled from the engine and also coupled up to it again at any desired point on the system, by remote control from the transformer, without any additional accessories being necessary.

3031 TANK LOCOMOTIVE · A model of the eight-wheeled 0-8-0 Class 81 engine on the German Federal Railways · Two rubber tires to increase pulling power · Simulated Walschaerts valve motion, and reversing by remote control · Three working headlights at each end · Cast metal frame with all-metal body finished in dull black · MÄRKLIN-TELEX-COUPLING at both ends · 5 in. long over buffers

3096

new

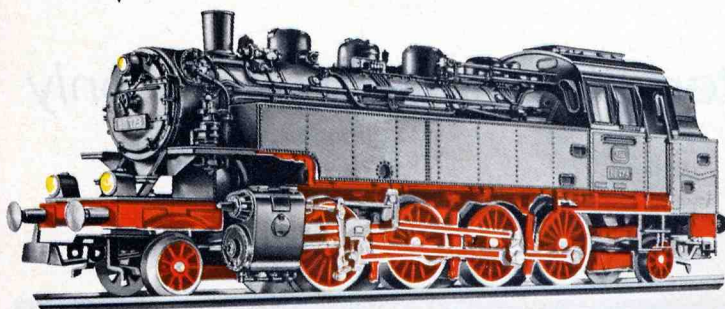

**German Railways
"BR 86" Tank Locomotive
with TELEX-Coupling**

The former German Railways, "Deutsche Reichsbahn," used 774 locomotives of the Class 86 type for freight and passenger service on secondary lines. After the war the German Federal Railways kept 385 of these locomotives in operation. A small quantity of the Class 86 is still in use today in Germany. Some of the prototype locomotives were equipped with Krauss-Helmholtz frames which increased the speed about 10%. The length of the prototype is 45'6" and weighs approximately 80 tons.

3096 TANK LOCOMOTIVE · A model of the Class 86 2-8-2 locomotive of the German Federal Railways · Rear drivers have rubber tires to increase the pulling power · Heusinger valve gear · Remote control reversing · Three working headlights on the front and rear · Fully detailed plastic body finished in dull black · Die cast metal underframe · MÄRKLIN-TELEX-COUPLING on each end · 6¹/₄" in length

**... and
when the sun
is shining
bright -**

HAMO

8396

The same model as 3096, but for two rail, D.C. operation (also see page 12) but **without TELEX-Coupling**

MÄRKLIN



3003

Mixed Traffic Steam Locomotive

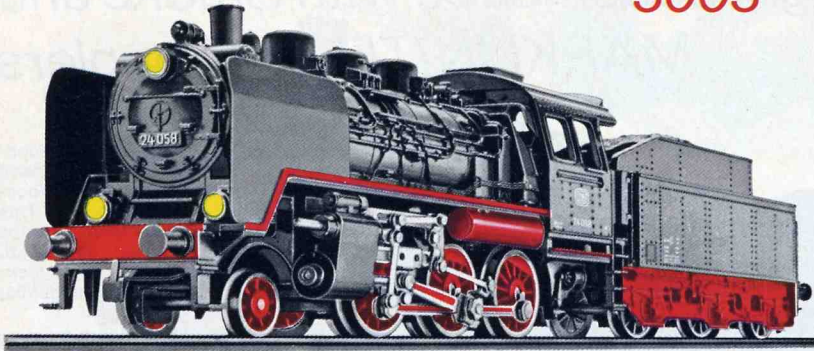

The standard Class 24 locomotive was used on the German Federal Railways for passenger and goods services, its maximum speed being 56 miles an hour.

3003 PASSENGER LOCOMOTIVE WITH TENDER · A model of the eight-wheeled 2-6-0 Class 24 engine on the German Federal Railways · Reversing by remote control and with simulated Walschaerts valve motion · The leading truck is kept down on the track by a spring so there is no risk of derailment · Two special rubber tires to increase pulling power · Three working headlights · Dull black plastic body on die cast metal frame · Tender close-coupled to the engine, with all details of the six-wheeled riveted construction reproduced · Coupling hook in front with RELEX automatic coupling with the Advance uncoupler on the tender · 8 in. long over buffers

3095

"BR 74" An Unusual Tank Locomotive by MÄRKLIN

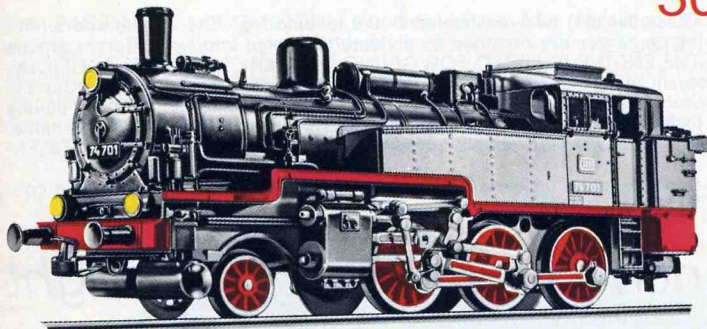

The superheated steam engines first delivered in 1902 as the T 12 locomotive to the Berlin State Railways' Directorate, and subsequently given the Class 74 description when taken over by the then German State Railways (Deutsche Reichsbahn), proved so very successful for suburban passenger services, especially on the Berlin Circle, Metropolitan and suburban lines that there were nearly one thousand of them in service by 1921. After electrification of the Berlin Metropolitan Line they were allotted to numerous centers for use on shortdistance passenger services, as well as on switching work at large stations. Their length over buffers was either 38 ft. 8 in., or 39 ft. 8 in. according to their series. Weighing approximately 70 tons in working order they could reach a speed of 50 miles an hour running either forward or tender first.

3095 TANK LOCOMOTIVE · A model of the German Federal Railways' eight-wheeled 2-6-0 Class 74 engine · Fitted with two special rubber tires to increase pulling power and simulated Walschaerts valve motion · Reversing is by remote control · The leading truck is kept down on to the track by a spring to safeguard against derailment · Three working headlights · Plastic body with die cast metal frame · Coupling hook in front with Advance uncoupler, RELEX Coupling at rear · 5 1/4 in. long over buffers

Available again
3005

Modern Steam Locomotive

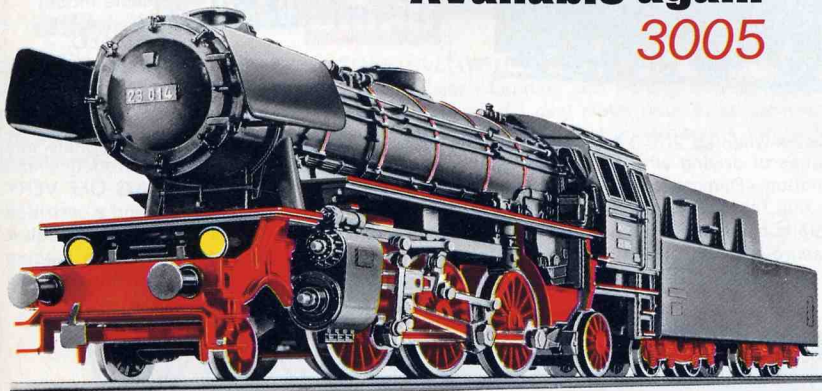

The German Federal Railways Class 23 locomotives are used for medium and heavy passenger service and for fast express freight service. Because of the construction of this class of locomotive, they can be operated at speeds of up to 70 mph forward and 55 mph when running tender first. Because of the high speed permitted while running backwards, these locomotives are used to a great extent in local service on heavy freight trains. This helps give the railroads a much better balance in the dispatching of the locomotives.

3005 LOCOMOTIVE WITH TENDER · A model of the German Federal Railways Class 023 (23) · Prairie type 2-6-2 wheel arrangement · Remote Control reversing · Heusinger valve gear · Leading and trailing trucks are sprung to prevent derailing · Two rubber tires to increase the pulling power · Two working headlights in front · Dull Black all metal body · Die cast metal frame · Eight-wheel tender, closely coupled to the locomotive · Automatic coupling with the RELEX Advance uncoupler at both ends · Length over buffers 9 3/4"



3047

Heavy Freight Locomotive with Smoke and MÄRKLIN-TELEX-Couplers

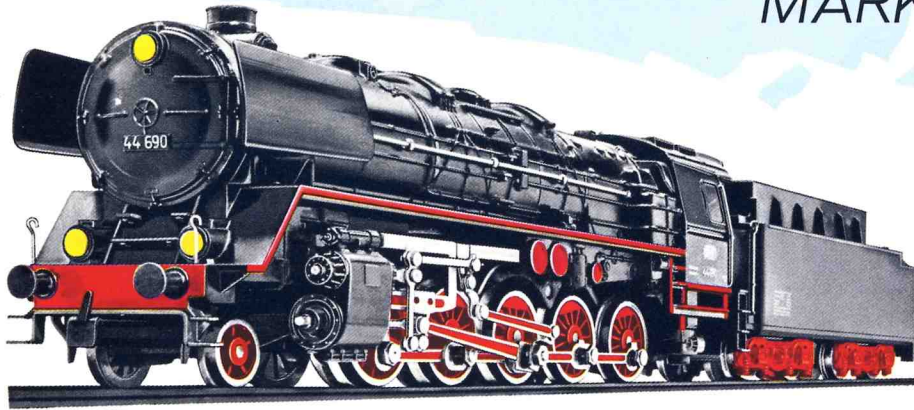

This is one of the most powerful steam locomotives in freight service on the German Federal Railways. The prototype Series 044 (44) locomotive develops almost 2000 horsepower. This magnificent machine is seen on long distance runs in areas which are not yet electrified. Because of the imposing look of this locomotive we have been very careful in modelling this piece of equipment.

The same model as 3047, but for two rail, D.C. operation,

HAMO 8347

(also see page 12)

3047 HEAVY FREIGHT LOCOMOTIVE · A model of the German Federal Railways' Class 044 (44) twelve-wheeled 2-10-0 locomotive · The engine and tender are permanently coupled together · Excellent running characteristics and easy running on curves are obtained by dividing the frame into two different groups of driving wheels · Remote control reversing · Simulated Walschaerts valve motion · THE ENGINE IS FITTED FOR GIVING OFF VERY REALISTIC ARTIFICIAL SMOKE, the equipment consisting of the smoke unit fitted in the engine, substitute steam pipe, cleaning wire, tweezers and cartridge of steam fluid (for the 0241 refill cartridge see page 53) · The spring suspension of the leading pony truck ensures safety against derailment · Four rubber tires to increase the pulling power · Three working headlights · Dull black die cast metal body · Coupling hook fixed to leading truck provides full front coupling facilities · Scale model SMOKE DEFLECTOR PLATES · Cab windows with frosted plastic panes · Die cast metal frame · Eight-wheeled double-bogie tender fitted with the MÄRKLIN-TELEX-COUPLING · 11 in. long over buffers
The MÄRKLIN TELEX coupling fitted in the tender enables the train to be uncoupled at any point on the system, and also coupled up again, by remote control from the transformer without requiring any extra equipment.

3046

French Railways Steam Freight Locomotive with Smoke Unit



HAMO 8346

The same model as 3046, but for two rail, D.C. operation, (also see page 12)

3046 HEAVY FREIGHT LOCOMOTIVE · A model of the Class 150 X twelve-wheeled 2-10-0 locomotive of the French State Railways (Société Nationale des Chemins de Fer Français, or S.N.C.F.) · Dividing the frame into two groups of driving wheels, linked together, gives very good running characteristics and enables the engine to take curves well · Simulated Walschaerts valve motion · Remote control reversing · THE ENGINE IS FITTED FOR GIVING OFF VERY REALISTIC ARTIFICIAL SMOKE, the equipment consisting of the smoke unit fitted in the engine, substitute steam pipe, cleaning wire, tweezers and a cartridge of steam fluid (for 0241 refill cartridge see page 53) · The spring suspensions of the leading pony truck ensures safety against derailment · Four special rubber tires on the trailing drivers increase the pulling · Two headlamps · Pressure-cast zinc frame with body finished in dark green · Coupling hook on leading pony truck gives full coupling facilities in front as well · Cab windows are glazed · The eight-wheeled double bogie tender has an automatic coupling with the RELEX Advance uncoupler · 11 in. long over buffers

The Classic "P 8" Locomotive by MÄRKLIN

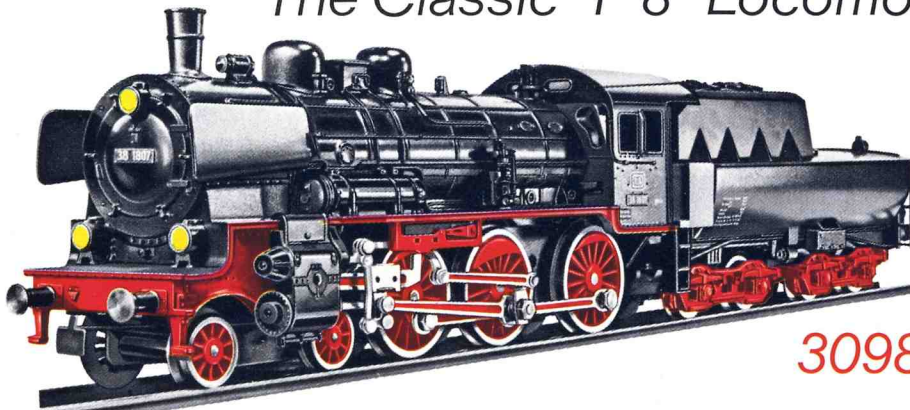

3098

HAMO 8398

The same model as 3098, but for two rail D.C. operation, (also see page 12)

3098 STEAM LOCOMOTIVE WITH TENDER · A model of the German Federal Railways' ten wheeler, 4-6-0 Class 038 (38) locomotive · Remote control reversing · Heusinger valve gear · Special springing prevents lead truck from derailing · Two rubber tires on rear drivers to increase the pulling power · Three working headlights · Flat black all metal body with all boiler and cab details finely reproduced · Die cast metal frame · Eight-wheeled tender with automatic Advance (RELEX) couplers · 9 1/2 in. long over buffers



Steam Passenger Locomotive with Smoke

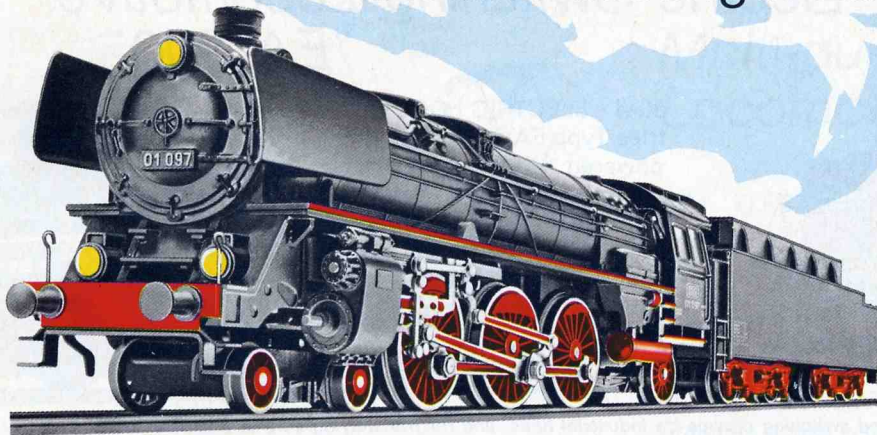

3048

This passenger locomotive of Series 001 (01) is among the handsomest and most powerful in service on the German Federal Railways at the present time.

3048 PASSENGER LOCOMOTIVE · A model of the 4-6-2 Passenger locomotive Class 001 (01) of the German Federal Railways · Remote control reversing · Walshaerts valve gear · LOCOMOTIVE PRODUCES VERY REALISTIC SMOKE, the equipment consisting of the smoke unit, replacement steam pipe, cleaning wire, tweezers and smoke capsule (for refill see 0241 smoke fluid on page 53) · Special springing prevents leading and trailing trucks from derailing · Two special rubber tires on rear drivers to increase pulling power · Three working headlights · Black, all metal body · Die cast metal frame · Two truck tender with automatic Advance coupler (RELEX) · 11 in. long over buffers

3094

Streamlined Steam Locomotive "03¹⁰"

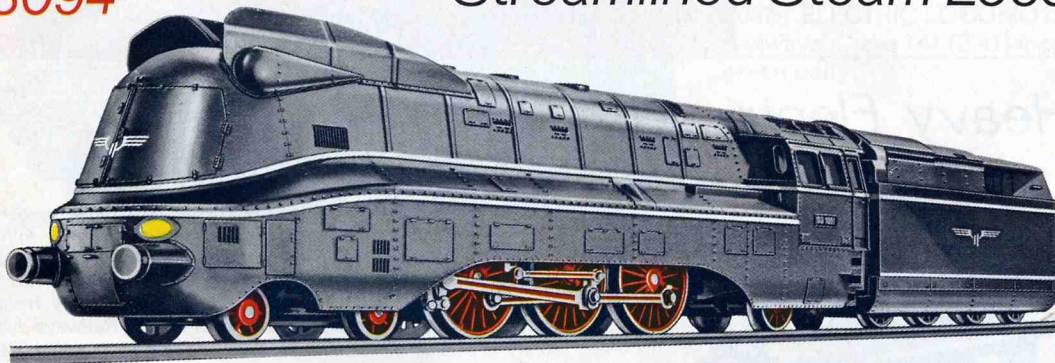

After streamlined fairings had proven themselves in other locomotives because of the reduction of wind resistance at high speeds, the Class 03¹⁰ locomotives were put into service with streamlined bodies in 1937. However, to make the maintenance of the frame easier the drivers were left uncovered. It was developed as a lighter version of the Class 01 locomotive with an original 17 tons per axle load and a top speed of 84 mph.

3094 STREAMLINED EXPRESS LOCOMOTIVE WITH TENDER · Model of the German Federal Railways' Class 03¹⁰ · 4-6-2 Wheel arrangement, Pacific type · Remote control reversing · Heusinger valve gear · Leading and trailing truck are sprung to prevent derailments · Rear drivers have rubber tires to increase pulling power · Two working headlights · Dull black die cast metal body in streamlined shape with silver stripes · Fully detailed cab and boiler backhead features · Windows have frosted plastic panes · Die-cast metal underframe · Tender has two 4 wheeled trucks and delayed action automatic couplers (RELEX) · Length over buffers 10³/₄"

new

3089

"03¹⁰"

– Dark Red Finish –



3089 STREAMLINED EXPRESS LOCOMOTIVE with tender · Identical to model 3094, but with die-cast metal body in streamlined shape with silver stripes · Black smoke deflector plates

MÄRKLIN
pleasure throughout
the year –

3044



*Electric Switching Locomotive
"EA 800"*

3044 ELECTRIC LOCOMOTIVE · Model of the Mehrsystem Industries Type EA 800 industrial locomotive · Six-wheeled with all axles powered · Two rubber tires to increase pulling power · Remote control reversing · Three working headlights on the front · Red plastic body with silver stripes · Single bar pantograph mounted on roof · Clear plastic windows · Metal die cast frame, painted grey, with finely detailed journal boxes · Coupling hooks at both ends · Length 4 1/2" over buffers

Locomotives of this type are designed both for road and switching service on industrial lines, and for transferring cars to mainline railroads. They can draw power both from overhead power lines or from internal batteries. Maximum speed is approx. 35 mph. The locomotive with single axle drive develops 39,000 lbs. tractive effort. It weighs 60 tons and measures 32 feet in length.

HAMO

HAMO Locomotives for two rail D.C. are equipped with permanent magnet motors and can be reversed by changing the polarity of the current. Electric locomotives have headlights on each end that change when you change the direction of the locomotive. These models will run on all tracks complying with NEM standards. A set of interchange couplings is supplied with each locomotive, allowing other makes of rolling stock to be coupled to it.

HAMO

HAMO - Locomotives are a product of MÄRKLIN

"194" (E 94) Heavy Electric Freight Locomotive

3022



The 194 (E 94) locomotive is the workhorse of the railroads. They have six traction motors with a total of 6350 horsepower, and a service weight of 120 tons. They have a maximum speed of 56 mph and are used mainly for heavy freight operations. The German Federal Railways have 124 of these impressive looking locomotives now in service.

HAMO 8322

The same model as 3022, but for two rail D.C. operation (see above)

3022 ELECTRIC FREIGHT LOCOMOTIVE · A model of the twelve-wheeled 0-6-6-0 (Co-Co) Class 194 (E 94) locomotive on the German Federal Railways · Three axles are driven and there are four special rubber tires to increase the pulling power · Reversing is by remote control · The model has three working headlights, front and rear · Selector lever for optional working from either the overhead contact wire or surface contact · Two spring-loaded pantographs on roof · Inset windows with plastic frames · Automatic coupling with the RELEX Advance uncoupler at both ends · 8 1/4 in. long over buffers

**A fascinating
hobby -
A great way to
relax -**

MÄRKLIN



3034



"141" (E 41)
Multi-purpose Electric Locomotive

3034 ELECTRIC LOCOMOTIVE · A model of the German Federal Railways' eight-wheeled 0-4-4-0 (Bo-Bo) Class 141 (E 41) locomotive · Both axles of the trailing bogie are driven · There are four special rubber tires to increase pulling power · Reversing by remote control · Three working headlights, front and rear · Selector lever for optional working from either the overhead contact wire or surface contact · Two spring loaded pantographs on roof · Blue all-metal body with silver roof and fixed buffer beams · Coupling hooks with the Advance uncoupler both ends · 7 in. long over buffers

3037



The in service weight of the 141 (E 41) locomotive is 66.4 tons and is 50 feet in length. Its four traction motors exert 3100 horsepower with a maximum speed of 75 mph. These locomotives are used for both fast passenger and freight service and are seen finished in either blue or green.

3037 ELECTRIC LOCOMOTIVE · A model of the German Federal Railways' Class 141 (E 41) locomotive · Similar to No. 3034 but with green body

Replacement parts for MÄRKLIN-HO Locomotives

see pages 52/53

- | | |
|----------------------|-----------------|
| Rubber Tires | Pantographs |
| Current Pickup Shoes | Motor Brushes |
| Bulbs | Lubricating Oil |
| Reverse Unit Springs | Smoke Fluid |



3039



"110" (E 10) Electric Express Locomotive

3039 ELECTRIC EXPRESS LOCOMOTIVE · A model of the two truck 110 (E 10) locomotive of the German Federal Railways · Four wheel drive with rubber tires to increase the pulling power · Remote control reversing · Three working headlights at each end · Selector lever to pickup current from the overhead wires or track stud contacts · Blue all metal body with solid buffers · Scale reproduction of all roof details, with two scale pantographs · Windows inset in plastic frames · Automatic Advance coupler at each end · 7 1/8 in. long over buffers

The Series E 10 and E 40 electric locomotives which are now designated as 110 and 140 for use with the German Federal Railways, were purchased in 1956. In outward appearance the only difference is the color, but their duties and power are entirely different. The 110 (E 10) is used as a passenger locomotive with a maximum speed of 90 mph, while the 140 (E 40) is used for freight service with a top speed of 60 mph. Both locomotives, however, have a horsepower rating of 5000 and transmit their power to the axles through a standard differential, but different transmission. These locomotives measure almost 50 feet in length and when ready for service have a weight of 85 tons. In addition to use in Germany, several of the 140 (E 40) locomotives were loaned temporarily to Switzerland, where they gave excellent service.

"140" (E 40) Freight Locomotive of the German Federal Railways

3040



3040 ELECTRIC FREIGHT LOCOMOTIVE · A model of the two truck 140 (E 40) locomotive of the German Federal Railways · Four wheel drive with rubber tires to increase the pulling power · Remote control reversing · Three working headlights at each end · Selector lever to pickup current from the overhead wires or track stud contacts · Green, all metal body with solid buffers · Scale reproduction of all roof details, with two scale pantographs · Finely finished lettering · Windows inset in plastic frames · Automatic Advance coupler at each end · 7 1/8 in. long over buffers

The "103" (E 03) –

Latest Version of DB

3054



HAMO 8354

The same model as 3054 but for two rail D.C. operation (also see page 12)

– for children and adults –

MÄRKLIN



Italian Electric Locomotive

3035

3035 ELECTRIC LOCOMOTIVE · A model of the Italian State Railways' eight-wheeled 0-4-4-0 (Bo-Bo) Class E 424 locomotive · Two axles are driven with four rubber tires to increase the pulling power · Reversing by remote control · Two working headlights front and rear · Selector lever for optional working from either the overhead contact wire or surface contact · Two spring-loaded pantographs on roof; all-metal body with fixed buffer beams and windows glazed with cellophane · Coupling hooks with the Advance uncoupler both ends · 6⁷/₈ in. long over buffers

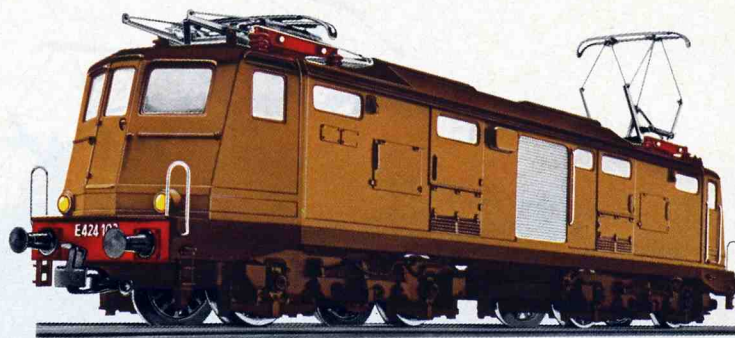

Austrian Electric Locomotive

3036

The full-sized original of this MÄRKLIN model is in service on the Austrian Federal Railways chiefly on routes where conditions are favorable as regards gradients and directions. These locomotives weigh 80 tons, each and have a one-hour rating of 3400 H.P., their maximum speed being about 70 miles an hour.

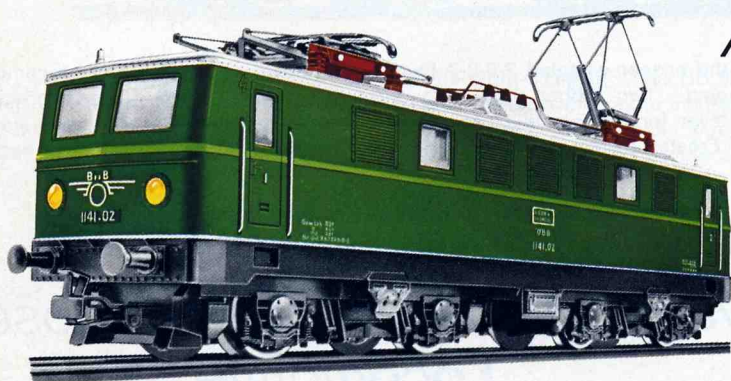

3036 ELECTRIC LOCOMOTIVE · A model of the Austrian State Railways' eight-wheeled 0-4-4-0 (Bo-Bo) Class 1141 locomotive · With four rubber tires to increase the pulling power · Remote control reversing · Two working headlights front and rear · Selector lever for optional working from either the overhead contact wire or surface contact · Two spring-loaded pantographs on roof · Allmetal body with fixed buffer beams · Frosted plastic windows · Coupling hooks with the Advance uncoupler both ends · 6⁷/₈ in. long over buffers

the Fastest, Most Powerful Locomotive

3054 ELECTRIC EXPRESS PASSENGER LOCOMOTIVE · A model of the 103 (E 03) Class locomotive of the German Federal Railways · Two six wheel trucks · Three axles powered · Four rubber tires to increase the pulling power · Remote control reversing · Three working headlights at each end · Working roof lights as on the prototype · Selector lever for picking up power from the center rail or from the overhead wires · The locomotive frame, which extends to the red stripe above the lower headlights, is of die cast metal · Special low center of gravity · Plastic body finished in the correct red/beige TEE colors · The body is of the latest prototype version with two rows of side vents and no rain gutters · Clear plastic windows inset in individual frames · Two working pantographs on roof · Aluminium color roof · Simulated compressed air, quick release switch · Coupler hooks at each end · Length over buffers 8¹/₂"

These are the fastest, most powerful electric express locomotives in service of the German Federal Railways and they have the most elegant aero-dynamic design. Six traction motors, one of each axle, produce 9000 horsepower and a rated speed of 125 mph. They are 62 feet in length with a weight of 112 tons. All the splendid features of the original are captured in this exquisite MÄRKLIN model.



Swiss Heavy Freight Electric Locomotive
 "Crocodile"

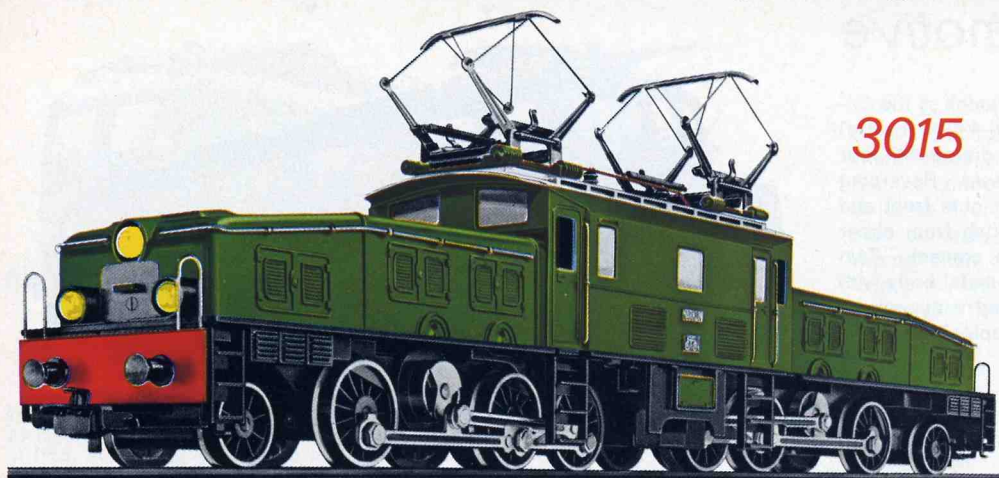

3015

This giant 16 wheeled electric Swiss locomotive Be 6/8, nicknamed "The Crocodile", is the real "King of the Mountains". It is undoubtedly the most impressive locomotive of the Swiss Railways. It is with particular pleasure that we have modeled this prototype with the greatest care in HO scale.

3015 ELECTRIC FREIGHT LOCOMOTIVE — the "Crocodile" · A model of the sixteen-wheeled 2-6-6-2 Swiss locomotive · This articulated locomotive is able to negotiate the regular curves with ease · Remote control reversing · Two rubber tires to increase the pulling power · Three working headlights that change code as the locomotive changes direction · Selector lever for picking up current from the overhead wires or the track stud contacts · Two working pantographs on the roof · Green, all metal body · Frosted plastic windows · Automatic Advance couplers (RELEX) at each end · 10 1/4" long over buffers

3050

The Swiss Federal Railways' Powerful Multi-purpose Locomotive



The Swiss Railways ordered the Ae 6/6 for international passenger runs and for fast freight service. The locomotives weight of 120 tons with 6000 horsepower in its six motors, give it an enormous starting effort and climbing power. Maximum speed is 80 miles per hour. With all its giant power, it still has a particularly handsome appearance, and this was sufficient reason for us to model it most accurately.

3050 ELECTRIC ALL PURPOSE LOCOMOTIVE · A model of the twelve-wheeled Series Ae 6/6 locomotive of the Swiss Federal Railways · Six wheel drive with four special rubber tires to increase the pulling power · Remote control reversing · Three working headlights at each end · Selector lever for picking up power from the overhead wires from the tracks stud contacts · Two working pantographs on the silver roof · Green die cast metal body with solid buffers · Scale details of the locomotive of the "Bern Kanton" · Frosted plastic windows · Coupler hooks at each end · 7 7/8" long over buffers · Crests of the other Swiss Cantons are supplied with this locomotive

**-for your
leisure time-**

MÄRKLIN



French Heavy Electric Locomotive

3038



The prototype of our model 3038 is used for both freight and passenger service on the French National Railways. Its four motors develop a total of 5500 hp and gives the locomotive a maximum speed of 100 mph, weight 80 tons.

3038 ELECTRIC LOCOMOTIVE · A model of the eight-wheeled Class BB 9200 locomotive of the French Railways (Société Nationale des Chemins de Fer Français, or S.N.C.F.) four wheel drive with four rubber tires to increase the pulling power · Remote control reversing · Two working headlights front and rear · Selector lever for picking up power from the overhead wires or from the track stud contacts · Two working pantographs on the roof · Turquoise all metal body, with frosted plastic windows · Automatic couplers at each end · 7 in. long over buffers

"Le Capitole" of the French Railways

3059



The Class 9200 locomotive used for hauling the French high-speed train. "Le Capitole" has a different gear ratio to the same locomotive of the standard series, and so can attain a higher speed. A train weighing 400 tons can be hauled by this locomotive at a speed of approximately 124 miles an hour.

HAMO 8359

The same model as 3059, but for two, D.C. operation, (also see page 12)

3059 ELECTRIC LOCOMOTIVE · A model of the S.N.C.F. eight-wheeled 0-4-4-0 (Bo'Bo') Class BB 9200 · Two axles are driven and four rubber tires to increase pulling power · Reversing is by remote control · Two working headlights, front and rear · A selector lever is fitted for optional working from either the overhead contact wire or surface contact · Two single arm pantographs · Red all-metal body with windows glazed with cellophane · Coupling hooks with the Advance uncoupler at both ends · 7 in. long over buffers



Swedish Electric Locomotive



3030

3030 SWEDISH ELECTRIC LOCOMOTIVE · Electric Locomotive for all service · A model of the Swedish State Railways Class Da locomotive · 2-6-2 wheel arrangement driven by geared jackshaft · Special springing prevents leading and trailing trucks from derailing · Two rubber tires on the drivers for increased pulling power · Three working headlights on each end · Selector lever for current pickup from the overhead contact wires or the track stud contacts · Two scale pantographs on the roof · Brown all metal body with solid buffers · Die cast metal frame · Automatic Advance couplers (RELEX) at each end · 5⁷/₈" long over buffers

The Da type locomotive is used by the Swedish Railways (Statens Järnvägar) for both freight and passenger service. Because these locomotives have only one motor and are relatively light, 15 tons, they are equipped with side rods driven from a jackshaft. This prevents skipping of individual wheels when the locomotive is starting.

Swedish Freight and Passenger Locomotive



3043

3043 MIXED TRAFFIC ELECTRIC LOCOMOTIVE · A model of the eight-wheeled class Rc Locomotive of the Swedish State Railways (Statens Järnvägar) · Four wheel drive with four rubber tires to increase the pulling power · Remote control reversing · Four working headlights at each end · Selector lever for picking up power from the overhead wires or track stud contacts · Orange plastic body with glazed windows inset in frames · Two spring loaded pantographs on roof · Die cast metal frame · Coupler hooks at each end · 6⁷/₈" long over buffers

The Swedish State Railways plan to have 60 of these locomotives in service. The A.C. power taken from the overhead wires on the prototype, is converted to D.C. in the locomotive to provide power for the four traction motors, delivering a total of 5000 h.p. These locomotives, weighing 76 tons, attain a top speed of 84 mph. The total length over the buffers is 51 ft. 9 in.

Netherland Railways Electric Locomotive



3051

3051 ELECTRIC LOCOMOTIVE · A model of twelve-wheeled 0-6-6-0 (Co-Co) 1200 Series locomotive on the Netherlands Railways (Nederlandse Spoorwegen, or N.S.) · Three axles are driven and four rubber tires to increase the pulling power · Reversing is by remote control · Three working headlights, front and rear · Selector lever for optional working from either the overhead contact wire or surface contact · Blue all-metal body with fixed buffer beams and two spring-loaded pantographs on silver roof · Inset windows with plastic frames · Coupling hooks at both ends · 7³/₄" long over buffers

The Netherlands Railways ordered altogether 25 of these 1200 Series locomotive built to American design for heavy mixed traffic. At a speed of approximately 45 miles an hour the six traction motors develop a total of 3000 H.P. The maximum speed is 84¹/₂ miles an hour and the locomotives are 59 ft. long. This locomotive with a few modifications, was also used by the New Haven Railway in the United States.

**- for
leisure time -**

MÄRKLIN

MÄRKLIN Layout Scale H0



MÄRKLIN ...a year round hobby!



**"260" (V 60) Diesel Hydraulic Switching Locomotive
with MÄRKLIN-TELEX-Coupling**



3065

3065 DIESEL LOCOMOTIVE · A model of the six-wheeled 0-6-0 (C) Class 260 (V 60) locomotive on the German Federal Railways · The three axles are driven and reversing is by remote control · Two special rubber tires to increase the pulling power · Three working headlights, front and rear, exactly the same as on the full-sized original · Red plastic body with numerous details and inset windows with plastic frames · Die cast metal frame · MÄRKLIN TELEX COUPLING at both ends · 4³/₄" long over buffers

TELEX see page 8

3064 with Standard Couplers

3064 DIESEL LOCOMOTIVE · A model of the German Federal Railways Class 260 (V 60) · Similar to the 3065 but with advance couplers at each end, NOT TELEX COUPLERS

The "DHG 500" Diesel Hydraulic Locomotive

3078 DIESEL LOCOMOTIVE · A model of a six-wheeled 0-6-0 (C) industrial locomotive known as the DHG 500 type · All axles are driven, with two special rubber tires to increase pulling power · Remote control reversing · Three working headlights, front and rear · Blue plastic body with two silver decorative bands · Die cast metal frame · Side frames with scale reproductions of the axles boxes · Strong coupling hooks at both ends · 4²/₄" long over buffers

3078

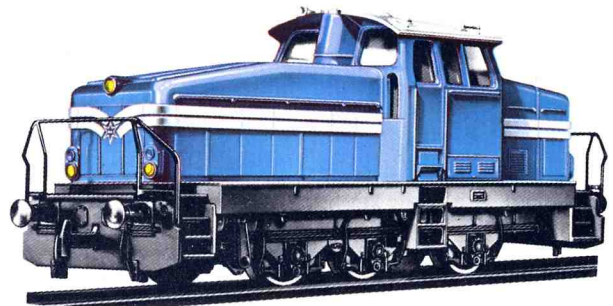

The prototype of these small diesel locomotives, with hydraulic transmissions, are approximately 40 feet long and yet pack many hundred horsepower under the hood. The locomotives are equipped with heavy duty transmissions which allow them to be used for long periods of time without service. These industrial locomotives (MÄRKLIN models 3078, 3080) are designed with windows at the bottom of the engineers cab which allows direct vision to the buffers for accurate switching.

Industrial Locomotive

3080



3080 DIESEL LOCOMOTIVE · A model of a six-wheeled 0-6-0 (C) Works locomotive · All axles are driven and there are two special rubber tires to increase pulling power · Remote control reversing · Yellow plastic body with two dark decorative bands; pressure-cast frame · Strong coupling hooks at both ends · 4²/₄ in. long over buffers

**-when
it's
raining-**

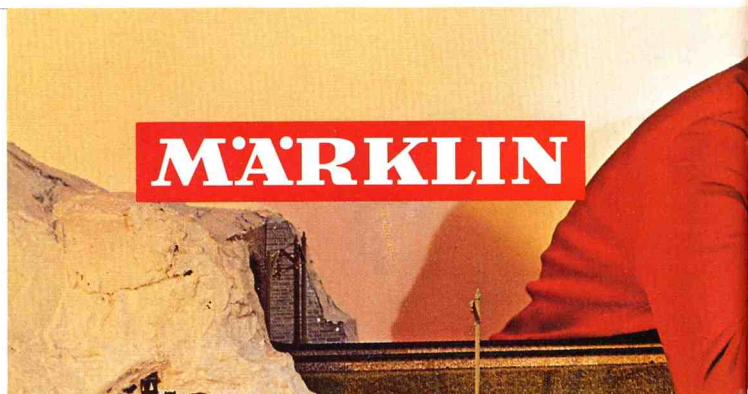

MÄRKLIN



Diesel Hydraulic Locomotive "212" (V 100)

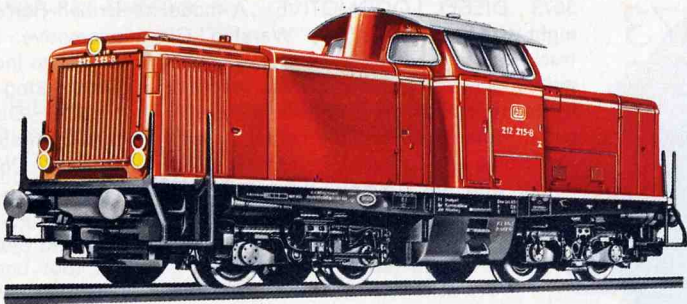

3072

3072 DIESEL LOCOMOTIVE · A model of the two truck (BB) Class 212 (V 100) diesel of the German Federal Railways · Four wheel drive with rubber tires to increase the pulling power · Remote control reversing · Three working headlights at each end · Die cast metal under-frame with solid buffers · Red plastic body with fine details, scale handrails · Windows inset in plastic frames · Automatic couplers (RELEX) at each end · 5½" long over buffers

The front and rear cabs of the 3072 have been kept narrow as on the prototype, due to a specially designed motor and gear arrangement.

The 212 (V 100) is a multi purpose diesel a full 40 feet long and weighing 63.2 tons. The new types have 1350 horse power, which is transmitted hydraulically through universal drive shafts to all four axles. —

In order to use the locomotive for both freight and passenger service a special dual ratio transmission is provided, that can be operated from the cab. In the low ratio the locomotive has maximum power but a fairly low speed 44 mph, while in high ratio it reaches speeds of 65 mph.

Diesel Locomotive "216" (V 160)

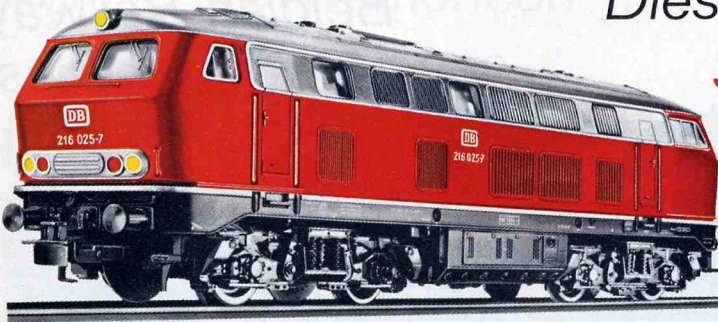

3075

3075 DIESEL LOCOMOTIVE · A model of the eight-wheeled 0-4-4-0 Class 216 (V 160) of the German Federal Railways · Four wheel drive with rubber tires to increase the pulling power · Remote control reversing · Three working headlights at each end · Red and grey plastic body with scale details, grey roof · Windows inset in plastic frames with simulated windshield wipers · Die cast metal frame with solid buffers · Automatic Advance couplers (RELEX) at each end · 7" long over buffers

The 216 (V 160) locomotive designed for medium mainline service, develops 1900 hp giving it a maximum speed of 75 mph. It is 52 feet long and weighs 79 tons fully serviced.

HAMO

8375

The same model as 3075, but for operation on two rail, D.C. (see also page 12)

Diesel Hydraulic Express Locomotive "220" (V 200)



3021

3021 DIESEL LOCOMOTIVE · A model of the German Federal Railways 220 (V 200) locomotive with two 4 wheel trucks (BB) · Four wheel drive with rubber tires to increase the pulling power · Remote control reversing · Three working headlights at each end · Red and grey all metal body with solid buffers and grey roof · Frosted plastic windows · Automatic advance couplers at each end · 8¼ in. long over buffers



British "Warship Class" Diesel Locomotive



3073

3073 DIESEL LOCOMOTIVE · A model of British Rail's (BR) eight-wheeled 0-4-4-0 (BB) "Warship" Class locomotive · Power truck with four wheel drive, four special rubber tires to increase pulling power · Remote control reversing · Two working headlights front and rear · Plastic body with fine details · Die cast metal underframe for low center of gravity · Dark green body and frame with grey roof · Frosted plastic windows · Coupling hooks with the Advance uncoupler at both ends · 8⁵/₁₆" long over buffers

The "Warship" Class locomotives were built in British Rail's Swindon Works in 1958 to the design of the German 220 (V 200) locomotive. All locomotives of this type bear names such as "Formidable", "Albion", "Majestic" and so on. Transmission is hydraulic, and the power developed is 2200 H.P.



3066

Belgian Railways Diesel Locomotive

3066 DIESEL LOCOMOTIVE · A model of the Belgian State Railways (SNCB) Twelve-wheeled 0-6-6-0 (Co'-Co') Type 204 locomotive · Three axles are driven and four rubber tires to increase the pulling power · Remote control reversing · Three working headlamps front and rear · Green metal body with black roof, fixed buffer beams and inset windows with plastic frames · Coupling hooks at both ends · 8 in. long over buffers

The Belgian Type 204 locomotives are also engaged in hauling light goods trains as well as passenger and express trains. They have diesel-electric drive and develop a total of 1750 H.P., giving them a maximum speed of about 87¹/₂ miles an hour.

Danish Railways Diesel-Electric Locomotive



3067

3067 DIESEL LOCOMOTIVE · A model of the twelve-wheeled 0-6-6-0 (Ao 1Ao) Type My 1100 Statsbaner (D.S.B.) · Three axles are driven and there are four special rubber tires to increase the pulling power · Remote control reversing · Three working headlights, front and rear · Red-brown die cast metal body with grey roof and fixed buffer beams · Inset windows with plastic frames · Coupling hooks at each end · 8 in. long

The My 1100 Type diesel-electric multi-purpose locomotive on the Danish State Railways (DSB) are very similar to the Belgian Type 204. They have diesel-electric drive. Among other services they haul the international expresses over the direct "Vogelflug" connection (the line "as the crow flies").

**- in case of snow,
mud and
cold -**

MÄRKLIN



Norwegian Railways Diesel-Electric Locomotive

3068



3068 DIESEL LOCOMOTIVE · A model of the Norwegian State Railways' (Norske Statsbaner, or N.S.B.), twelve-wheeled 0-6-6-0 (Co-Co) Type Di 3 locomotive · Three axles are driven and there are four rubber tires to increase the pulling power · Fitted with reversing gear · Three working headlights front and rear · Redbrown all-metal body with silver roof and roof fittings · Fixed buffer beams, inset windows with plastic frames · Coupling hooks at both ends · 8 in. long over buffers

Diesel locomotives are being used in increasing numbers on the Norwegian State Railways' lines in regions that are not yet electrified. The diesel engine of the Type Di 3 develops 1900 H.P. with which the locomotive can reach a maximum speed of some 62½ miles an hour. In general design this locomotive resembles the Belgian Type 204 and also the Danish Type My 1100 locomotives, but has more detail.

3060

American "F 7" Diesel Locomotive of the Santa Fé Railway



4060

4060 DIESEL LOCOMOTIVE WITHOUT POWER, to match the 3060 Santa Fé locomotive · Eight-wheeled · Working headlights · All metal body with clear plastic windows · Equipped with Advance coupler on the front · 6⁷/₈ in. long

3060 DIESEL LOCOMOTIVE · A model of the American Type F 7 eight-wheeled 0-4-4-0 (Bo-Bo) locomotive built by the Electro-Motive Division of General Motors for the Santa Fé Railroad · Remote control reversing · Two axles are driven and there are four rubber tires to increase pulling power · Working headlights, scale model lighting · All-metal body, plastic frosted windows · Coupling hook with the Advance uncoupler at cab end, and automatic coupling with the RELEX Advance coupler at the trailing end · 6⁷/₈ in. long

3061

American "F 7" Diesel Locomotive of the Union Pacific Railroad



4061

4061 LOCOMOTIVE WITHOUT POWER to match the 3061 Union Pacific locomotive · Eight-wheeled · Working headlights · All metal body with clear plastic windows · Equipped with the Advance coupler on the front · 6⁷/₈ in. long

3061 DIESEL LOCOMOTIVE · A model of the American F 7 eight-wheeled locomotive built by the Electro-Motive Division of General Motors for the Union Pacific Railroad · Remote control reversing · Two axles are powered and four wheels are fitted with special rubber tires to increase the pulling power · Working headlights · All metal body with clear plastic windows · Front and rear couplers with Advanced coupler at the front and RELEX Advance uncoupler at the rear · 6⁷/₈ in. long



Railbus and Trailer



3016 RAILBUS · A model of the German Federal Railways 795 (VT 95) unit · Four-wheeled, with one axle driven and rubber tires to increase pulling power · Remote control reversing · Working headlights at both ends, with interior lighting by two bulbs · Red plastic body with cast metal frame and windows glazed with cello · Special couplings at both ends for close-coupling the cars together · 57/8 in. long over buffers

4018 RAILBUS TRAILER · A model of the German Federal Railways 995 (VB 142) unit · Four-wheeled, with plastic body and windows with cello glazing · Red tail lights at both ends and one bulb for interior lighting · Pickup shoe for lighting current · Special coupling to fit railbus only · 4¾ in. long over buffers

new

3071 "TEE"
Express Train



The TEE Train illustrated consists of the 3071 three car set plus the 4071 First Class Coach making the normal four car train. The length of the complete train is 37 in.



3071 TEE EXPRESS TRAIN, three unit · A model of the Netherlands-Swiss TRANS-EUROP-EXPRESS train · Consists of locomotive, combination first class and restaurant car, and spacious first class compartment car with engineers compartment · The train measures 27½" long
The locomotive has two 6 wheeled trucks with three axles driven, four rubber tires to increase the pulling power · Remote control reversing · Dull black die cast metal underframe with engineers seats · Plastic body finished in correct red and beige TEE colors · Grey roof · Clear windows inset in frames
The remaining two cars have four wheeled trucks as on the prototype · Plastic bodies finished in the correct red and beige TEE colors · Grey roofs · Clear windows inset in frames
The three units are connected by special close fitting couplers and have operating diaphragms between the cars · Both ends of the train have three white headlights and two red taillights · All change automatically when the train is reversed · A current collector is on each end of the train, the front one in the direction of travel picks up the motor current

...if a weekend is spoiled by rain-

MÄRKLIN



Two Unit Electric Railtrain

3076 TWO UNIT RAILTRAIN · A model of the battery powered multiple unit train Class 515/815 (ETA 150 + ESA 150) of the German Federal Railways

Rail Motor Car: 8 wheeled with four wheels driven · All driving wheels equipped with rubber tires to increase pulling power · Reversing by remote control · Red plastic body · Interior fittings with lighting system · Plastic windows inset in frames · Silver roof

Trailer Car: 8 wheeled · Connected to the Motor Car by a permanent coupling · Red plastic body · With complete interior · Seating arrangement, 2 seats on each side of center aisle · Interior lighting system · Plastic windows inset in frames · Silver roof

Both units equipped with three headlights that show white when running forward and automatically change to two red lights when reversed · Coupler hooks at each end · Length of train over buffers 19 1/2"

3076

The Motor Railcar Class 515 (ETA 150)—usually coupled to Trailer Car 815 (ESA 150)—are used on both branchline railway divisions and on main divisions in express and passenger service. The range of operation is limited to about 200 miles because of the performance of the storage batteries carried as the power source. Two motors with an hourly output of 270 hp enable the train to reach a top speed of 60 mph. The Motor Car and the trailer each measure 46 ft. in length, with the Motor car weighing 56 tons and the Trailer weighing 23 tons.



HAMO 8376

The same model as 3076 but for two rail, DC operation (also see page 12)



TRANS EUROP EXPRESS

Five complete trains of the Netherlands-Swiss TRANS-EUROPEAN-EXPRESS are now in service, which operate from Zurich to Amsterdam as the TEE "Edelweiß" and from Zurich to Munich as the TEE "Bavaria". The locomotive has three diesel engines with a total of 2300 hp, giving the train a top speed of 87 1/2 miles per hour. The windows do not open in the cars, due to the high speed and the air conditioning system. As in all TEE trains, there are only first class cars, each with 114 seats. The dining car has room for 32 diners.

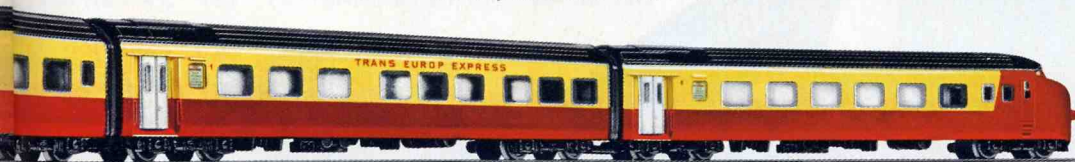

new 4071

4071 TEE FIRST CLASS COMPARTMENT COACH · Two 4 wheeled trucks · Plastic body finished in the correct red and beige TEE colors · Roof grey · Clear windows inset in frames · Movable diaphragms at each end of car · Special couplers to connect to TEE train · 9" long







Passenger Cars with Automatic Coupling and Uncoupling



4000 4000 PASSENGER COACH · Platform and doors at each end · Open windows · Dark green body, grey roof · 4 1/2" long over buffers

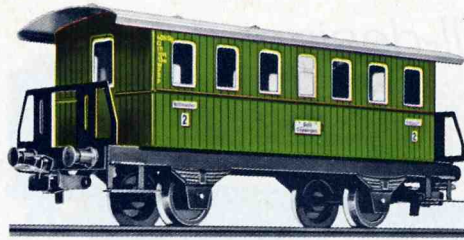

4040 4040 PASSENGER COACH · Four-wheeled, with platforms and entrances at both ends · Cut-out windows · Coach body green with silver-grey roof · Length about 4 1/2" over buffers

Coaches from the "good old days," these cars that first began service more than 50 years ago are still in service in some areas. They are especially appropriate when used with the tank locomotive 3029 (see pages 2 and 8). This will provide you with an exact replica of many of the trains that operated in Europe around the turn of the century.

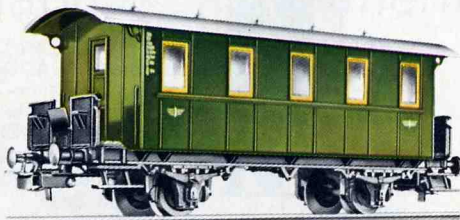

new
4007

4007 PASSENGER COACH · 4 wheeled · Used by private railways · Black plastic platform and railings on each end · Dark green plastic body · Silver roof · Imitation ventilators · Clear plastic windows inset in frames · Coaches have complete interiors · 4 1/4" long · For lighting the interiors use set 7323 (see page 56)

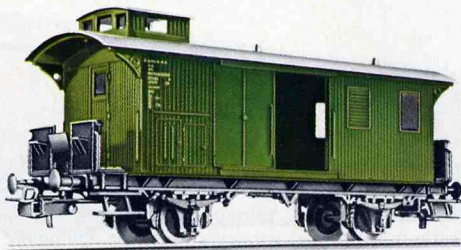

new
4008

4008 LUGGAGE VAN · 4 wheeled · A model of the Stuttgart Railways private car · Platform and door on each end · Dark green plastic body · Silver roof with imitation ventilators and cupola · 4 1/4" long · For lighting the interiors use set 7323 (see page 56)

Branchline passenger cars. Designed to accept interior lighting. Dark green body. Grey roof. 5 1/4" long over buffers.

4002

4002 PASSENGER COACH with end platforms and entrances · 4 wheeled · Windows glazed with cello · A reproduction in miniature of the Bi 28 standard passenger coach on the German Federal Railways

4004 COMPARTMENT COACH · Six-wheeled, sides opening into six compartments · Designed to accept interior lighting 7074 · Windows glazed with cello · Body dark green with grey roof · Numerous inscriptions and markings · Length 5 1/4" over buffers

4004

4005

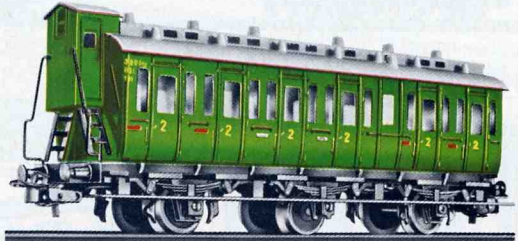

4005 COMPARTMENT COACH WITH BRAKEMAN'S CABIN · Six-wheeled with doors for six compartments · Designed to accept interior lighting 7074 · Clear plastic windows · Dark green body with grey roof · Length over buffers 5 1/4"

4079 PASSENGER CAR · Second class, six-wheeled coach · A model of the German Federal Railways' type B3yge · Dark green body with inset plastic window frames · Simulated rubber diaphragms on ends · Silver roof · Length 6" · Provision for fitting the 7074 lighting equipment (see page 56)

4079

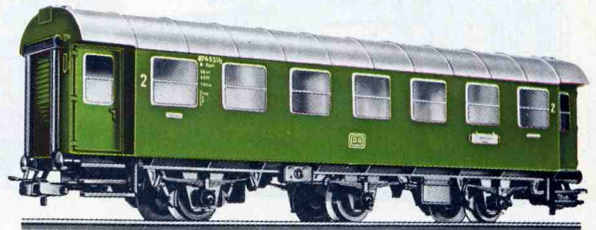

4080



4080 PASSENGER CAR WITH BAGGAGE COMPARTMENT · Second class, six-wheeled coach · A model of the German Federal Railways type BD3yge · Dark green body with inset plastic window frames · Simulated rubber diaphragms on ends · Silver roof · Length 6" · Provision for fitting the 7074 lighting equipment (see page 56)

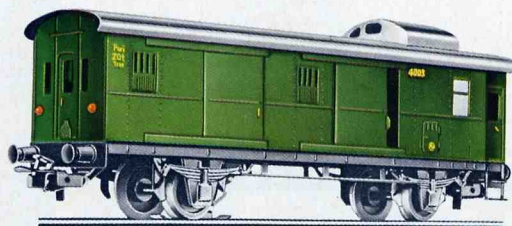

4041

4041 LUGGAGE VAN with sliding doors both sides and roof look-out for guard's compartment · A miniature reproduction of the Di 28 van on the German Federal Railways

4003

4003 LUGGAGE VAN like 4041, but without tail lights and current pickup shoe

TEE -Coaches with Full Scale Interiors
exclusive and
well-designed



We offer here, the stars of the German Federal Railways, the TEE cars for operation with electric locomotives (different from the diesel TEE train on page 24). These are the best equipped, most comfortable and undoubtedly the most beautiful equipment on the German Federal Railways. We have retained all these fine features in the models (the design of the cars is the same as the express coaches on pages 30/31).

4090 TEE DOME CAR · First Class · A model of the German Federal Railways eight-wheeled Type ADm coach · Body painted red and beige · Removable silver roof · Frosted glass windows inset in frames · Car has complete interior · Vista-dome compartment · 9 1/2" long · Interior can be lighted using lighting equipment 7322 (page 56)



4090

4085 TEE COMPARTMENT COACH · First Class · A model of the German Federal Railway's Type Avm eight-wheeled coach · The body is finished beige and red with dark-grey fairing and detachable silver-colored roof · Inset plastic-framed windows · The coach has the interior equipment already fitted, with a side corridor · 9 1/2" long · For lighting by interior lighting set 7320 (page 56)



4085



4089

4089 TEE COMPARTMENT COACH · First Class · As No. 4085 coach, but fitted with current pickup, fittings for interior lighting and tail lights

4086 TEE CHAIR CAR · First Class · A model of the German Federal Railway's eight-wheeled Apm type coach · Body finished beige and red, with dark grey fairing and detachable silver-colored roof · Inset plasticframed windows · The interior equipment is already fitted with centre corridor and the 1-2 seating arrangement · 9 1/2" long · For lighting by interior lighting set 7320 (page 56)



4086

4087 TEE RESTAURANT CAR · A model of the German Federal Railway's eight-wheeled Type WRm car · Body finished beige and red with dark grey fairing · Detachable silver-colored roof and plastic-framed inset windows · Interior equipment is fitted, divided up into the kitchen and restaurant compartments · 9 1/2" long · To light up by interior lighting set 7320 (page 56)



4087

**...and when the
sun is shining
bright-**

MÄRKLIN



Commuter Coaches of the German Federal Railways with Interiors

4082 LOCAL PASSENGER COACH · Second Class · Model of the German Federal Railways Type (B4nb) · Two 4 wheeled bogies · Body in stainless steel color with peacock-eye pattern · Modern scale lettering · Fitted with complete interiors · Plastic windows inset in frames · Removable roof in silver with grey weathering · 9 1/2" long · Interior can be lit using 7077 lighting set and current pickup shoe 7198 (see page 56)



4082

4083 LOCAL PASSENGER COACH · First and second Class · Model of the German Federal Railways Class (AB4nb) · Two 4 wheeled bogies · Body in stainless steel color with peacocks-eye pattern · Modern scale lettering · Fitted with complete interiors · Plastic windows inset in frames · Removable roof in silver color with grey weathering · 9 1/2" long · Interior can be lit using 7077 lighting set and current pickup shoe 7198 (see page 56)



4083

With Drivers Cab and Baggage Compartment

4081 LOCAL PASSENGER COACH WITH DRIVERS CAB AND BAGGAGE COMPARTMENT · Second Class · Model of the German Federal Railways Type BD4nf · Two 4 wheeled bogies · Body in stainless steel color with peacocks-eye pattern · Modern scale lettering · Fitted with complete interiors · Plastic windows in inset-frames · Removable roof with dummy signal horn · Head lights on Driver's Cab end of car which change from three white lights when running forward to 2 red lights when running in reverse · 9 1/2" long · Interior can be lit using 7077 lighting set (see page 56)



4081



4088

MARKLIN - HAMO
for two rail
D. C. operation

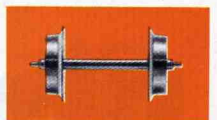

7589

7589 SET OF WHEELS, consisting of 4 axle sets · For converting the TEE Coaches as shown on page 28 and 29 for two rail operation

4088 TEE BAR CAR · A model of the German Federal Railways' Type ARDm eight-wheeled car · Body finished beige and red with dark grey fairing and detachable silver-colored roof · Inset plastic-framed windows · Interior equipment is fitted, divided up into the bar, passenger and train crew's compartments · 9 1/2" long · To light up by interior lighting set 7320 (page 56)



Passenger Cars for the German Federal Railways

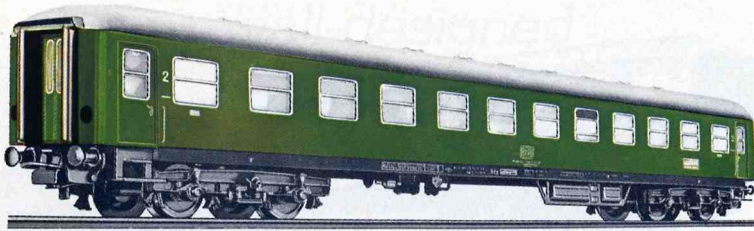

4022

4022 EXPRESS COACH · Second Class · A model of the German Federal Railways' eight-wheeled Class B 4 üm Coach · Detachable roof · Inset windows with plastic frames · Dark green body with silver roof shaded grey · 9 1/2" long over buffers



4024

4024 EXPRESS RESTAURANT CAR · A model of the German Sleeping and Restaurant Car Company's eight-wheeled car (DSG—Deutsche Schlafwagen- und Speisewagengesellschaft) · Wine-red body with detachable silver roof, shaded grey · Inset windows with plastic frames · Ivory lettering · 9 1/2" long over buffers



4029

4029 EXPRESS SLEEPING CAR · A model of the International Sleeping Car Company's Type ISG No. 4581 eight-wheeled car (ISG—Internationale Schlafwagengesellschaft) · Body finished blue with detachable silver roof shaded grey · Inset plastic-framed windows, lettering etc. exactly as on the full-sized original · Scale model diaphragms at each end · 9 1/2" long



4037

4037 EXPRESS COACH · Second Class · A model of the German Federal Railways earlier type eight-wheeled coach · Body finished in green with detachable grey roof, frosted glass windows · Scale model diaphragms at each end · 8 3/4" long



4078

4078 EXPRESS COACH · First Class, with restaurant compartment · A model of the German Federal Railways' eight-wheeled ARüm 65 type coach · The First Class Compartment is finished blue and the restaurant compartment in red on the outside · Inset plastic-framed windows · Silver roof, shaded grey at edges · 9 1/2" long · To light the coach use the 7320 lighting set (see page 56)

**... pleasure-
all year
long**



Scale H0



Our express passenger cars have all metal or plastic bodies. Plastic window panes and frames are inset separately. All door markings, details and scale lettering are true to the prototype, giving you a car that is as close to the original as possible. The cars are finished with mat finish for an appropriate look. The cars are designed for interior lighting. The Minden-Deutz design bogies have movable side frames which compensate for any unevenness in the track allowing the cars to run smoothly without derailments. The cars have simulated rubber diaphragms at each end, and are equipped with automatic Advance couplers (RELEX).



4032

4032 EXPRESS COACH · First Class · Similar to 4027 but with pick up shoe and taillights

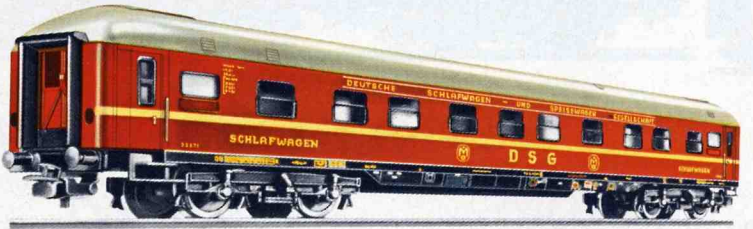
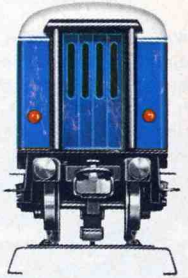

4027

4027 EXPRESS COACH · First Class · A model of the German Federal Railways' eight-wheel type A 4 üm coach · Body finished in blue with detachable silver roof, shaded grey, and inset plastic-framed windows · 9 1/2" long over buffers



4064

4064 EXPRESS SLEEPING CAR · First and Second Class · A model of the German sleeping and Restaurant Companies (DSG) WL AB 4 üm Series 33200 car · Wine red body with detachable silver weathered roof · White lettering · Plastic inset windows · 9 1/2 in. long



4047

4047 EXPRESS MAIL VAN · A model of the German Federal Post Office eight-wheeled type "Post 4m-b/26" van · Dark green body with detachable silver roof, shaded grey · Inset plastic-framed windows, yellow lettering · 9 1/2" long

4044

4044 EXPRESS BAGGAGE CAR · Similar to 4026 but with pick-up shoe and tail lights

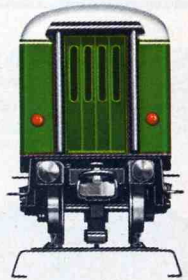

4026

4026 EXPRESS LUGGAGE VAN · A model of the German Federal Railways' D 4 ym type eight-wheeled van · Dark green body with detachable silver roof shaded grey, inset plastic-framed windows, ivory lettering · 9 1/2" long over buffers

Interior Equipment for Coaches 4022, 4024, 4027, 4032, 4033, 4036, 4037, 4045, 4065, 4066, 4069, and 4075



The interior sets and figures are molded of finely detailed plastic, with figures handpainted. Illustrated installation instructions are included with each set.

0226

0226 SET OF 10 SEATED PASSENGERS, pre-painted for completing the 0225 interior equipment set

0224 SET OF INTERIOR EQUIPMENT for the 4024 Restaurant Car with ten seated diners, hand painted, red seats and white tables

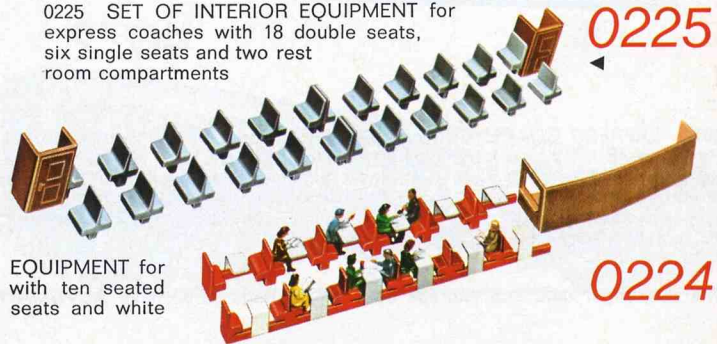

0225

0225 SET OF INTERIOR EQUIPMENT for express coaches with 18 double seats, six single seats and two rest room compartments

0224



Lightweight Coaches of the Swiss Federal Railways

4066 PASSENGER COACH · A model of the Swiss Federal Railways' eight-wheeled Series A 2500 coach · Green body with yellow longitudinal bands under the roof · Inset windows with hand rails fitted inside · Imitation rubber beadings at ends · Detachable silver-colored roof with longitudinal ribs and simulated ventilators · 9½" long · To light up by interior lighting set 7320 (page 56)

4066



4068 DINING CAR · Model of the RIC Dining Car of the Swiss Federal Railways · Two four wheel bogies · Red body with yellow lettering · Inset plastic frame windows · Simulated rubber diaphragms on ends · Silver removable roof with lengthwise ribs · Roof mounted pantograph · Length 9½" · Car can be lighted using 7077 lighting equipment (page 56)

4068

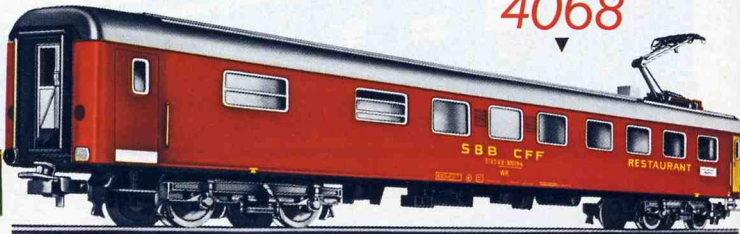

Italian Railways Passenger Coach

4036



4036 PASSENGER COACH · Second Class · A model of the Italian State Railways (FS-Ferrovie dello Stato) eight-wheeled Type Fs Bz 33010 coach · Brown and beige body with detachable silver roof · Frosted Glass windows · Scale model diaphragm at each end · 8¾" long

French

4050



4050 EXPRESS COACH · First Class · A model of the French stainless steel eight-wheeled Class A 8 myfi coach · Plastic body in true coloring of the original with inset plastic-framed windows · 9½" long · Provision for fitting the 7197 lighting equipment (page 56)

Swedish Railways Express Coaches

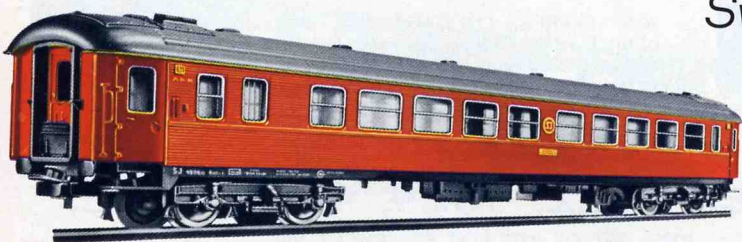

4072

4072 EXPRESS COACH · Second Class · A model of the Swedish State Railways' (S.J. Statens Järnvägar) eight-wheeled Class Bo 1 coach · Brown high-grade plastic body grey roof · Inset plastic-framed windows · Imitation diaphragm connections at the ends · Fine detail of all accessories and fittings on lower part of body · 9⅓" long · Provision for fitting the 7197 lighting equipment (page 56)

4073

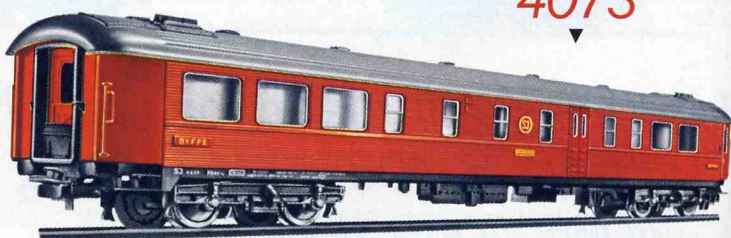

4073 EXPRESS RESTAURANT CAR · A model of the eight-wheeled Class RBo 2 car on the Swedish State Railways · Brown high-grade plastic body with grey roof and inset plastic-framed windows · Imitation concertina connections at the ends · Fine detail of all accessories and fittings on lower part of body · 9⅓" long · Provision for fitting the 7197 lighting equipment (page 56)

The passenger cars and express coaches on page 32/33 have AUTOMATIC ADVANCE COUPLERS (RELEX) and will accept interior lighting (see page 56).

**A fascinating
hobby—
A great way
to relax—**

MÄRKLIN



Netherland Railways Express Coaches

4048



4049



4048 EXPRESS MAIL VAN · A model of the Netherlands Railways' (N.S.—Nederlandse Spoorwegen) eight-wheeled P 7900 type mail van · Blue body with detachable dark grey roof · Inset plastic-framed windows and white lettering · Imitation diaphragm connections at the ends · 9½" long

4049 EXPRESS COACH · Second Class, with seating accommodation · A model of the Netherlands Railways' eight-wheeled Type B 6600 coach · Body finished blue, with dark grey detachable roof · Inset plastic-framed windows—some opened—and white lettering · Imitation diaphragm connections at the ends · 9½" long

Railways Express Coaches

4075

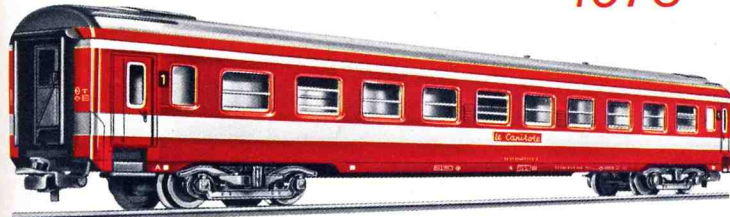

4065



4075 EXPRESS COACH · First Class · A model of the French State Railways' eight-wheeled "Le Capitole" type coach · Red body with longitudinal white bands and detachable grey roof · Inset plastic-framed windows · 9½" long · To light up by the 7320 interior lighting set (page 56)

4065 EXPRESS COUCHETTE CAR · A model of the Second Class standard U.I.C. (International Union of Railways) eight-wheeled Y type coach on the French Railways (SNCF) · Body and detachable roof dark green, roof shaded black · Inset plastic-framed windows · 9½" long

*Belgian Railways
Express Coach*

4069

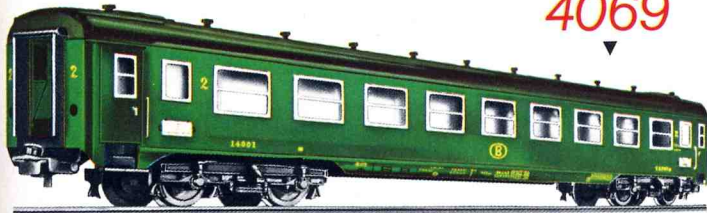

*Danish Railways
Express Coach*

4045

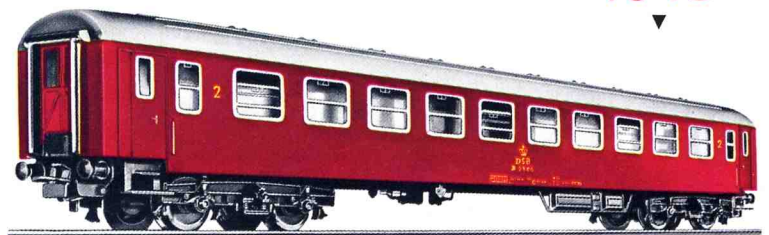

4069 EXPRESS COUCHETTE CAR · Second Class · A model of the Belgian State Railways' (S.N.C.B.—Société Nationale des Chemins de Fer Belges) eight-wheeled RIC couchette car · Body and detachable roof dark green, with simulated ventilators · Inset plastic-framed windows · 9½" long · To light up by interior lighting set 7320 (page 56)

4045 EXPRESS COACH · Second Class · A model of the Danish State Railways' (D.S.B.—Danske Statsbaner) eight-wheeled B 2300 Class coach · Reddish-brown body with detachable silver roof, shaded grey · Inset plastic-framed windows · 9½" long over buffers

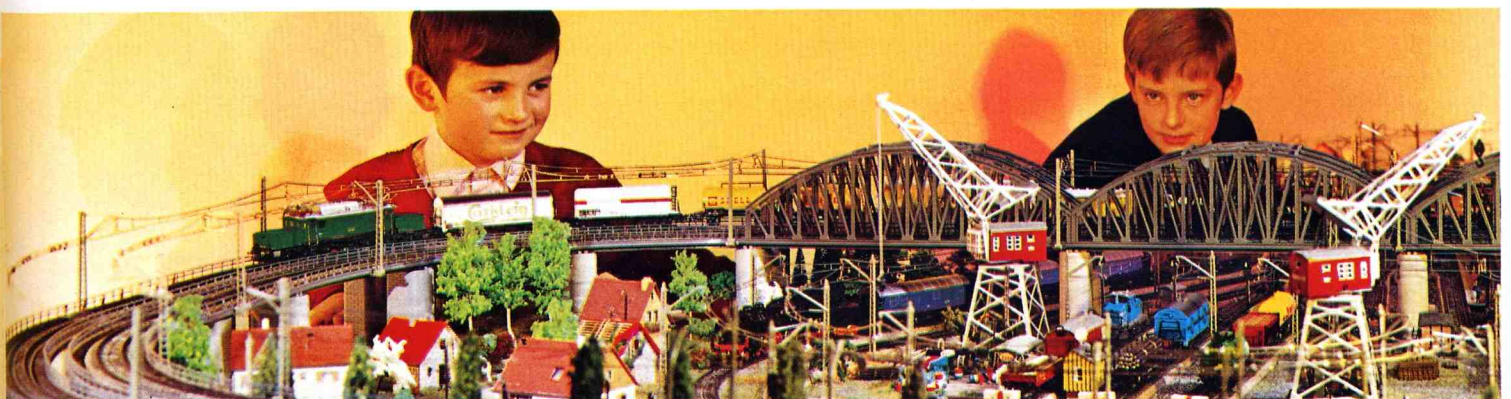





Freight cars with detailed plastic bodies and automatic couplers (RELEX = with delayed action)



4500 4500 TANK CAR · Silver · "ARAL" · RELEX couplers · 4 in. long



4501 4501 TANK CAR · Silver · "ESSO" · RELEX couplers · 4 in. long



4502 4502 TANK CAR · Yellow · "SHELL" · RELEX couplers · 4 in. long

The trucks on these cars are die cast metal finished dull black. The wheels are fine turned. The bodies (except 4512) are finely detailed plastic castings. All lengths are measured over the buffers.



4503 4503 LOW SIDE GONDOLA · Brown · RELEX couplers · 4 in. long



4505 4505 BOX CAR · Brown · Silver roof · RELEX couplers · 4 in. long



4506 4506 BOX CAR · Brown · Silver roof · Finely modeled working taillights · Pick up shoe · RELEX couplers · 4 in. long



4508 4508 REFRIGERATOR CAR · White with black lettering · Ventilators on roof · RELEX couplers · 4 in. long

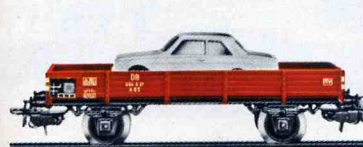

4504 4504 LOW SIDE CAR · Brown · Loaded with automobile · RELEX couplers · 4 in. long

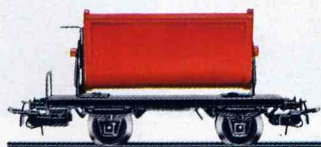

4513 4513 DUMP CAR · Red · Will dump to either side · Locking lever · RELEX couplers · 3 3/8 in. long



4510 4510 WINE CAR · Tan barrels lettered "BORDEAUX" · RELEX couplers · 4 in. long



4511 4511 PULVERIZED COAL WAGON · Two aluminium colored coal containers with fillers connected by a walkway · RELEX couplers · 4 in. long



4514 4514 LOW SIDED CAR · Brown · Eight-wheeled · Without advance couplers · 7 1/4 in. long

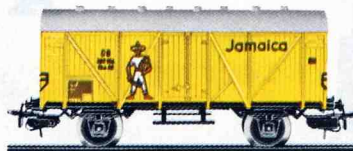

4509 4509 BANANA REFRIGERATOR CAR · Yellow · White roof · RELEX couplers · 4 in. long

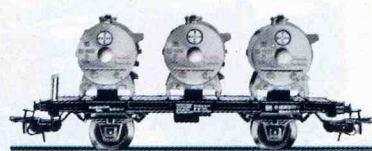

4520 4520 CHEMICAL CONTAINER CAR · With three round containers that can be removed by the 7051 Crane · Silver containers lettered "BAYER" with black frame · RELEX couplers · 4 1/4" long

4512 4512 DOUBLE LUMBER CAR · With load of real lumber · All metal double unit · Black · RELEX couplers · 7 1/2 in. long



4517 4517 COVERED FLAT CAR · Brown · Eight-wheeled · White cover · Without advance couplers · 7 1/4 in. long

...all year long

MARKLIN - pleasure

Scale Model Freight Cars 4600 with Automatic



4619

4619 GONDOLA WITH SLIDING ROOF · A model of the German Federal Railways' Type Kmmks 51 · Four-wheeled · The two roof halves slide over each other · Brown body · Silver roof · 4 1/2 in. long



4602

4602 OPEN GOODS CAR · German Federal Railways' Type Omm 52 · Brown · 4 1/2 in. long



4601

4601 OPEN GOODS CAR, with brakeman's cabin · German Federal Railways' Type Omm 33 · Brown · 4 1/2" long



4604

4604 OPEN GOODS CAR · German Federal Railways' Type Omm 52 · Brown · With removable load of imitation coal · 4 1/2" long



4605

4605 SWISS BOX CAR, with brakemans cabin · Swiss Federal Railways' Type SBB-K³ · Brown · Silver roof · Both doors open · 4 1/2" long



4607

4607 LOW SIDE CAR WITH STAKES · German Federal Railways' Type Rmms 33 · With detachable stakes stored in sliding case underneath car floor · Brown · 5" long



4612

4612 AUTOMOBILE TRANSPORTER · Not loaded · Brown · Black loading Ramp · 4 1/2 in. long · (On the German Federal Railways these cars are used in pairs and the unit is then designated Type Off 52)



4610

4610 BALLAST CAR · With unloading doors operated by crank lever · Brown · 3 3/4" long

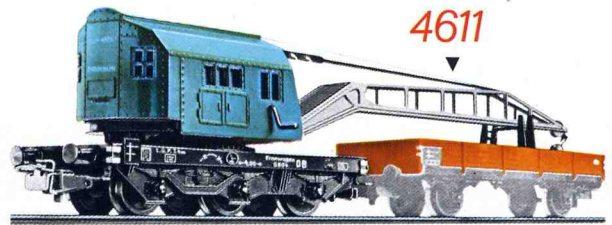

4611

4611 CRANE CAR · With revolving boom and boom adjustment support · Crank handle to raise and lower the crane hook · Black underframe · Blue Cab unit · Silver boom · 3 5/8 in. long · (The 4503 car is not included, but is recommended for supporting the boom when the crane is in transit)

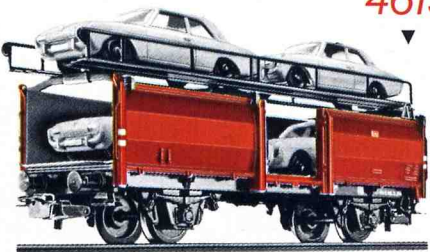

4613

4613 AUTOMOBILE TRANSPORTER with loading ramp · Loaded with miniature cars · Brown · Black loading Ramp · 4 1/2" long

A fascinating hobby-

WHEEL SETS
for two rail operation

MARKLIN - HAMO

7588

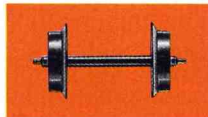

7588 WHEEL SET, consisting of four axle sets · For converting all 4600 type cars (except 4611, 4617, 4618, 4631, 4633, 4635, 4644, 4645, 4646, 4656, 4657, 4659 and all eight-wheeled cars) to two rail operation

7587

7587 SET OF WHEELS, consisting of three axle sets · For converting cars 4611, 4617, 4618, to two rail, D.C. operation

4617 DEPRESSED CENTER FLAT CAR · Twelve-wheeled · Loaded with removable transformer · Black · Silver transformer · 10" long

4617

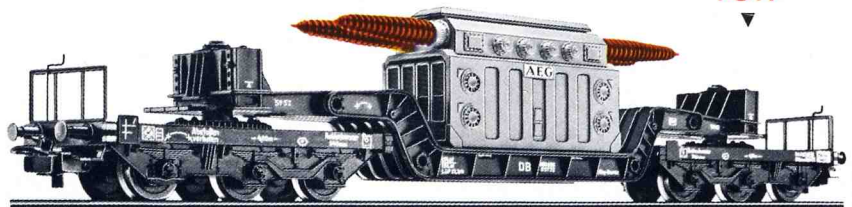

4618

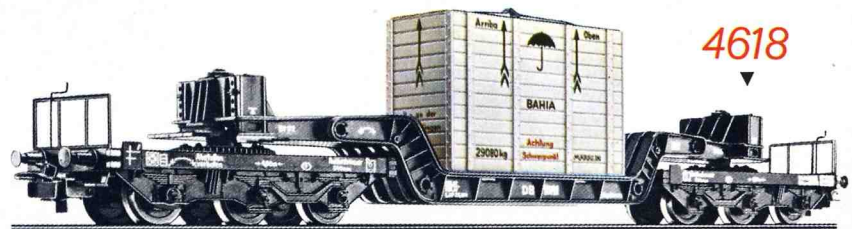

4618 DEPRESSED CENTER FLAT CAR · Twelve-wheeled · Loaded with removable packing case · Black · Wood colored case · 10" long



Coupling and Uncoupling (RELEX)



4600

4600 FREIGHT TRAIN LUGGAGE VAN (CABOOSE) · German Federal Railways' Type DB-DG · Green · Grey roof · Both doors slide open and closed · 3³/₈" long

The model freight cars are extremely reliable operating. They include many more details than our regular cars. A most important feature is the RELEX coupler which allows delayed action uncoupling. After the coupler is open with the uncoupler track, it remains open so that you may spot the cars farther down the track without the cars recoupling. All cars without the RELEX couplers will still couple with cars equipped with RELEX couplers.



4620

4620 REFRIGERATOR CAR · Four-wheeled · Model of the German Federal Railways' Type Tehs 50 · White with black lettering · Imitation ventilators on roof · 5¹/₄" long



4621

4621 HIGH CAPACITY TANK CAR · Eight-wheeled · Model of the German Federal Railways' Type Ksl 3504 · White tank with lengthwise red stripes and the name "MARKLIN" in blue · Underframe black · 5¹/₄ in. long

Cars of this type are used in international traffic for carrying coal, coke, minerals and similar goods. They are usually made into unit trains that are not broken up until they reach their final destination.



4624

4624 HIGH CAPACITY GOODS CAR · Eight-wheeled · Model of the German Federal Railways' Type OOtz 50 · Brown with prototype lettering in white · 5¹/₄" long



4628

4628 PRESSUREIZED GAS TANK CAR · Eight-wheeled · Grey tank with yellow stripes · Black underframe · Private owner car of the VTG (Vereinigte Tanklager und Transportmittel GmbH) · 7³/₄ in. long



4627

4627 VENTILATED BOX CAR · Four-wheeled · German Federal Railways' Type Glimmehs 57 · Brown body with silver vent doors · Silver roof · 5¹/₄ in. long



4626

4626 HIGH CAPACITY GOODS WAGON WITH HINGED ROOF COVERS · A model of the German Federal Railways' eight-wheeled KKt 57 Type wagon · Brown with all covers to open · 5¹/₄ in. long

This series of cars has a roof with hatches so that goods that are subject to damage from the elements, such as grain, can be transported in safety.

Great relaxation-

4625 CONTAINER CAR, with brakeman's cabin · Four-wheeled · Loaded with one box type container and two cylinder containers · Can be unloaded using the 7051 Crane · Silver containers · Black underframe · 4¹/₄ in. long

4625

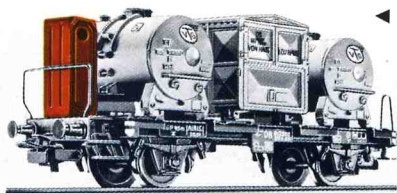

MARKLIN

4631

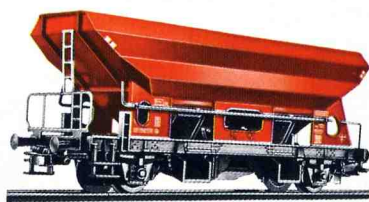

4631 SIDE DUMPING CAR WITH OPENING DOORS · Four-wheeled · Model of the German Federal Railways' Type Otmm 70 · Brown plastic body · Black die cast metal underframe · 4¹/₂ in. long

The discharging doors can be operated by the hand lever, or automatically by using to 5112 uncoupling track section (see page 42) and 2197 (see page 48)

4632



4632 BEER TANK CAR · Eight-wheeled · White tank lettered, "Feldschlößchen Bier" · Underframe black · 7³/₄ in. long

4635

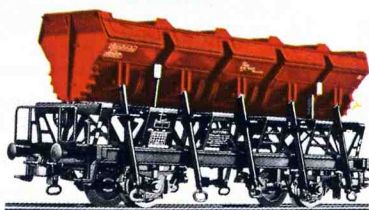

4635 DUMP CAR · Four-wheeled · Model of the German Federal Railways' Type Ommi 51 · All released · Brown body · Black underframe · 4¹/₂ in. long

4633

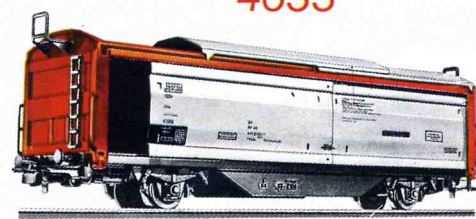

4633 GOODS WAGON WITH SLIDING DOORS AND ROOF · German Federal Railways' Type KImmgs 66 · Four-wheeled · Sides and roof slide open in both directions · Main body brown · Sides and roof silver · Scale lettering, exactly as on the original · 6¹/₈ in. long

Scale Model Freight Cars with Automatic Coupling



4634 Available Again



4634 BEER REFRIGERATOR CAR · 4 wheeled · Model of the private car of the Dortmunder Union Brewery · White with red lettering · Firm logo on blue background with yellow "U" · 5 1/4" long

4637



4637 BOX CAR · Four-wheeled · German Federal Railways Type Tnomehs 59 · Brown, Silver roof · Lettered as a Banana Car · 5 1/4" long

4639



4639 OPEN GOODS CAR · Four-wheeled · Model of the Netherlands State Railways (NS) · Tuscan red body · 4 1/2" long

4640

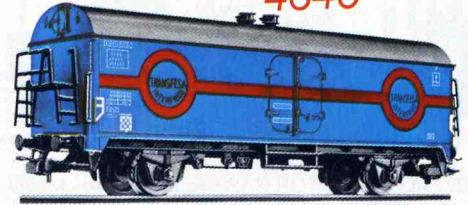

4640 REFRIGERATOR CAR · Four-wheeled · A model of the private form of TRANSFESA · Blue body · Red stripes and rings · Silver roof, black underframe, with scale roof ventilators · 5 1/4" long

4644



4644 TANK CAR · Four-wheeled · A model of the German Federal Railways standard tank car with lettering for "BP" · Tank and filler caps green · Black ladders and underframe · Platform with handrails at one end · 4 in. long

4645



4645 TANK CAR · Four-wheeled · A model of the standard tank car used by EVA (Eisenbahn-Verkehrsmittel-Aktiengesellschaft) lettered "TOTAL" · Grey body · Ladders and walkways black · Platform, railings and underframe black · 4 in. long

4646



4646 TANK CAR · A model of the standard four-wheeled tank car lettered "ARAL" · Tank and filler caps blue · Walkway and ladder, also underframe with platform and handrails, black · 4 in. long

4648



4648 TANK CAR · Eight-wheeled · Scale tank body white, with lettered "GASOLIN" · Walkways, ladders and underframe black · Length 6 1/2"

4649



4649 TANK CAR · Eight-wheeled · Scale tank body red, with lettering "AVIA" · Walkways, ladder and underframe black · Length 6 1/2"

4663

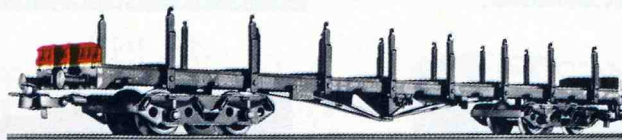

4663 FLAT CAR · Eight-wheeled · A model of the German Federal Railways Type SS1mas 53 Die cast metal body, black with brown end sills · Side stanchions fold down · Length 9"

-for children as well as adults-



and Uncoupling (RELEX)

new 4660



The sides can be opened by remote control using the 5112 uncoupling track (see page 42) and 2197 (see page 48).

4656



4658



4660 BEER REFRIGERATOR CAR · 4 wheeled · Model of the private car of Kulmbacher Mönchs-hof-Bräu · Blue · White lettering · Silver roof with imitation ventilators · 5 1/4" long

4656 BULK GOODS CAR · A Model of the Belgian State Railways (SNCB) four-wheeled 1000 G-1 Type car · Brown · 4" long

4658 CONTAINER CAR FOR FINE BULK GOODS · A model of the German Federal Railways four-wheeled Type Kds 54 car in use as a private wagon of the Franken Sugar Co. (Franken-Zucker) · Silver containers with blue center parts, black underframe · 4" long

4550



4657

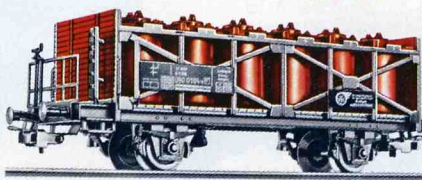

4659



4550 BOX CAR · Italian State Railways (FS) Type · Four-wheeled · Removable roof · Silver body, grey roof · 4 1/2" long

4657 ACID CONTAINER CAR · Model of the two axle VTG design acid carrying car of the German Federal Railways · 12 scale model plastic acid containers · Platform with ladder and railing at one end · Containers are brown, frame and sides black · Length 4 1/2"

4659 CONTAINER CAR · Model of the two axle container carrier car, Type Berlin, on the German Federal Railways · Has two removable containers marked Hapag-Lloyd · Containers silver with black underframe · 6 1/8" long

MARKLIN-HAMO WHEEL SETS for two rail operation

7588 SET OF WHEELS, consisting of four axles · For converting all 4600 stock (except 4611, 4617, 4618, 4631, 4633, 4635, 4644, 4645, 4646, 4656, 4657, 4659 and all eight-wheeled cars) to the D.C. two-rail system

7588

7587 SET OF WHEELS, consisting of three axles · For converting wagons 4611, 4617 and 4618 (page 36) to the D.C. two-rail system

7587

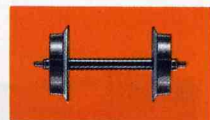

American Freight Cars with Automatic Coupling and Uncoupling (RELEX)



4571

4575



4571 WESTERN PACIFIC BOX CAR · A model of the Western Pacific Railroads eight-wheeled, 50 ton box car · Silver body with orange and black lettering Roofwalk mounted on roof · Both doors open · 8 1/8" long

4575 GONDOLA · A model of the Louisville and Nashville Railroads "Dixie" Line gondola · Trucks with movable bolsters · Brown plastic body with white lettering · 8 in. long

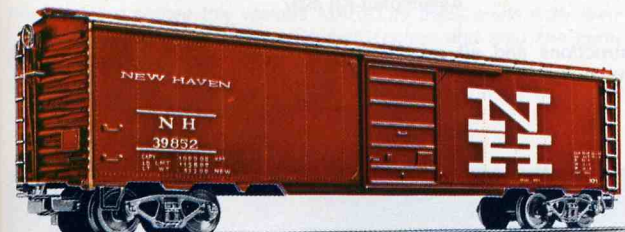

4573



4570

4573 NEW HAVEN BOX CAR · A model of the New Haven Railroads eight-wheeled 50 ton box car · Tuscan Red with white lettering · Roofwalk mounted on roof · Both doors open · 8 1/8" long

4570 CABOOSE · A model of the Santa Fé Railroad standard caboose · Eight-wheeled · Red body with white lettering · Silver roof with roofwalks · 6" long

4576

new



4576 CABOOSE · Four-wheeled · Penncentral prototype with end platforms and ladders · Light brown body with silver roof · 3 1/8"

MARKLIN

MÄRKLIN Car Kits

DEPRESSED CENTER FLAT CAR KIT **4917**

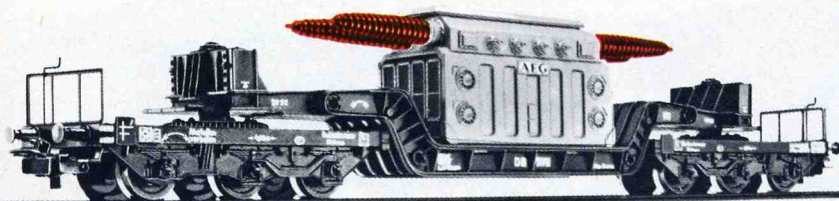

Assembled Kit 4917

WRECKING CRANE KIT **4912**

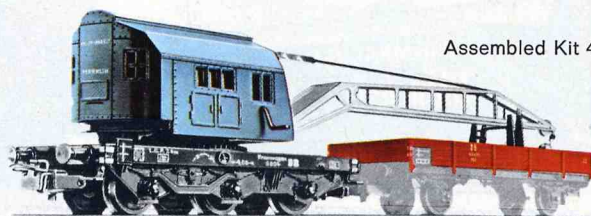

Assembled Kit 4912

4904 GONDOLA CAR KIT



Assembled Kit 4904

BOX CAR KIT **4950**



Assembled Kit 4950

REFRIGERATOR CAR KIT **4918**

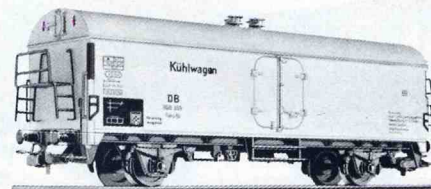

Assembled Kit 4918

GONDOLA CAR KIT **4902**



Assembled Kit 4902

TANK CAR KIT **4921**

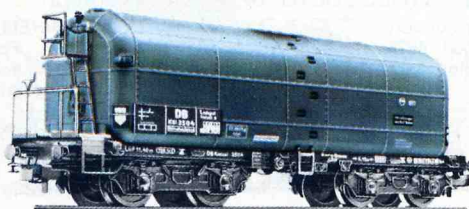

Assembled Kit 4921

SLIDING ROOF CAR KIT **4919**



Assembled Kit 4919

BEER REFRIGERATOR CAR KIT **4934**



Assembled Kit 4934

PASSENGER COACH KIT **4802**

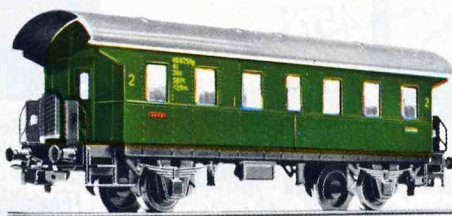

Assembled Kit 4802

BOX CAR KIT **4937**



Assembled Kit 4937

The cars illustrated can be built from these kits. Each kit includes complete illustrated instructions and all cars feature the automatic couplers (RELEX). The only tools required are a pair of pliers and a screw driver. When building Kit 4902 you will also need a hammer.

**- for leisure
time and
for play -
MÄRKLIN**





MÄRKLIN-M-Track (M=Metal) for a Trouble Free Layout

One reason for the success of MÄRKLIN in model railroading is the simplicity, durability and versatility of the track. Our proven metal track features the most reliable current distribution system ever devised. Stud contacts project from the center of the ties. Current is picked up by the sliding current collector on the underside of the locomotive.

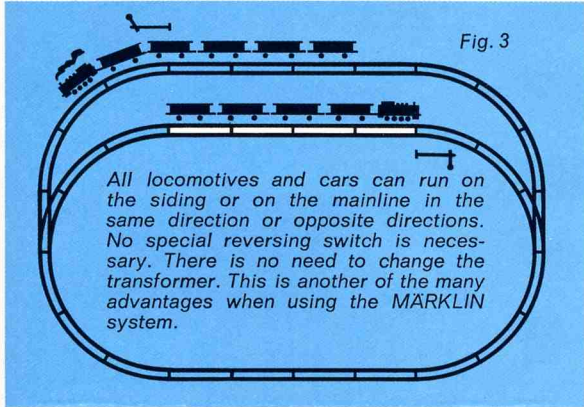

All locomotives and cars can run on the siding or on the mainline in the same direction or opposite directions. No special reversing switch is necessary. There is no need to change the transformer. This is another of the many advantages when using the MÄRKLIN system.

Fig. 1

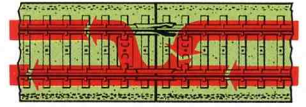

Accurately formed black rails are securely mounted on a sturdy metal roadbed, finished to resemble rock ballast. Rail-end joiners push together and pull apart easily for repeated use.

Center stud contact tongues lock together for excellent electrical contact, at the same time as the railjoiners go together. This not only assures a most reliable electrical connection, typical of the MÄRKLIN system, but in addition helps to hold the track sections together tightly.

Three track ovals are available, with varying diameters. The smallest oval, for branches and industrial sidings, consists of 8 sections of 5120, measuring 24" in diameter.

The medium oval, consisting of 12 sections of 5100, measures 30" in diameter. All of the related track items, turnouts, crossings, as well as the straight sections belong to the series with numbers beginning with 51.

A special feature of the MÄRKLIN track is the EXCELLENT CURRENT FEEDING QUALITIES. Even when the rail joiners are bent, as is likely to happen after much use, there is no problem of the current being fed as the other rail joiner will still carry the electrical current. No soldering is ever needed to connect your railroad (Fig. 1).

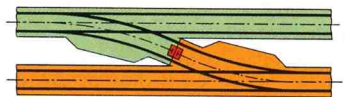

Fig. 2

It is easy to insulate one section of track from another. Simply slip a 5022 insulator piece (see page 44) or any piece of paper, between the center track tongues. NO SPECIAL SECTION OF TRACK IS NEEDED (Fig. 2).

The outer oval with 12 sections of 5200 is 36" in diameter. The track sections, turnouts crossings, etc. that belong to this series begin with the number 52 (see comparisons below mentioned).

The screws needed for mounting the track when using 7171 sound deadening strips (see page 47) are included in the package. When not using the sound deadening strips we recommend using flat head screws (No. 7299 see page 42).



How the Different MÄRKLIN Track Circles Compare

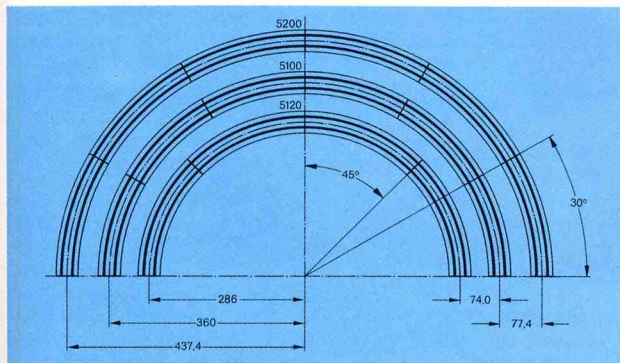

This drawing shows the various MÄRKLIN track ovals with their radius dimension, track intervals and angles, and also the number of sections required for full or partial circles.

- 1 circle of 5200 = 12 sections
- 1 circle of 5100 = 12 sections
- 1 circle of 5120 = 8 sections

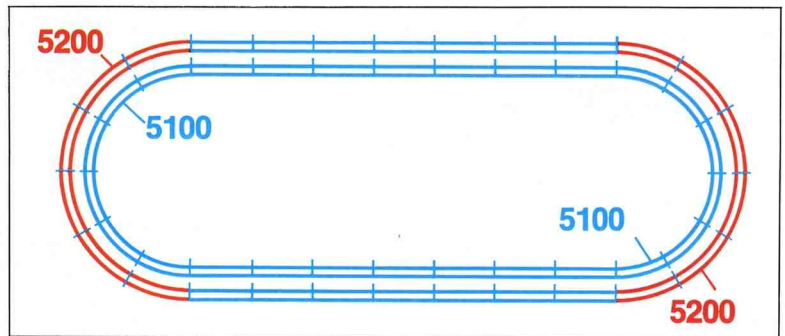

Track sections of the 5200 Series are for extending an existing system already made up of 5100 Series track. They enable concentric circles to be laid with a track center spacing of 3", and thus provide a safe operating distance between the two tracks of 1 1/2". The 5202 turnouts are used to cross from the inner to the outer loop. The construction of the 5200 track is the same as the 5100 M-track.

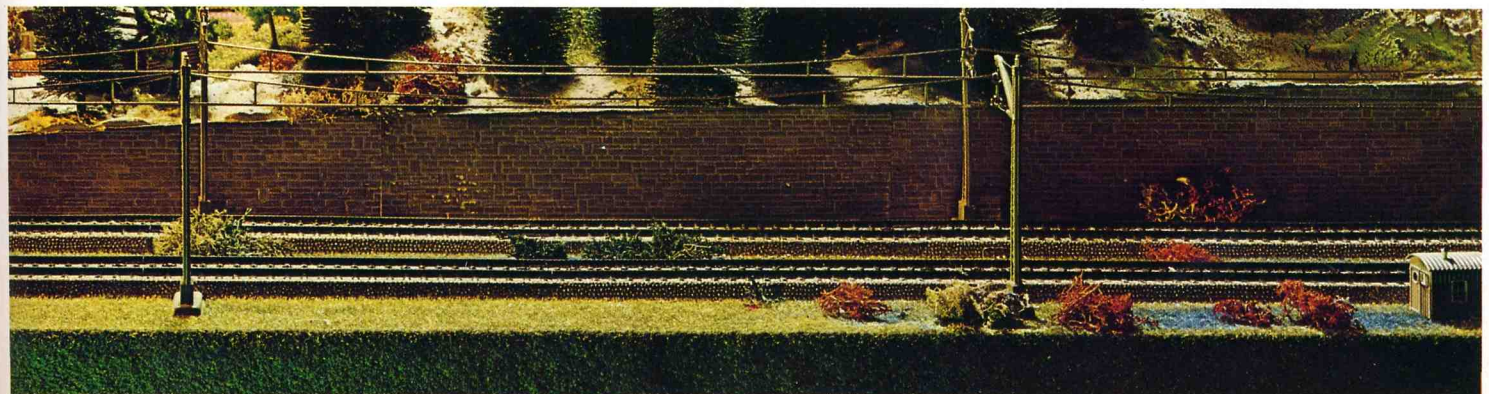

MÄRKLIN-M-Track for a Trouble Free Layout

Curve Track Sections 5100

12 5100 Track Sections for standard curve make a circle with a 30" outside diameter.



Full length = 30°



Half length = 15°



1/4 length = 7° 30'

Feeder track

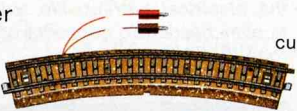

curved

Full length = 30°
2 connecting cables

Contact track section

Like the other track contact sections, these are used to operate automatically the impulse operated accessories such as turnouts, points, and signals. A small cam located in the center of the roadbed is actuated by the pickup shoe on locomotives and cars. There are two connecting sockets, one which is operated in each direction of travel of the train, so that you can have two different functions on each contact track section.



Contact track section curved
Half length = 15°

Contact track



curved

Full length = 30°

Small radius track for branchline and industrial tracks



5120

CURVED TRACK SECTION · Full length = 45° · Branch lines and industrial sidings with small radius curves can be built using this track · 8 sections form a complete 24 inch diameter circle · Large locomotives such as 3047 and the express passenger coaches will negotiate this radius, however if you have reverse curves at least on full length section should be placed between the curve · The 5120 track sections can be used with the 5100 and 5200 sections so that a great variety of layouts can be designed

Straight Track Sections

5106



Full length = 7"

5107



Half length = 3 1/2"

5129

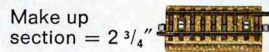

Make up section = 2 3/4"

5108

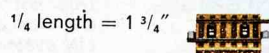

1/4 length = 1 3/4"

5109

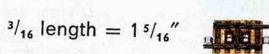

3/16 length = 1 5/16"

5110

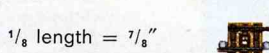

1/8 length = 7/8"

Straight feeder track

Full length = 7"

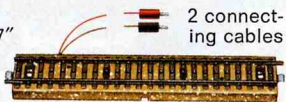

2 connecting cables

5111

Contact track section

5146



Straight · Half length = 3 1/2"

Contact track section

5105



Straight · Full length = 7"

5114



CROSSING · Length 7 3/5" = 30° · The center studs of the two crossing tracks are insulated electrically from each other

7190



7190 TRACK END BUMPER · Die cast metal buffer beam · 2 3/4" long

Curve Track Sections 5200

12 5200 track sections make a circle with a 36" outside diameter.



Full length = 30°



Length = 24° 17'

Matches curved track section of 5202 Turnout



Half length = 15°



Length = 5° 43'

This section used with 5206 equals length of 5200

Contact track section



5213

CONTACT TRACK, curved · For outside radius · Half length = 15° · Construction and operation is the same as for 5146/5147

STRAIGHT MAKE UP SECTION · Length 5/16" long



5208

STRAIGHT MAKE UP SECTION · 5/8" long



5210



5211

CROSSING · Frog angle 48 1/2° · 3 7/8" long · The center studs of the crossing tracks are insulated electrically from each other

TRACK SCREWS for mounting metal track · Package of 200 screws

new
7299

Track End Bumpers



7191

7191 TRACK END BUMPER · With working signal light · Die cast metal buffer beam · 2 3/4" long



Raising the track ramp releases the couplers.

The RELEX is designed to provide "delayed action uncoupling". This permits you to push the cars after uncoupling without the couplers closing again.

Train operations become quite realistic, when you do not have to uncouple the cars and locomotives by hand. This can be done automatically using the uncoupling track section, along with the uncoupler light which adds greatly to the scenic effect. When the car is near the uncoupler light, a press of the control panel button will open the coupling leaving it standing from the rest of the train. Cars with the RELEX delayed action uncoupler can then be pushed by the locomotive without the couplers reengaging. By using this system a most realistic yard operation can be duplicated.

Remote Control Automatic Uncoupling

5113 UNCOUPLER LIGHT STANDARD · Die cast metal · The light on the top of the standard lights up when the uncoupler track is energized · 3 3/8" high

5113

5112

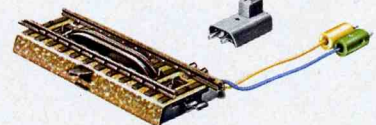

5112 UNCOUPLING TRACK SECTION · For releasing the automatic couplers on cars and locomotives · Ramps raise on either side of the center track studs, operated electrically by remote control from the control panel or manually by the lever on the side of the roadbed · Two connecting cables · Length 3 1/2" long



The MÄRKLIN-M-Turnouts and how to use them

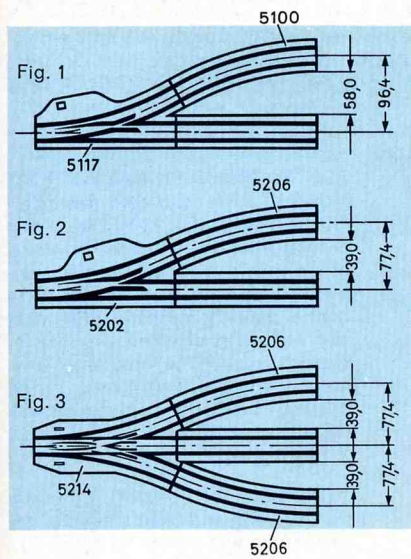

When laying out sidings parallel to the main line using 5117 and 5121 (Fig. 1) turnouts, use 5100 curve track for the reverse curve to obtain track center spacing of $3\frac{1}{8}$ ". With 5202 (Fig. 2) and 5214 (Fig. 3) turnouts, use 5206 for the reverse curve to obtain track center spacing of 3". The illustration below shows some of the ways turnouts and track sections may be combined.

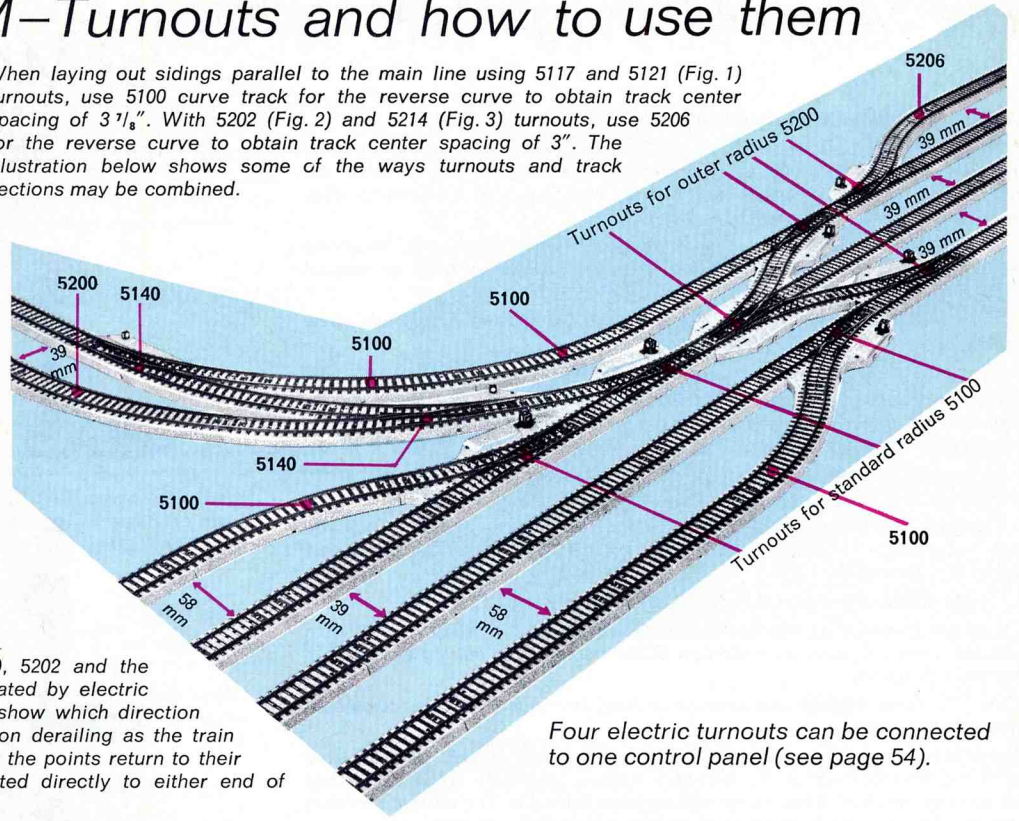

The electric remote control turnouts 5117, 5140, 5202 and the double slip switches 5128 and 5207 are all operated by electric double solenoids, with working signal lamps to show which direction the points are set at all times. The points are non derailing as the train pushes the point aside and after the train passes the points return to their original setting. Extra turnouts can be connected directly to either end of other turnouts, giving you a big savings in space.

Four electric turnouts can be connected to one control panel (see page 54).

MÄRKLIN-M-Turnouts 5100

Electric Turnouts for remote control operation

5128 **5117** **5140**

5128 DOUBLE SLIP SWITCH · 30° crossing angle · Electric double solenoid · Working signal lamp shows whether set for crossing or diverging tracks · Hand lever for manual operation · The straight tracks are $7\frac{1}{16}$ " long, and the curved tracks are $7\frac{1}{2}$ " long

5117 PAIR OF ELECTRIC REMOTE CONTROL OPERATION · One right hand, one left hand, both with double solenoids · Working signal lamps · Spring operated points · The track lengths are the same as 5100 and 5106

5140 ELECTRIC REMOTE CONTROL CURVED TURNOUTS · One right hand, one left hand with double solenoid · Working signal lamps · Spring operated points · Length and radius of the inner curve is the same as 5100 · The length of the outer curve is $10\frac{1}{2}$ " long · Installation instructions are included with each pair

Turnouts for manual operation

5121

5121 PAIR OF MANUAL TURNOUTS · With hand lever and sprung points · Lengths of the track sections are the same as 5117

with electric solenoids for automatic operation

5128

5128 DOUBLE SLIP SWITCH · 30° crossing angle · Electric double solenoid · Working signal lamp shows whether set for crossing or diverging tracks · Hand lever for manual operation · The straight tracks are $7\frac{1}{16}$ " long, and the curved tracks are $7\frac{1}{2}$ " long

5140

5140 ELECTRIC REMOTE CONTROL CURVED TURNOUTS · One right hand, one left hand with double solenoid · Working signal lamps · Spring operated points · Length and radius of the inner curve is the same as 5100 · The length of the outer curve is $10\frac{1}{2}$ " long · Installation instructions are included with each pair

The curved turnouts provide cross-over facilities on curves, between inner and outer circles, while keeping regular three inch center spacing between tracks.

MÄRKLIN-M-Turnouts 5200

5214

5214 THREE WAY TURNOUT, with electric double solenoids · Two hand levers for setting the points manually · Five connecting cables · The length of the straight track section is 7 inches and the radius of the curved sections is 18" · When used with the 5206 track sections the 3" track center spacing can be maintained (see Fig. 3, above mentioned)

5202

5202 PAIR OF ELECTRIC REMOTE CONTROL TURNOUTS · One right hand and one left hand, both with double solenoids · Working signal lamps · The length of the curve track is $\frac{5}{16}$ " the length of 5200

5207

5207 DOUBLE SLIP SWITCH · When used with the 5202 Turnouts the 3" track center spacing can be maintained · With double solenoid · Hand lever is 7 " long · Two 5208 make up track sections, each $\frac{5}{16}$ " long, are included

The MÄRKLIN Signal Assortment for MÄRKLIN-M-Track

Automatic Train Control Home Signals are designed to . . .

. . . automatically start and stop trains. The track is dead when the signal is red. Two built in ON-OFF track power switches control this whether the signal is operated by remote control from the panel, by the moving train with contact tracks, or operated manually.

. . . install without tools; no other equipment needed. The metal mounting plate locks under the track roadbed of straight and curved track to connect "ground."

. . . use the 7072 control panel (7072 see page 54) and the button will show which direction the signal is set.

. . . have built in color coded wiring. Match the colored plugs to the like colored sockets of the control panel. Slip the red wire connectors to the center track tongues before and after the insulation points. Simple illustrated instructions included with each signal.

. . . control trains operating from the catenary system. Feeder mast plugs into the signal; use insulator contact wire. No other equipment needed.

. . . provide you with an automatic, accident free operating layout. Thus you can operate several trains. And the colored lights add greatly to the scenic effect of your layout.

. . . offer completely prototype signaling including warning signals.

These are installed as the home signals and connect directly to the home signals. Thus you have an indication of the home signal setting even if it is behind a building.

One 7072 control panel can operate at least four home signals, connected with warning signals.

These home signals can all be used for automatic train control, whether used with the stud contact or the catenary system. The 7041 home signal has three coils, while all other home signals have two coils. The current switches can handle heavy loads because of their durable silver contacts.

The connecting wires have color coded plugs with side sockets, thus allowing extra plugs to be inserted. Sockets are incorporated into the signal base for connection to the catenary system and for "ground" connections. The masts are high detailed die cast metal. Scale lighting is provided by special bulbs. Track insulators, a base plate, and illustrated instructions are included.

Warning Signals without train control



7036

7036 WARNING SIGNAL WITHOUT MOVING ARM with disc movable · Double solenoid · Signal lights change from amber/amber to green/green · Two blue cables for automatic operation · Connection to control panel or for working together with home signal · Yellow cable for current supply · The three plugs (red, green, and yellow) have cross-sockets · For use in conjunction with the 7039 home signal · 1 1/8" wide, 2 5/8" long and 2 7/8" high



7037

7037 WARNING SIGNAL with extra movable arm and fixed disc · Operation, lights and cables as No. 7036 · Lights change from amber/amber to amber/amber/green · For use in conjunction with the 7040 home signal · 1 1/8" wide, 2 5/8" long, 2 7/8" high



7038

7038 WARNING SIGNAL with extra arm and disc both movable · Two double solenoids · Signal lights change either as No. 7036 or 7037 · Three blue cables with red, green and orange cross-plugs · Current supplied by yellow cable with yellow cross-plug · Used mostly in conjunction with the 7041 home signal · 1 1/8" wide, 2 5/8" long, and 2 7/8" high

Signals for Automatic Train Control



7039

7040

7041



7187

7188 7042

for Rail and Catenary

7039 HOME SIGNAL with one semaphore arm and signal light changing from red to green · 1 1/8 in. wide, 2 3/4 in. long and 5 in. high

7040 HOME SIGNAL with two coupled semaphore arms and signal lights changing from red to green/amber · 1 1/8" wide, 2 3/4" long and 5" high

7187 COLOR LIGHT DISTANT SIGNAL · For use only in conjunction with the 7188 color-light home signal · Signal lights change from green/green to amber/amber by four bulbs in all · 5/8" wide, 7/16" long, 2 3/8" high

7041 HOME SIGNAL with two independently working semaphore arms · The operation is the same as other train control signals, but in addition a third solenoid with an additional blue cable with orange plug allows three separate signal indications · Signal lights change from red to green or from red to green/amber · 1 1/8" wide, 3 7/8" long and 5" high

new
7339

7339 LIGHT HOME SIGNAL · Lights change from red (stop) to green (proceed) by manual operation and control the current to the center stud of the piece of track connected to the signal · An additional piece of track 3 1/2" long, with interrupted center studs, is included · Length: 3 1/2", width 2 1/4", height 3 1/2"

7188 COLOR LIGHT HOME SIGNAL · Two signal lights change from red to green, with automatic train control · Hand lever for manual operation · Pair of sockets for connection with the 7187 Distant Signal · 1 1/8" wide, 2 3/4" long and 3 1/2" high

7045

7042 YARD AND SIDING SIGNAL · With lighted moving signal disc · For stopping and starting trains in sidings and yards · 1 1/8" wide, 2 3/4" long and 2 3/4" high

7045 UNIVERSAL REMOTE CONTROL SWITCH · Can be used for turning lighting current or train current on and off · Can be controlled by the control panel, by contact tracks or by the hand lever · The many functions of this unit, such as turning on and off station lights by passing trains, or overriding certain train control signals is fully covered in our signal manual

5004

5004 CONNECTING CABLE for center track tongue connection · 30" long

5015

5015 INSULATION MARKER for identifying insulation points

5022 CENTER TRACK TONGUE INSULATOR · For insulating five track joints

5022



The MÄRKLIN-Catenary for MÄRKLIN-M-Track

The electric locomotives can pick up their current from the over head contact wires with the same reliability as from the track stud contacts. The lever on the locomotives changes over the pickup from the bottom shoe to the pantograph. With the Märklin system it makes no difference in which direction the locomotive is placed on the track. For maximum operation it is advisable to connect the catenary system to a separate transformer. This will allow you to run two locomotives on the same track under independent control.

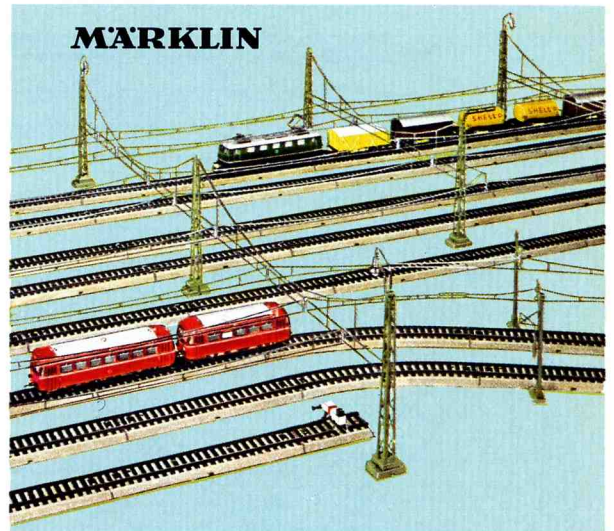

Additional Parts for Catenary System

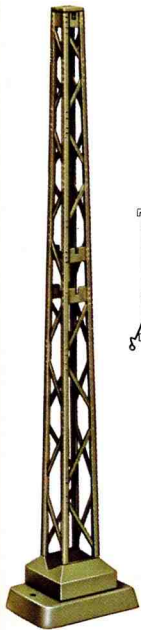

7006

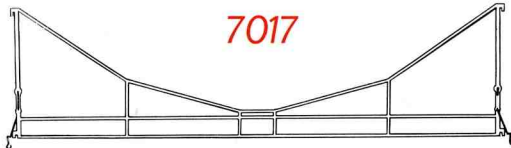

7017

7017 CROSS SPAN to hold catenary wires · Clips to tower masts to span up to three parallel tracks · 11" long

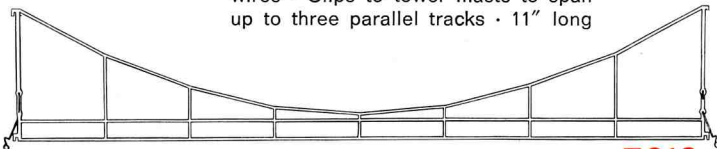

7016

7016 CROSS SPAN to hold catenary wires · Clips to tower masts to span up to four parallel tracks · 15 1/2" long

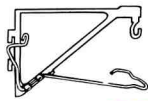

7025

7025 CANTILEVER SUPPORT ARM · Clips to the side of the tower mast to provide support for contact wires over single track passing on the outside of tower masts

7021

7021 TOWER MAST, plastic · Base 1" x 1 1/4" · 7 1/2" high · For tower mast with lights see page 56

7006 CROSS SPAN INSULATOR for mounting contact wires on cross spans · One required for each connection above each track · Illustration full size

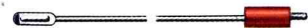

7003

7003 FEEDER CABLE for supplying current to any point of the catenary system, especially in conjunction with tower masts · 24" long

7004 7005

7004 FASTENING KIT · Contains: 5 screws, 5 nuts and 5 washers · For use where ever two overhead wire sections meet, where there is no mast

7005 CATENARY SET FOR SIGNALS · Contains: 2 signal masts 7012, 2 insulator pieces 7022 and 2 contact wires 7014 · For use with home signals of the series 7000 for automatic train control

Component Parts for Catenary System

7009 CATENARY MAST · Basic support · 4 3/8" high

7010 FEEDER MAST · For supplying current to contact wires · With two cables · Instructions for building catenary system · 4 3/8" high

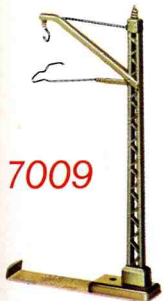

7009

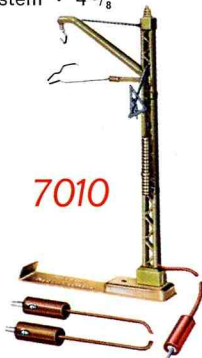

7010



7012

7012 FEEDER MAST FOR SIGNALS, with 1 cable · 4 3/8" high

7011

7011 BRIDGE MAST, with mounting bracket · For metal bridges only · 4 3/8" high

7013



7023



7015



7014



7022



7018

7020



7019

7013 CONTACT WIRE SECTION with slide together connections at each end, for straight and curve track and for use over turnouts · 9 1/2" long

7277



7277 CONTACT WIRE SECTION FOR CROSSINGS 5114, 5128, 5207, and 5211

7014 CONTACT WIRE SECTION with slide connection · 4 1/2" long

7015 CONTACT WIRE SECTION with slide connection · 4 1/2" long

7018 CONTACT WIRE SECTION for straight and curved track · 10 3/4" long

7019 CONTACT WIRE SECTION for straight track only · 14 1/2" long

7020 SIMULATED WIRE TENSIONER · Clips to side of catenary masts for scenic effect

7022 INSULATOR SECTION CONTACT WIRE for interrupting current · With slide connection · 4 1/2" long

7023 MAKE-UP CONTACT WIRE SECTION, with slide connections at each end · 4" long

The overhead contact wires, with their tensioning and cross span connections, are designed exactly as on the prototypes. This is why the MÄRKLIN catenary system appears so realistic, both on single tracks and where cross spans are used over yards.

The catenary masts are of durable, flexible plastic, and are rugged and durable.





The spring contact wire holders assure a reliable contact at all times and maintains a constant voltage.

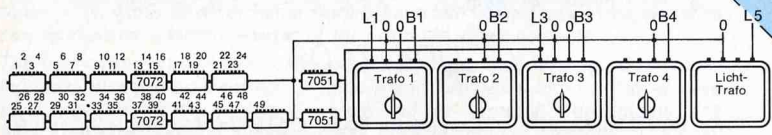
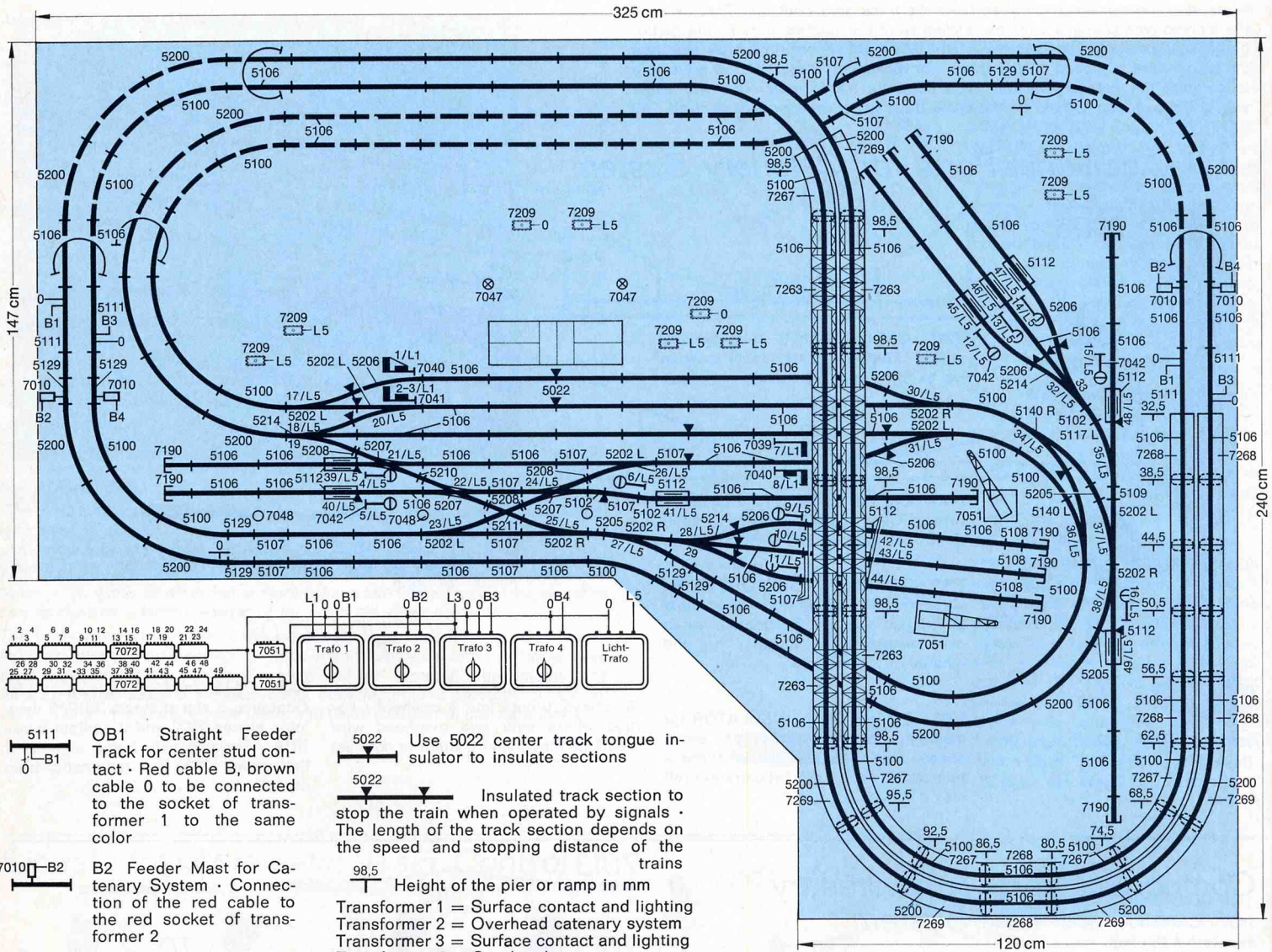

Telescoping contact wires 7013 and 7023 adjust to any track dimension. Because of their flexibility, they fit any curve accurately, without any auxiliary equipment. The longest contact wire 7019 has been designed for use on long straight aways.

Using the tower mast 7021 and cross spans 7016 any width of track can be spanned. You need 2 masts and one cross span for the first four tracks and one mast and one span for each additional four tracks. The cantilever support arm 7025 can be installed for single tracks next to the tower masts.

Trackplan for MÄRKLIN H0 layout on the pages 15, 17, 19, 21, 23, 25, 29, 31, 33, 34, 38, 46, and 57



-  OB1 Straight Feeder Track for center stud contact · Red cable B, brown cable 0 to be connected to the socket of transformer 1 to the same color
-  B2 Feeder Mast for Catenary System · Connection of the red cable to the red socket of transformer 2
-  3 Blue cable with green plug for connection to the green socket · Blue cable with red plug for connection to the red socket of the pair of sockets on the control panel (7072), which is marked for example "3"
-  L5 Yellow cable for connection to socket L for lighting to transformer 5 or to the distributor panel 7209—L5, which is connected to the transformer

-  Use 5022 center track tongue insulator to insulate sections
-  Insulated track section to stop the train when operated by signals · The length of the track section depends on the speed and stopping distance of the trains
-  98,5 Height of the pier or ramp in mm
- Transformer 1 = Surface contact and lighting
- Transformer 2 = Overhead catenary system
- Transformer 3 = Surface contact and lighting
- Transformer 4 = Overhead catenary system
- Transformer 5 = Lighting

List of parts

For this layout the following parts are required:

34 — 5100	4 — 5202	11 — 7012	11 — 7042	7 — 7267	2 — 7114
3 — 5102	2 — 5202 L	7 — 7013	4 — 7046	12 — 7268	80 — 7115
128 — 5106	3 — 5205	51 — 7014	2 — 7047	7 — 7269	45 — 7121
15 — 5107	7 — 5206	42 — 7015	3 — 7048	3 — 7277	60 — 7122
3 — 5108	3 — 5207	5 — 7016	2 — 7051	24 — 7511	55 — 7123
1 — 5109	1 — 5210	31 — 7018	13 — 7072	20 — 7000	2 — 7124
4 — 5111	1 — 5211	55 — 7019	11 — 7190	12 — 7101	110 — 7125
11 — 5112	3 — 5214	6 — 7021	10 — 7209	2 — 7102	20 — 7131
11 — 5113	12 — 7003	19 — 7022	32 — 7250	5 — 7103	15 — 7132
1 — 5117 L	15 — 7004	68 — 7023	2 — 7251	6 — 7105	10 — 7135
12 — 5129	30 — 7006	1 — 7039	50 — 7252	45 — 7111	5 trans-
1 — 5140	80 — 7009	2 — 7040	70 — 7253	50 — 7112	formers
29 — 5200	4 — 7010	1 — 7041	8 — 7263	60 — 7113	(30 VA)



M Track-Extension-Packs

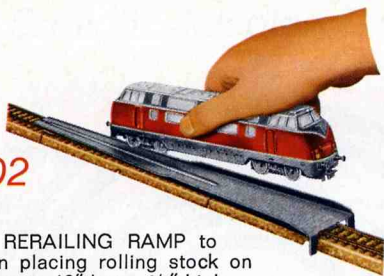

7002

7002 RERAILING RAMP to help in placing rolling stock on the layout · 12" long · 3/4" high

0206 TRACK PLANNING TEMPLATE · Transparent plastic · An indispensable aid for designing track plans · 1:10 scale covers all track sections for the series 5100/5200



0206

7171



7171 SOUND DEADENING RUBBER STRIPS · 50 pieces with 50 flat head wood screws · The rubber strips hold the track above the train board · A hollow shoulder extends through

the track screw hole to insulate the screw head · Slim flat head screws hold the track firmly to the board · Instructions supplied also show how to mount turnouts, points, and crossings · Catenary masts lock under the roadbed without screws · Test have shown that the noise of running trains on plywood is reduced 50%, with these sound deadening strips

0321



MÄRKLIN HO TRACK PLANS FOR M-TRACK 5100 AND 5200



0351 ADVANCED MÄRKLIN HO TRACK PLANS FOR M-TRACK 5100 AND 5200



0341 MÄRKLIN SIGNAL MANUAL FOR M-TRACK

For information on these booklets see page 55.

Basic HO Gauge Track Layouts for M-Track

M

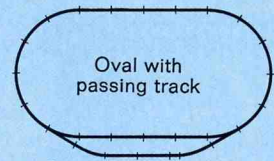

Oval with passing track

Size 58 1/4 by 33 1/2 in.

Track sections: Eleven 5100, 1—5103, 10—5106, 1—5108, 1 pair of 5117 or 5121 points

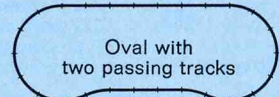

Oval with two passing tracks

Size 80 7/10 by 33 2/3 in.

Track sections: Eleven 5100, 1—5103, 18—5106, 4—5206, 2—5214

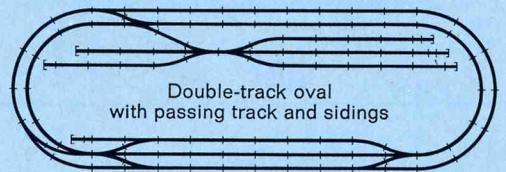

Double-track oval with passing track and sidings

Size 107 by 36 1/8 in.

Track sections: Eleven 5100, 1—5103, 61—5106, 1—5107, 3—5108, 1—5111, 1—5140, 10—5200, 2—5202, 4—5206, 1—5207, 4—5214

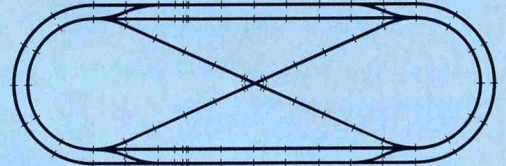

Double-track oval with double reversing loop
Size 106 3/10 by 36 1/8 in.

Track sections: Eleven 5100, 1—5103, 43—5106, 4—5107, 4—5108, 4—5110, 1—5111, 12—5200, 2—5202, 4—5208, 4—5210, 1—5211, 4—5214

Track-Extension-Packs

M

5090

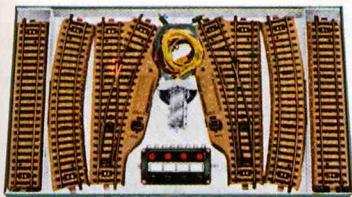

5090 TRACK EXTENSION PACK for extending track oval · Contains: 10 straight tracks 5106, 1 pair of electric turnouts 5202, 2 curve track 5206, 1 control panel 7072, 1 distributor panel 7209, 2 wood screws 78612 and two connecting cables · Instructions for turnouts and track plans are included

5091

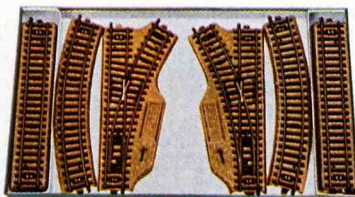

5091 TRACK EXTENSION PACK for extending an oval track · Contains: 2 curved track 5100, 10 straight track 5106, 1 pair of manual turnouts 5121 and an instruction booklet with track plans

The 5090, 5091 and 5092 track packs can be used to extend the track ovals supplied with train sets 2940—2959, 2960—2979, 3121, 3200 and 3203.

Examples of how the extension pack can be used to extend the train sets 2940—2959, 2960—2979, 3121, 3200 and 3203.

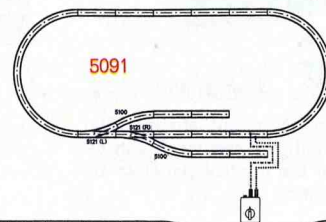
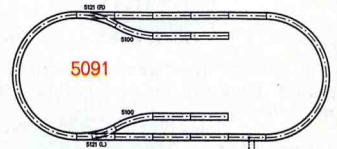

5092 **new**



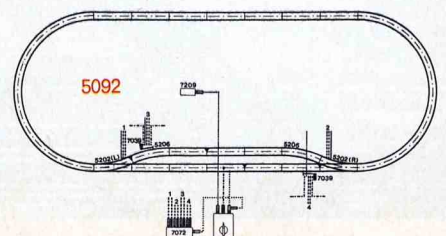
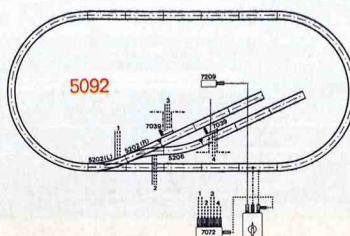
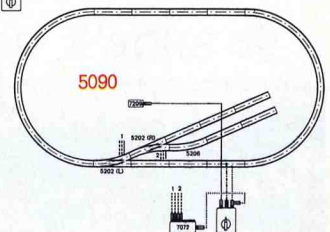
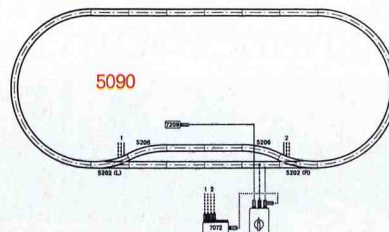
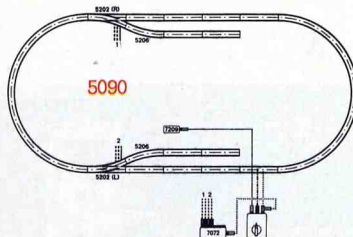

5092 TRACK EXTENSION PACK to extend a track oval · Contains: 13 straight track 5106, 1 pair electrical turnouts 5202, 2 curve track 5206, 2 home signals 7039, 1 control panel 7072, 1 distributor panel 7209 and five extension cables · Screws for mounting the control panel · With instruction booklet

The pack 5092 contains **signals** to make the layout operation more interesting.

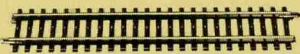
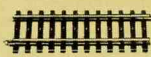

MÄRKLIN-K-Track 2100 (K=Plastic)

Straight Track Sections

-  **2100**
Full length = 7"
-  **2101**
Half length = 3 1/2"
-  **2102**
1/4 length = 1 3/4"
-  **2104**
1/8 length = 7/8"

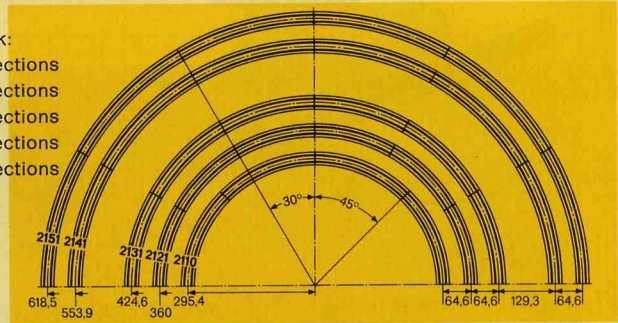

The five circles of MÄRKLIN-K-Track:

- 1 Industrial circle 2110 = 8 full sections
- 1 Standard radius I 2121 = 12 full sections
- 1 Standard radius II 2131 = 12 full sections
- 1 Wide radius I 2141 = 12 full sections
- 1 Wide radius II 2151 = 12 full sections

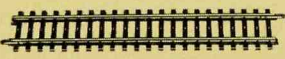
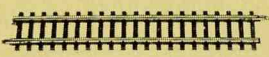

The MÄRKLIN-K-Track 2100 uses the same stud contact system as described, with its advantages, on page 41. Both running rails are mounted on highly detailed plastic ties. The stud contacts, barely visible, project through the ties from below, and when used with the pickup shoe on the locomotive assure an extremely reliable current pickup system. The rails are connected by rail joiners, stud contact connectors, plus a snap coupling of the plastic tie strip. To fasten the K-track to the board use MÄRKLIN track screws (see No. 7599, page 49).

Equalizing Straight Track

-  **2106**
6 5/8" long
-  **2107**
6" long
-  **2108**
1 1/2" long

Curved Track Sections

12" Radius Industrial circle

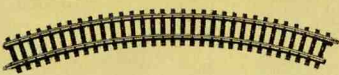
-  **2110**
Full length = 45°

17" Radius Standard Radius II

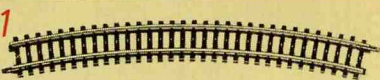
-  **2131**
Full length = 30°

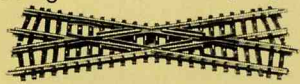

Crossing • 22° 30' crossing angle

-  **2159**
Straight section 6 5/8" long

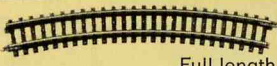
15" Radius Standard Radius I

-  **2121**
Full length = 30°

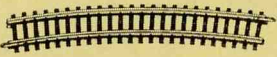
3/4 length = 22° 30'

-  **2132**
-  **2133**
1/2 length = 15°

Straight Feeder Track

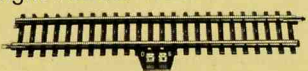
-  **2190**
Full length = 7" • With two connecting clips, marked "O" and "B"

2123
Half length = 15°

2134
1/4 length = 7° 30'

2124
1/4 length = 7° 30'

2135
1/8 length = 3° 45'

Straight Contact Track

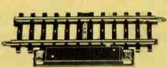
-  **2199**
Half length = 3 1/2"

Curved Contact Track

-  **2129**
Half length = 15°
15" radius

Curved Contact Track

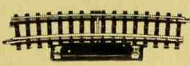
-  **2139**
Half length = 15°
17" radius

The contact track sections permit automatic control of all impulse operated electrical accessories such as points, signals, etc. They are activated by the pickup shoe on the locomotive. Two sets of contacts, one operating in each direction the train travels, carry different switching functions, independantly of each other.

Uncoupler Track Section

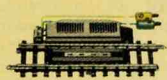
-  **2197**
Half length = 3 1/2"

Curved Track Sections

21 1/2" Radius Wide Radius I

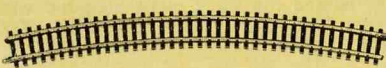
-  **2141**
Full length = 30°

24" Radius Wide Radius II

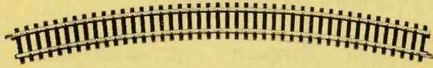
-  **2151**
Full length = 30°

For automatic uncoupling of rolling stock • The uncoupling ramp in the center of the track can be operated electrically from the control panel or by hand with the lever on the side





Straight Adapter Track

Track Extension Packs **K**

Full length = 7"

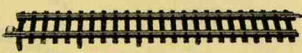

2191

For use when connecting 5100/5200 type track to 2100 type track

7504



7504 TERMINAL FOR CENTER STUD CONTACTS · This is placed at the rail joints of 2100 Series track to provide electrical insulation



7522

7522 INSULATOR FOR CENTER STUD CONTACTS · This is placed between the copper contacts of the 2100 Series track for electrical insulation

7599 new

7599 TRACK SCREWS FOR FASTENING PLASTIC TRACK · Package of 200 screws

2090



2090 TRACK EXTENSION PACK for extending oval tracks · Contains: 8 straight track 2100, 2 straight track 2107, 4 straight make-up track 2108, 2 curve track 2132, 1 pair of electric remote turnouts 2161, 1 control panel 7072, 1 distributor panel 7209, 2 mounting screws and 2 connecting cables · Complete instructions and track plans are included

2091

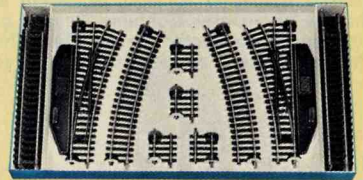

2091 TRACK EXTENSION PACK for extending oval tracks · Contains: 8 straight track 2100, 2 straight track 2107, 4 straight make-up track 2108, 2 curve track 2132, 1 pair of manual turnouts 2164 · Instruction book with track plans is included

TRACK END BUMPER



7391

In riveted steel construction design · Snaps into the rails · Black with red and white-striped buffer beam · Length 1 1/2" · Mounting screw supplied

GROUND TERMINAL



7500

Terminal for connecting the ground wire to 2100 Series track

MÄRKLIN-K-Turnouts 2100

2160 DOUBLE SLIP SWITCH · 22° 30' frog angle · 17" radius · Switch points operated electrically by double solenoid · Has hand lever for manual operation · Length of straight track section: 6 7/8" long

Double Slip Switch

2160

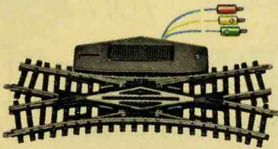

2164 MANUAL TURNOUTS (POINTS) · One right hand and one left hand for manual operation · Scale switch points · Frog angle 22° 30' · Radius of curve section: 17" · Length of straight section: 6 7/8"

Manual Turnouts

2164

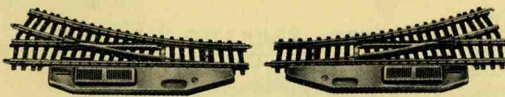

2170 THREE WAY TURNOUT with 2 electric solenoids · Two levers for setting the turnouts by hand · 6 connecting cables · Length of straight section: 6 5/8" · Angle of frog: 22° 30' · Radius of the curved sections: 17"

Three Way Turnout

2170

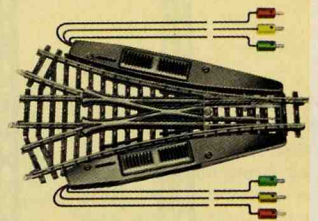

Electric Remote Control Turnouts

2161

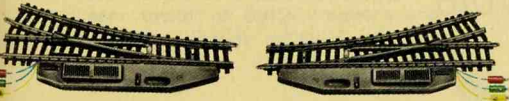

Curved Turnouts,

Electric Remote Control

2167



2161 ELECTRIC REMOTE CONTROL TURNOUTS (POINTS) · One right hand and one left hand, switch points operated by double solenoid · Scale switch points · Frog angle 22° 30' · Radius of curve section is 17" · Working indicator lights · Length of straight sections: 6 7/8"

2167 CURVED TURNOUTS, ELECTRIC REMOTE CONTROL · One right hand, one left hand operated by double solenoid · Sprung switch points · The length and curve of the track section is the same as 2121 · Length of outside curve is 9 1/2"

K - Track Extension Packs

Track Layouts for 2090 and 2091

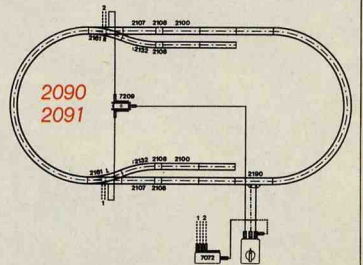
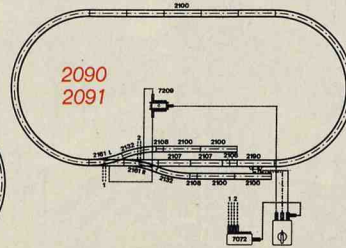
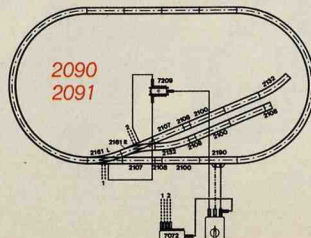
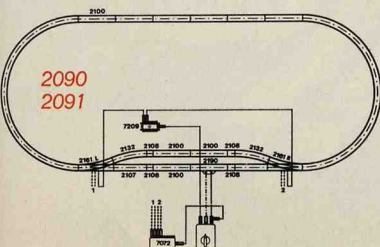

In the 2091 Track pack the electric switches 2161 shown are to be substituted with the 2164 manual switches. Also the 7072 control panel and the 7209 distributor panel are omitted.

The MÄRKLIN Catenary System 7500 for MÄRKLIN-K-Track 2100

7505

7505 CATENARY SIGNAL SET · For automatic operation of trains through the use of signals · Contains 2 signal masts 7512, 2 insulation wire sections 7022 and 2 connector wires 7014 · This mast may be used with the 7200 Series Signals · For use with 2100 Series Track

7503

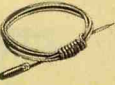

7503 CATENARY SIGNAL CONNECTING WIRE · For use when connecting the Signals to the catenary system for automatic operation of trains · Grey cable · 22" long



7509



7510



7512



7511

7509 CATENARY MAST · Basic mast for constructing a catenary system with the 2100 Series track · 3 7/8" high · With base plate for fastening to the track

7510 FEEDER MAST · For supplying power to the catenary system · Comes with connecting cables with plug · Also comes with brown cable for connecting "ground" and complete instructions for building the catenary system · Height 3 7/8" · Base plate for fastening the mast to 2100 series track

7512 SIGNAL MAST with red connection wire for connecting signals to the catenary system · Height 3 7/8" · Comes with base plate for use with 2100 Series track

7511 BRIDGE MAST · For hanging catenary wires on bridges and approaches · 3 7/8" high

7004

7004 FASTENING KIT · Contains: 5 screws, 5 nuts and 5 washers · For use where ever two overhead wire sections meet, where there is no mast



7521

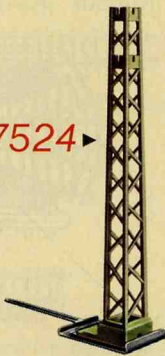

7524

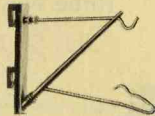

7525

7525 SUPPORT ARM for hanging single or double catenary wires in conjunction with Masts 7521 or 7524

7521 TOWER MAST · Used to hold the cross span wire supports · Comes with base plate for use with the 2100 series track · Base size 1/2" x 3/4" · Height: 6"

7524 CATENARY MAST with openings for attaching support arm 7525 · Comes with base plate for use with the 2100 series track · 3 3/4" high

7020



7020 SIMULATED WIRE TENSIONER · Clips to side of catenary masts for scenic effect

7006



7006 CROSS SPAN INSULATOR for mounting contact wired on cross spans · One required for each connection above each track · Illustration full size

Additional Parts for the Catenary System

7017

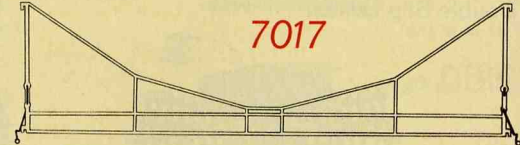

7017 CROSS SPAN to hold catenary wires · Clips to tower masts to span up to three parallel tracks · 11" long

7016

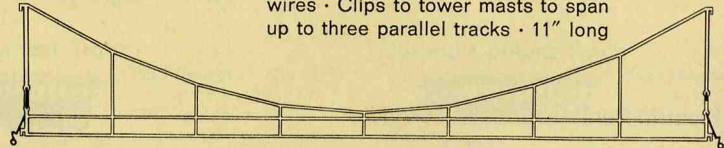

7016 CROSS SPAN to hold catenary wires · Clips to tower masts to span up to four parallel tracks · 15 1/2" long





Component Parts for the Catenary System

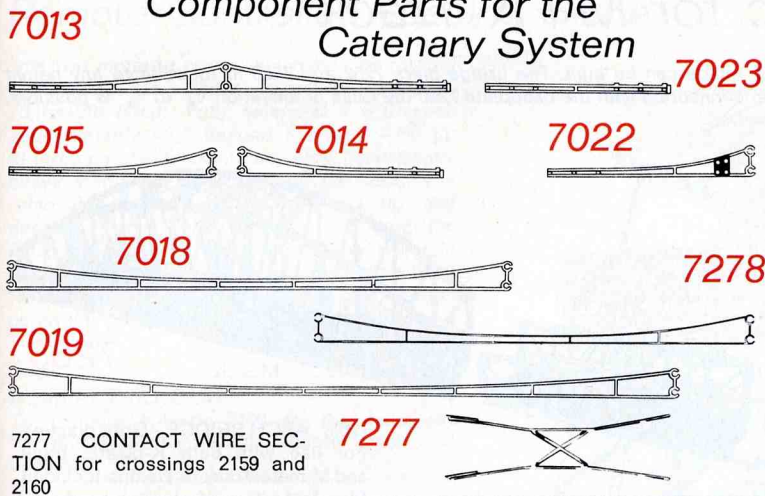

7013 CONTACT WIRE SECTION, with slide together connection at each end, for straight and curve track and for use over turnouts · 9 1/2" long

7014 CONTACT WIRE SECTION with slide connection · 4 1/2" long

7015 CONTACT WIRE SECTION with slide connection · 4 1/2" long

7018 CONTACT WIRE SECTION for straight and curved track · 10 3/4" long

7019 CONTACT WIRE SECTION for straight track only · 14 1/2" long

7022 INSULATOR SECTION CONTACT WIRE for interrupting current · With slide connections · 4 1/2" long

7023 MAKE-UP CONTACT WIRE SECTION, with slide connections at each end · 4" long

7278 CATENARY WIRE SECTION, designed for use with track section 2121 · Length 9 1/4"

7230 MOUNTING PLATE · Required when the mast of signals 7238 through 7242 is installed separately from the electric solenoid drive unit



7231 MOUNTING PLATE · Required when connecting Warning Signals 7236/7237 to 5100/5200 Series track



7200 MÄRKLIN Signals for MÄRKLIN K+M Track

The Light Home Signals and the Siding Signal of 7200 series are equipped with contacts for automatic operation of trains, whether picking up power through the center contact on the track or from the catenary system. The masts of these signals can be installed on the layout separately from the solenoid control unit. In this case the mounting plate 7230 is required to connect the mast to the track. When using the signals with 5100/5200 series track the 7231, 7232 and 7233 mounting plates are required to connect to "ground." When used with 2100 series track, 7531, 7532 and 7533 are required.

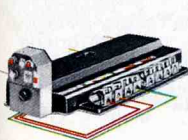

7242 DWARF SIDING SIGNAL · Lights change from red/red (stop) to white/white (proceed with extreme caution) and start and stop the trains automatically · Two light bulbs in housing · Lever for hand operation · Width: 1 1/8" · Length: 3 3/4" · Height: 3/4"



7245 UNIVERSAL TRAIN CONTROL · Can be used for automatically running trains and automatically turning on and off lighting current · The control can be operated by track contacts or from the control panel · Lever for hand operation · The many uses of this control are covered in the instructions and the Signal Manual · Width: 1 1/8" · Length: 2 3/4" · Height: 3/8"



7236 LIGHT DISTANT SIGNAL · Lights change from yellow/yellow (caution) to green/green (proceed) · Signal has four separate lamps · Has terminals for connection with Light Home Signal 7239 · Comes with mounting plate 7230 · Width: 5/8" · Length: 1 1/8" · Height: 2 3/4"



7237 LIGHT DISTANT SIGNAL · Lights change from yellow/yellow (caution) to yellow/green (proceed with caution) · Signal has four separate lamps · Terminals for connection with Light Home Signal 7240 · Comes with mounting plate 7230 · Width: 5/8" · Length: 1 1/8" · Height: 2 3/4"



7238 LIGHT DISTANT SIGNAL · Lights change from yellow/yellow (caution) to green/green (proceed) or green/yellow (proceed with caution) · Signal has four separate lamps · Equipped with a double solenoid · For connection to Light Home Signal 7241 · Width: 5/8" · Length: 1 1/8" · Height: 2 3/4"

Insulators for center stud contacts, terminals for center stud contacts and instructions are supplied with the home signals 7239, 7240 and 7241.

7539 LIGHT HOME SIGNAL · Lights change from red (stop) to green (proceed) by manual operation, with simultaneous control of the traction current in the central conductor of the solidly attached piece of track · An additional piece of track 3 1/2" long with interrupted stud contacts · Width: 2" · Length: 3 1/2" · Height: 3 1/2"

7539 for K Track only

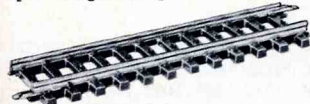

7232 MOUNTING PLATE · Required when connecting Light Signals 7238, 7239, 7240 and 7242 to 5100/5200 series track



7233 MOUNTING PLATE · Required when connecting Light Signal 7241 to 5100/5200 series track

7531 MOUNTING PLATE for connecting the Light Distant Signals 7236/7237 to 2100 series track



7532 MOUNTING PLATE for connecting the Light Signals 7238, 7239, 7240 and 7242 to 2100 series track



7239 LIGHT HOME SIGNAL · Lights change from red (stop) to green (proceed) and start and stop trains automatically · 2 light bulbs · Lever for hand operation · Width: 1 1/8" · Length: 2 3/4" · Height: 3 1/2"



7240 LIGHT HOME SIGNAL · Lights change from red (stop) to green/yellow (proceed with caution) and start and stop the trains automatically · 3 light bulbs · Lever for hand operation · Width: 1 1/8" · Length: 2 3/4" · Height: 3 1/2"



7241 LIGHT HOME SIGNAL · Lights change from red (stop) to green (proceed) or to green/yellow (proceed with caution) and start and stop the trains automatically · Has additional solenoid for the green/yellow position · 3 light bulbs · 2 levers for hand operation · Width: 1 1/8" · Length: 3 3/4" · Height: 3 1/2"



7533 MOUNTING PLATE for connecting the Light Signal 7241 to 2100 series track

MÄRKLIN Bridges in Plastic for M+K Track

With these MÄRKLIN bridge parts any size and combination of bridges and ramps can be built. The bridge piers 7252 and 7253 fit together to any height desired by raising the elevation of 1/4" to 1/4". When using the baseplate 7251 in connection with the baseplate 7250 the raise of elevation 1/8" to 1/8" is possible. For attaching the bridge piers to the base we recommend using flat head screws.

7269 CURVED APPROACH SECTION · Grey plastic · 18" radius for use with M-track 5200 · Full length

7262 TRUSS BRIDGE · Grey plastic · Can be used alone or with arch bridge 7263 · For use with both K-plastic track and M-metal track · Three clamps included for fastening plastic track to bridge · Height: 1 3/4" · Length: 7"

new
7269

7269 only for **M**



M + K
7267

7569 only for **K**
7569



M + K 7268

7262 M + K



M + K 7263

7263 ARCH BRIDGE · Grey plastic · For use with both K-plastic track and M-metal track · 6 clamps included for fastening K-plastic track to bridge · Height 4 1/2" · Length 14"

7569 CURVED APPROACH SECTION · Grey plastic · Designed to accept 17" radius track · Only for use with K-plastic track · Three clamps included for fastening K-track to approach · Length and radius the same as track section 2131

7267 CURVED APPROACH SECTION · Grey plastic · Designed to accept 15" radius track · For use with both K-plastic track and M-metal track · 3 clamps included for fastening K-plastic track to approach · Length and radius the same as 2121

7268 STRAIGHT APPROACH SECTION · Grey Plastic · For use with both K-plastic track and M-metal track · 3 clamps included for fastening K-plastic track to approach · Length 7"

7250 7251



Bridges - Piers

7252 7253



7250 PIER BASE PLATE · 3/16" high · Light brown plastic · For use at foundation

7252 PIER · 1/4" high · Grey plastic · Very suitable for building bridge approach grades with a 1/4" rise between sections

7251 PIER BASE PLATE · 1/8" high · Light brown plastic · To be used in connection with 7250

7253 PIER · 1 1/4" high · Grey plastic

Basic HO Scale Track Layouts for K-Track

K

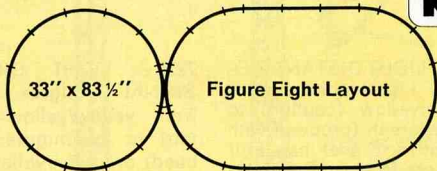
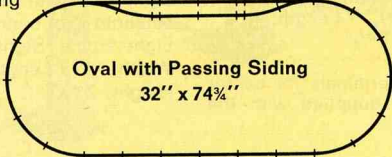

Figure Eight Layout

Track sections: five 2100, eighteen 2121, four 2123, two 2131, four 2135, one 2190, one 2159 or 2160 crossing



Oval with Passing Siding
32" x 74 1/2"

Track sections: nine 2100, two 2107, four 2108, twelve 2121, two 2132, one 2190, one pair of 2161 or 2164 turnouts

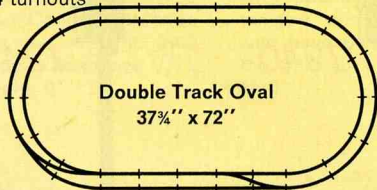

Double Track Oval
37 1/2" x 72"

Track sections: eleven 2100, two 2106, four 2107, twelve 2121, ten 2131, one 2190, two 2161 or 2164 turnouts, one pair of 2167 turnouts

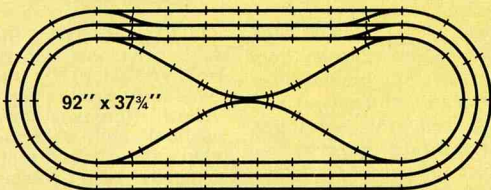

92" x 37 1/2"

Three Track Oval with Double Reverse Loop

Track sections: eleven 2100, six 2101, four 2104, twenty-two 2106, ten 2107, eight 2110, twelve 2121, twelve 2131, four 2133, four 2134, four 2135, one 2190, one 2159 or 2160 crossing, six pairs of 2161 or 2164

7511



7511 BRIDGE MAST · For hanging catenary wires on bridges and approaches · 3 7/8" high · For catenary masts and catenary wires, see page 50/51.

7234



7234 BASE FOR MAST · For fastening the signal masts of series 7200 to bridges · Fastening plate for signal mast included

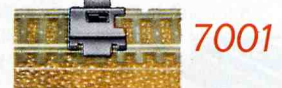
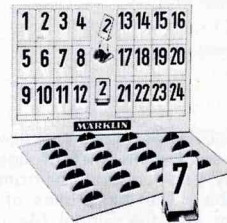

7001 COUPLER HEIGHT GAUGE · For checking the couplers on rolling stock · Nickel plated steel · Instructions included

7195

7195 SET OF NUMBER PLATES · For marking the location of turnouts, signals, etc. · Contains 12 slotted metal bases and number cards, 1—24

K

Accessories

0207 TRACK PLANNING TEMPLATE · Transparent Plastic · An indispensable aid for designing track plans · 1:10 scale covers all track sections of the 2100 series

0207

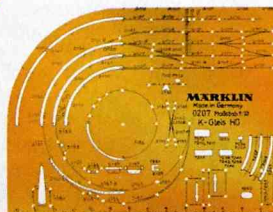

Light Bulbs
for locomotives:

60000 3005, 3015

60001 3071, 3076

60010 3000, 3003, 3016, 3021, 3031, 3046, 3047, 3048, 3064, 3065, 3072, 3073, 3095

60015 3022, 3030, 3034, 3035, 3036, 3037, 3038, 3039, 3040, 3043, 3044, 3050, 3051, 3054, 3059, 3060, 3061, 3066, 3067, 3068, 3071, 3075, 3076, 3078, 3089, 3094, 3096, 3098

Remote Controlled Loading Crane

This two motored crane, which may be rotated continuously in either direction, has an adjustable boom. Fully extended it will reach approximately 4 3/4" beyond the base,—for up to three parallel tracks on any side. Surprisingly heavy loads can be lifted with the hook. The removable electric magnet will pick up, and deposit, ferrous metal objects including the loads on container cars. This crane will add much interest to your layout and provide a most realistic loading operation. The push button controller provides precise remote control.

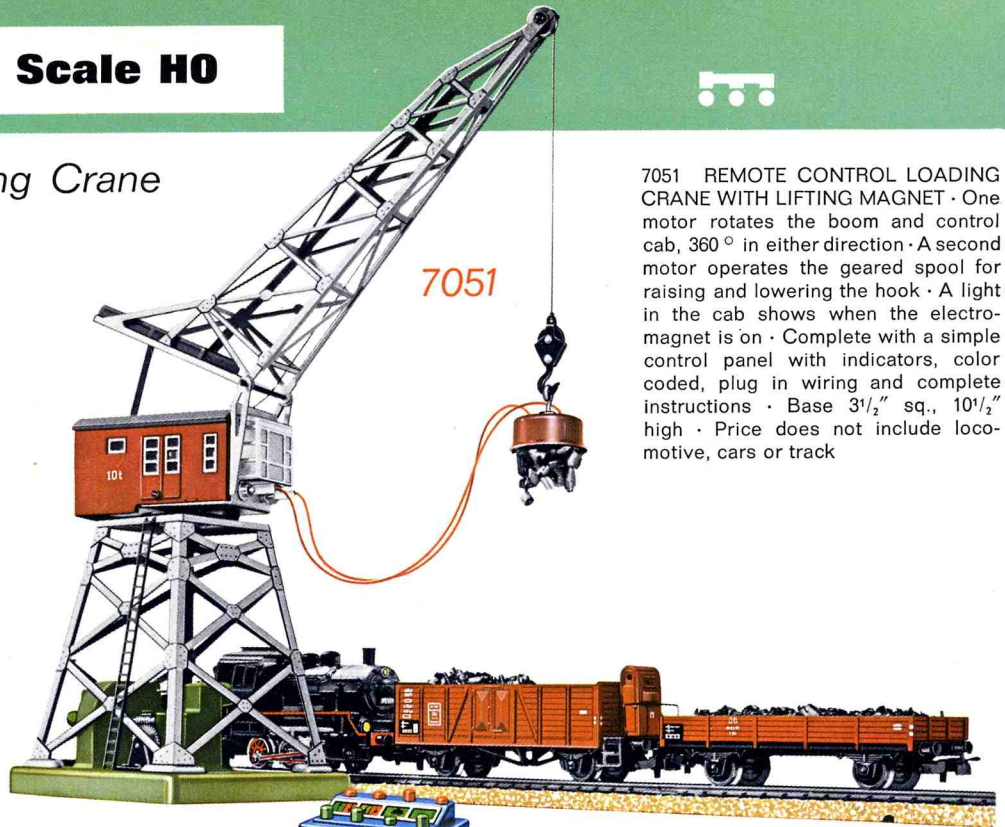

7051 REMOTE CONTROL LOADING CRANE WITH LIFTING MAGNET · One motor rotates the boom and control cab, 360° in either direction · A second motor operates the geared spool for raising and lowering the hook · A light in the cab shows when the electromagnet is on · Complete with a simple control panel with indicators, color coded, plug in wiring and complete instructions · Base 3 1/2" sq., 10 1/2" high · Price does not include locomotive, cars or track

Adapter Track 2191

To connect K-track 2100 to the automatic turntable 7186 use straight adapter track 2191 (see page 49).

Automatic Turntable

7186

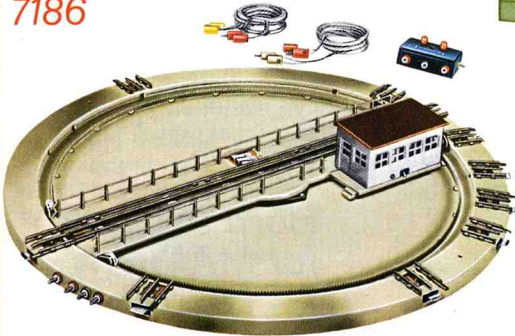

7186 REMOTE CONTROLLED TURNTABLE · 14 inch outside diameter · Table turns 360° in either direction and stops automatically at each track · Complete with control panel, connecting cables and illustrated instructions · Current is automatically shut off in all tracks not aligned with turntable track

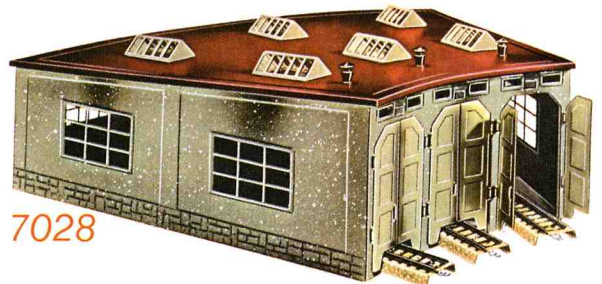

7028

Locomotive Roundhouse

7028 ROUNDHOUSE for three tracks, with skylights, smoke jacks, realistically painted in three colors · Doors open and close automatically · (Track not included) · 18 1/8" x 14 5/8" x 5 1/4"

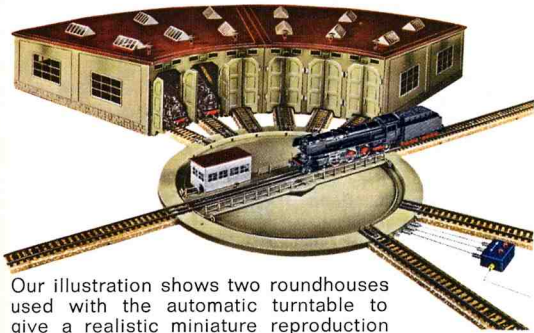

Our illustration shows two roundhouses used with the automatic turntable to give a realistic miniature reproduction of the original.

A turntable and roundhouse help to complete your model railroad. The turntable is used to turn locomotives so that they can be sent back out onto a new run. In addition the turntable serves to distribute the locomotives to the different stalls of the roundhouses. The turntable and roundhouse can also be used for diesel locomotives as well as steam locomotives as many areas are servicing both locomotives in the same facilities. All tracks not in contact with the turntable bridge have the current turned off, so no other switch is needed.

For MÄRKLIN HO Locomotives

Rubber Tires
for locomotives:

7152 3005, 3048, 3089, 3094, 3098

7153 3003, 3015, 3016, 3022, 3030, 3034, 3035, 3036, 3037, 3038, 3039, 3040, 3043, 3046, 3047, 3050, 3054, 3059, 3064, 3065, 3095, 3096

7154 3000, 3021, 3029, 3031, 3044, 3051, 3060, 3061, 3066, 3067, 3068, 3071, 3072, 3073, 3075, 3076, 3078, 3080

Reverse Unit Spring

7194 Packed with 5 replacement springs

See the locomotive instructions for replacing pick up shoes, rubber tires and reverse spring.

For Horn Units for MÄRKLIN locomotives, see page 54

Current Pickup Shoes
for locomotives:

7164 3034, 3035, 3036, 3037, 3038, 3039, 3040, 3043, 3050, 3051, 3054, 3059, 3066, 3067, 3068, 3071, 3072, 3075, 3076, 3096

7166 3029, 3044, 3078, 3080, 4060, 4061

7173 3000, 3003, 3005, 3030, 3031, 3095

7174 3016, 3048

7175 3015, 3046, 3047

7183 3021, 3073

7185 3022, 3060, 3061, 3064, 3065, 3089, 3094, 3098

Pantograph

7218

7218 Double Arm Pantograph · With mounting screws



Lubricating Oil

7199 Oil · Bottle containing about 1 oz. of lubricating oil for locomotive and cars



0241

Smoke Fluid

0241 Smoke Fluid in plastic capsule for locomotive 3046, 3047, 3048

Pantograph

7219



7219 Single Arm Pantograph · The catenary system must be set very carefully when using the 7219 pantograph · Use only the 7277 at crossings

60030 Replacement Brushes for most HO locomotives

60035 Replacement Brushes for 3015

60054 Brushes, contains two replacement graphite brushes for locomotives with permanent magnet (D.C.) motors

Grade Crossings with Automatic Gates

7192 ELECTRIC OPERATED GRADE CROSSING GATES with M-Track sections · The grade crossing has two automatic electric gates operated by the train · Crossing guards shed (designed to accept interior lighting) · Complete with instructions and two control tracks

The crossing operates entirely automatic, the gates closing as soon as a train runs onto the track control section in front of the gates, and open again automatically when the train leaves the last section of control track after the crossing.

For multi-track operation the 7192 crossing gates can be used with the 7193 extension set. The automatic operation will still be retained.

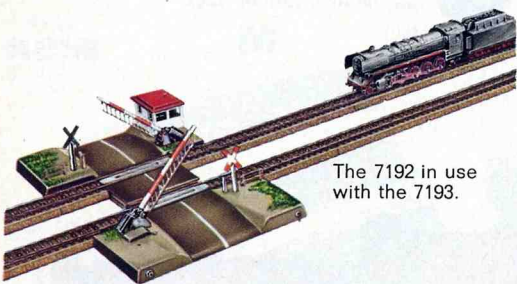

The 7192 in use with the 7193.

5115
5115 straight · 7" long
ACTUATING TRACKS

5116
5116 curved · 15" radius

These track sections are for extending the control tracks sections of the 7192 grade crossing gates.



7193 EXTENSION SET for adding parallel tracks to the 7192 crossing gate · Contains two control track sections, the center crossing track and a road extension piece to fit between the two tracks

To connect K-track 2100 to the grade crossing gate 7192 and 7390 use straight adapter track 2191 (see page 49).

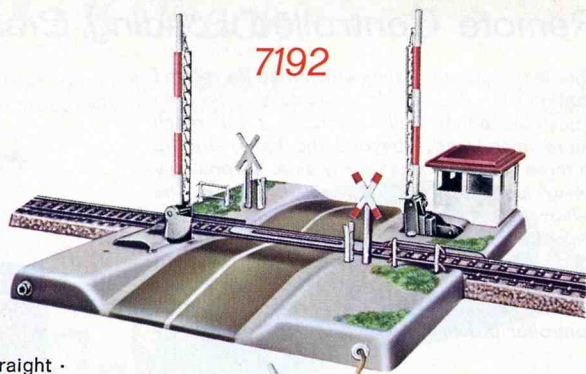

7192

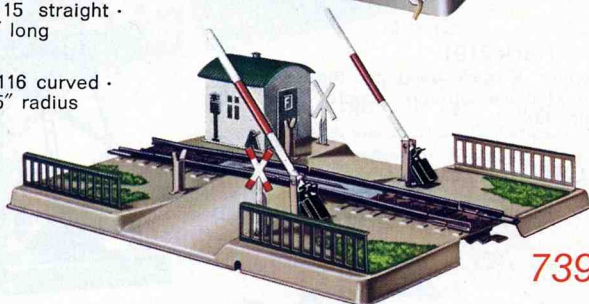

7390

7390 MECHANICALLY OPERATED GRADE CROSSING GATES for single track lines · With 7" straight M-Track section · The gates are closed by floating bars pressed down by the wheels of the passing train · Crossing guards shed and railings · Size of base: 4 3/4" by 7"



new

7221

Warning Bells for all Scales

7221 WARNING BELL, two tones · Electrically operated · Maximum voltage 16 V · Operated by control panel · Height: 1 5/8", length 2"



7222

7222 WARNING BELL, two tone · Hand operated · Height: 4" · Diameter for base: 1 1/2"

new



new
7223

7223 RADIO INTERFERENCE CONTROL · Eliminates interference with radio and TV broadcasts while running the trains · Connect between transformer and track · Blue case · 1 red and 1 brown cable · 1 3/8" x 1 3/4" x 3/4"

Accessories for Remote Control Operation



7072

7072 CONTROL PANEL with eight sockets for plugging in at least four impulse operated electric accessories (i. e. turnouts, signals, etc.) · The arrangement of the push buttons will indicate the position of the accessory · 3 1/4" long · 1 3/4" wide



7210

7210 SWITCH PANEL for turning on and off the train and lighting circuits · The four indicator push buttons are connected to a common circuit · 3 1/4" long · 1 3/4" wide

Circuit diagram for 7210 (Switch No. 3 closed)



7211

7211 SWITCH PANEL for turning on and off the train and lighting circuits · The four indicator push buttons are insulated from each other · 3 1/4" long · 1 3/4" wide

Circuit diagram for 7211 (Switch No. 3 closed)



7209

7209 DISTRIBUTION PANEL with 11 sockets · 2" x 3 3/4"



7229

7229 DISTRIBUTOR PANEL · With five wire clamps connected in series · 1 1/2" long · 3/8" wide



7228

7228 DISTRIBUTOR PANEL · With five wire clamps insulated from each other · 1 1/2" long · 3/8" wide

Electronic Warning Horn



Horn Equipment for MÄRKLIN Locomotives

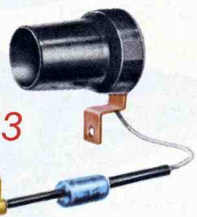

7213

The series of MÄRKLIN Locomotives listed under 7213 have provision for installing the warning horn. One or several may be sounded by pressing the button of 7215 Horn Sounding Unit, placed between the feeder track and the transformer. It supplies special power to operate the horn, but not the motor, of the locomotive when they are standing still on the track, transformer speed control knob off ('O').

The Horn Running control 7216 is added between the Horn Sounder and the feeder track to make the horn sound on running locomotives. Finally to sound the horn of a locomotive standing on a 'dead' track at a signal or insulated track section, the 7217 Horn Signal Control is added to bridge the electrical insulation point.

The tone of 7213 Horn is the high pitched sound as found on European Locomotives. A moving train can sound its horn automatically by using contact tracks and the 7045 Universal Remote Switch, or 7245 (see pages 44 and 51). For contact tracks see pages 42 and 48.

7213 WARNING HORN COMPLETE · Ready to install in MÄRKLIN locomotives 3022, 3034, 3035, 3036, 3037, 3038, 3039, 3040, 3043, 3050, 3051, 3054, 3059, 3060, 3061, 3066, 3067, 3068, 3071, 3073, and 3075 and some models of 3021 · No soldering is required · In certain models of 3021 one lead must be soldered · Complete with illustrated installation instructions



7216



7215

7216 HORN RUNNING CONTROL · For use in conjunction with the Horn Sounder 7215, to sound the horn when a locomotive is stopped or running · One red connecting cable with plug · 2" x 1 1/4" x 1"



7217

7215 HORN SOUNDING UNIT · For sounding the locomotive horn · Three connecting cables, red, brown and yellow, with plugs · 3" x 2 1/8" x 1"

7217 HORN SIGNAL CONTROL · For use with the Horn Sounder when ever a locomotive is stopped by a home signal in the "dead" section of track · Two connecting cables · 2" x 1 1/4" x 3/5"

Complete instructions are supplied with the horn sounding unit.



The Magazine
for all
Model
Railroaders

Articles on
Prototype and
Model
Railroads

The MÄRKLIN-magazine is full of interesting reports of developments of the MÄRKLIN products, model railroad ideas and reports of real railroads.

The magazine is topical, up to date, and provides much worthwhile information for all railway enthusiasts. Modeling tips, track plans, equipment plans, plus many interesting photos. MÄRKLIN-magazine is available only in the German language.

The magazine is published four times a year.

Available at your MÄRKLIN dealer or direct from:
Modellbahnen-Welt
Verlags-GmbH,
732 Göppingen, Postfach 940
Germany

MÄRKLIN magazin

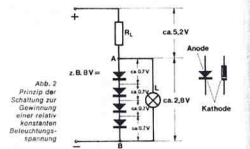

Wir bauen eine Ladestraße mit Rammen

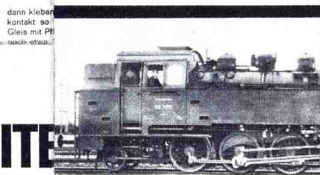

Automatischer 7-Zug-Betrieb auf 11 qm

MÄRKLIN MESSE-NEUHEITEN

technische revolution im nah- und fernverkehr

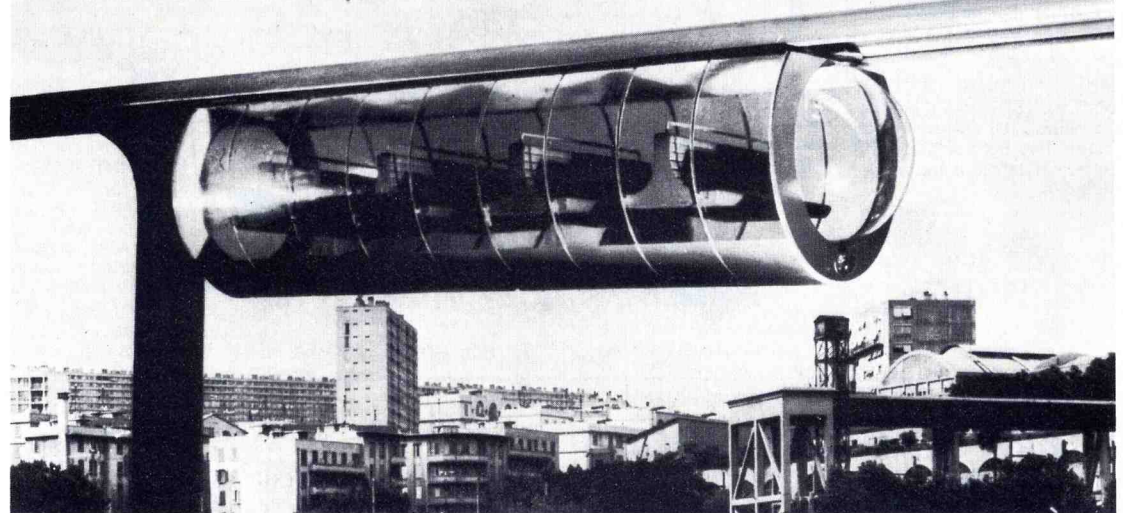

0380

0380 HANDBOOK "MÄRKLIN HO RAILWAYS AND THEIR PROTOTYPE" · A complete handbook for the MÄRKLIN fan · Covers operation of MÄRKLIN cars and locomotives, construction of layouts, information on actual railroad practice, function of signals and automatic operation of trains

plus many other subjects · 228 pages · 9 1/2" by 6 1/4" · German text



0341



0341 MÄRKLIN SIGNAL MANUAL · A complete illustrated guide for using the 7000 Series of signals · Printed in six colors, giving information about automatic train control and many other features including the universal remote switch · 44 pages · 8 1/4" by 6"

MÄRKLIN BOOKS

Available at your MÄRKLIN dealer



0351



0351 ADVANCED MÄRKLIN HO TRACK PLANS FOR M-TRACK 5100 AND 5200 · Contains 20 different track plans with full descriptions and suggestions for adding scenery · Full color illustrations of 13 of the track plans completed as model railroads · A special section shows hundreds of combinations of turnouts, crossings and other sections · 86 pages · 8 1/4" x 11 3/4"



new



0371

0371 MÄRKLIN HO TRACK PLANS FOR K-TRACK 2100 · Contains full color illustrations and track plans of 16 completed layouts with catenary system · The various current circuits are marked with different color · This manual also contains many plans of various combinations of track sections and turnouts · An indispensable guide for building large layouts · 52 pages · Size 8" by 12"

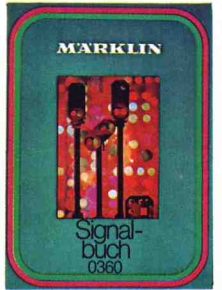

0361

0361 MÄRKLIN SIGNAL MANUAL · A complete illustrated guide explaining the operation and advantages of our 7200 Series Signals · 48 pages · 7" by 9 1/2"



0321

0321 MÄRKLIN HO TRACK PLANS FOR M-TRACK 5100 AND 5200 · Contains 16 beginners track plans · 24 pages · 8 1/4 x 6"



0379



0379 MÄRKLIN HO TRACK PLANS FOR K-TRACK 2100 · A comprehensive guide for building layouts · 20 pages · 8 1/4" by 6"

Interior Coach Lighting

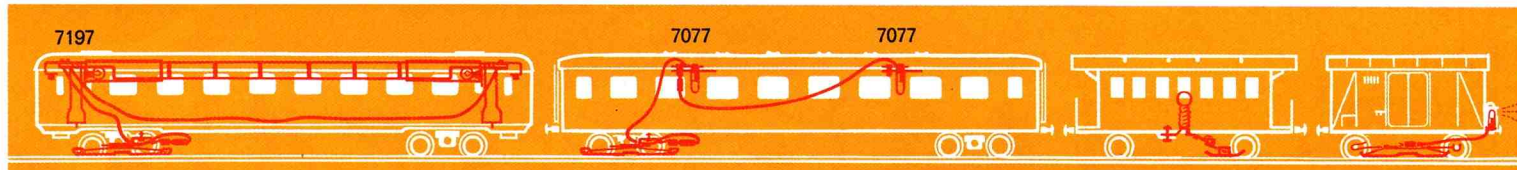

7074
 7074 INTERIOR LIGHTING for passenger cars 4002, 4003, 4004, 4005, 4079, 4080 · With socket for additional lighting

new 7323
 7323 LIGHTING for coaches 4007 and 4008

7076
 7076 CURRENT PICKUP SHOE for the 7079 taillights · Use with passenger cars 4000 and 4040 and some four wheel freight cars

It's easy to wire using the MÄRKLIN color coded system:

- Red = For running trains · From transformer to center track studs or overhead catenary contact wires
- Yellow = Lighting and electrically operated accessories
- Brown = Ground wire return from track, accessories and control panels
- Blue = Blue ground wire from magnetically operated accessories (turnouts, signals etc.) to control panels or contact tracks

7077
 7077 INTERIOR LIGHTING for all 8 wheel passenger cars, not otherwise listed · Socket for connecting additional lighting · Bulb included

7079
 7079 TAIL LIGHT with bulb · Clips onto buffer · (Not for express coaches on pages 29, 30, and 31, nor on cars with plastic buffers) · Connect with 7074, 7076, 7077 or 7198

7198
 7198 CURRENT PICKUP SHOE for use with the 7077 lighting unit

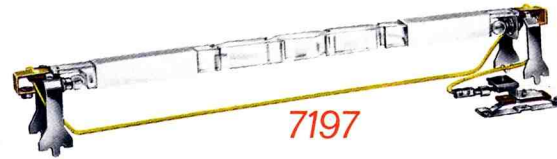

7322
 7322 INTERIOR LIGHTING UNIT for TEE Dome Car 4090 · Contains 7198 current pickup shoe · Two light sockets with bulbs · Illustrated instruction includes

7320
 7320 INTERIOR LIGHTING UNIT for Tee Coaches 4085, 4086, 4087, 4088 and express coaches 4047, 4048, 4049, 4064, 4065, 4066, 4068, 4075, and 4078 · Contains 7198 current pickup shoe, lucite lighting bar, and two light sockets with bulbs · Provides full length, diffused lighting as on the prototype · Instructions included

7197
 7197 INTERIOR LIGHTING UNIT for passenger coaches 4050, 4072, 4073 · Contains 7198 current pickup shoe, lucite lighting bar, and two light sockets with bulbs · Provides full length, diffused lighting as on the prototype · Instructions included

Lighting Accessories

7046
 7046 TOWER MAST YARD LIGHT · For use with Catenary system · 8 1/4" high · Base 1" x 1 1/4" · With bulb, cables and plugs

7048
 7048 STREET LIGHT · 6 1/4" high · Base 1 1/4" diameter · With bulb, cables and plugs

7047
 7047 STATION PLATFORM LIGHT · For use at stations, on streets etc. · 5" high · Base 1 1/4" diameter · With bulb, cables and plugs

Wire

This is a special, highly flexible stranded copper wire for connecting all MÄRKLIN trains and accessories. A heavy duty wire able to withstand great loads, including short circuits without damage. For use with transformers up to 50 VA.

7080 EXTENSION CABLE · With 1 plug and 1 socket · Grey · 39" long
7090 EXTENSION CABLE · With 1 plug and 1 socket · Grey · 78" long
7100 WIRE · Single strand · 33' long · Grey
7101 WIRE · Single strand · 33' long · Blue
7102 WIRE · Single strand · 33' long · Brown
7103 WIRE · Single strand · 33' long · Yellow
7105 WIRE · Single strand · 33' long · Red

7141
 7141 INTERMEDIATE DOUBLE PLUG · For connecting two sockets · Metal

7140
 7140 CROSS PLUG · For connecting two plugs and two sockets

7000
 7000 STAPLES FOR WIRES · Bag of 50 for mounting cables to wooden base

- | | |
|----------------|---------------|
| SOCKETS | PLUGS |
| 7111 = brown | 7121 = brown |
| 7112 = yellow | 7122 = yellow |
| 7113 = green | 7123 = green |
| 7114 = orange | 7124 = orange |
| 7115 = red | 7125 = red |
| 7117 = grey | 7127 = grey |

7220
 7220 PICK UP SHOE · For use when operating railbus trailers 4018 or cars, which have the interior lighting 7074, on layouts which have the curved turnouts 2167 · 1" long

7220
 7220 PICK UP SHOE · For use when operating railbus trailers 4018 or cars, which have the interior lighting 7074, on layouts which have the curved turnouts 2167 · 1" long

- | | |
|--------------------------------|---------------|
| PLUGS WITH SIDE SOCKETS | |
| 7131 = brown | 7134 = orange |
| 7132 = yellow | 7135 = red |
| 7133 = green | 7137 = grey |



MÄRKLIN Transformers are safe and reliable

The sheet steel case and heavy insulation of the MÄRKLIN transformers, tested at several thousand volts, make them absolutely safe. A built in circuit breaker turns off the transformer automatically should there be a short circuit in the layout. The transformer plugs into the house circuit with a heavy duty, UL approved line cord.

The speed of the locomotive increases as you turn the control knob to the right, decreases as you turn it to the left. The same control knob reverses the locomotive. Rotate the knob left, past "O" momentarily, thus activating the 24 volt reversing circuit. The locomotive is automatically reversed. The locomotives can be operated at a slower speed with the 30 VA 6100 Series Transformer, than with the 16 VA 6500 Series.

We guarantee perfect operation of our trains, only when original MÄRKLIN transformers are used.

MÄRKLIN Transformers of the 6100 and 6500 Series have plug in connections for operating trains and accessories.

Transformer for Lighting

Connection up to 50 bulbs possible



16 VA

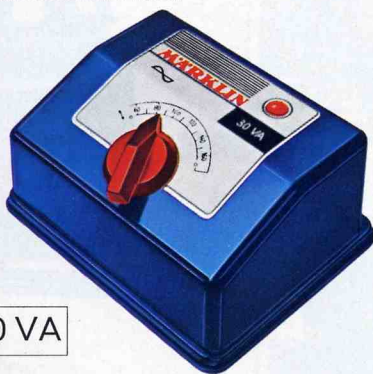

30 VA

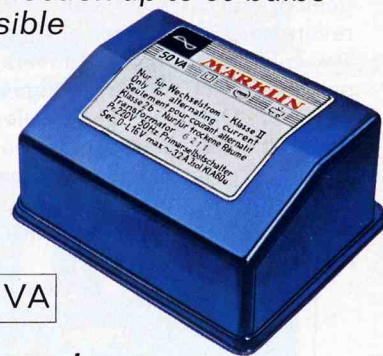

50 VA

To be connected to A. C. mains only

TRANSFORMER · Output 16 VA · Weight 3 lbs. · Size 4 3/4" x 3 3/4" x 3"

TRANSFORMER · Output 30 VA · Red pilot light · Weight 4 1/2 lbs. · Size 6 1/8" x 5 1/8" x 3"

TRANSFORMER FOR LIGHTING AND ELECTROMAGNETIC ACCESSORIES · Output 50 VA · Weight 4 1/2 lbs. · Size 6 1/8" x 5 1/8" x 3"

6500 = 100 Volt for Japan

6507 = 115 Volt for USA

6114 = 110 Volt

6153 = 110 Volt for USA

6211 = 220 Volt

6501 = 110 Volt

6509 = 240 Volt for England

6115 = 125 Volt

6158 = 100 Volt for Japan

THE POWER REQUIRED BY LOCOMOTIVES AND ACCESSORIES HAS BEEN CALCULATED AS FOLLOWS:

6505 = 125 Volt

6511 = 220 Volt

6117 = 220 Volt

6166 = 240 Volt for England

With maximum load, 3000 loco takes 9 VA, 3021 loco takes 12 VA and the 3048 loco about 15 VA. The power left over can be used for accessories with each lamp using approximately 1 VA.

When you place an order please note the special number in your case.

When you place an order please note the special number in your case.

All transformer are supplied with a two wire cable and general (European type) plug.

The transformers that are supplied with the starter sets on page 2 have the same general specifications as these transformers. The only difference is their smaller capacity.

A fascinating hobby— A pleasure for leisure time—



MÄRKLIN

—for children as well as for adults—

Minex

*"O" Scale Narrow Gauge Railway
Operates on HO Gauge Track*

Steam Locomotive

3400 STEAM LOCOMOTIVE · Model of a narrow gauge locomotive of the Württemberg Railway Co (WEG) · 0-6-0 wheel arrangement · All wheels driven · Remote control reversing · Exact replica of Allan valve gear · Two rubber tires on rear drivers to increase pulling power · Three working headlights on the front · Outstandingly detailed plastic body with many extras, black boiler and green cab · Plastic windows inset in frames · Die cast metal frame · Delayed action automatic couplers (RELEX) at each end · 5½" long

3400

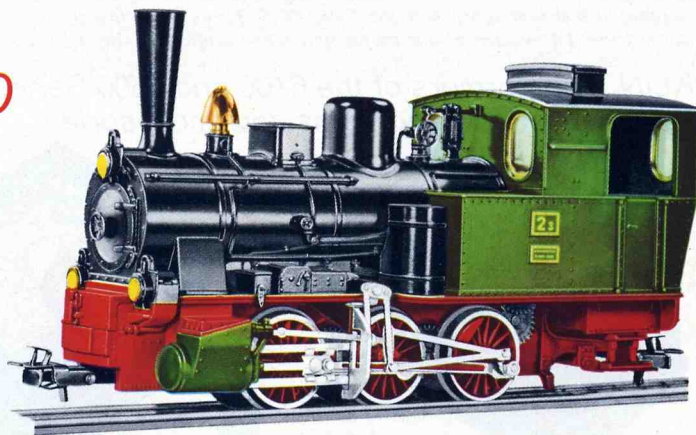

Diesel Locomotive

3420 DIESEL LOCOMOTIVE · Model of a narrow gauge locomotive of the Southwest German Railway Co (SWEG) · 0-6-0 wheel arrangement with rear drivers powered · Two rubber tires to increase pulling power · Remote control reversing · Three working headlights on the front · Orange plastic body with stripes · Silver colored roof · Grey die cast metal frame · Windows have frosted plastic · Delayed automatic couplers (RELEX) at each end · 4¾" long

3420



Minex *Train Set (without transformer)*



Passenger Train

3450

3450 PASSENGER TRAIN (without transformer) · With Steam Locomotive 3400, 1 passenger coach 4400, 1 passenger coach 4401, 1 straight track 5106, 1 straight feeder track 5111 and 12 curve track 5200 · Train measures 20" long



Scale 1:45



Passenger Car 4400

4400 PASSENGER COACH · Second class · 4 wheeled · Red plastic body · Platform and opening doors on each end · Complete interiors · Plastic windows inset in frames · Light grey roof, weathered at the edges · Length: 6 1/2"

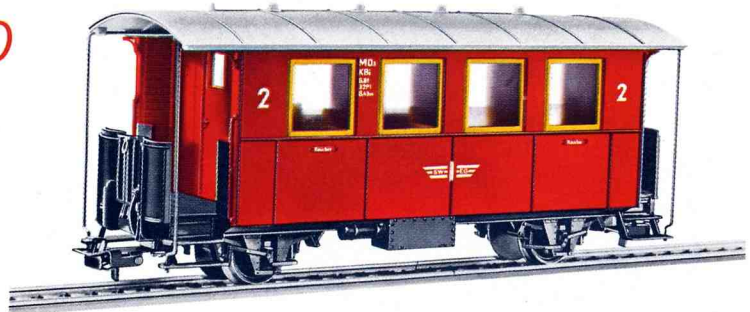

Passenger Car 4401

4401 PASSENGER COACH · Second class · 4 wheeled · Dark green plastic body · Platform and opening doors on each end · Complete interiors · Plastic windows inset in frames · Light grey roof, weathered at the edges · Length: 6 1/2"

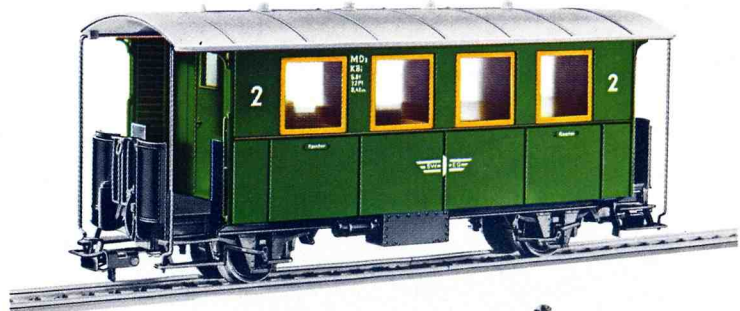

Home Signal

7400 HOME SIGNAL · Operated by hand to move the semaphore arm and control the current to the center stud of the connected track, to start and stop the train · An additional piece of track included has an insulated center stud · Length: 3 1/2" · Width: 2 1/4" · Height: 6 1/4"

new
7400



Minex Train Set (without transformer)



Freight Train

3470

3470 FREIGHT TRAIN (without transformer) · With Diesel Locomotive 3420, 1 gondola car 4450, 1 dump car 4459, 1 straight track 5106, 1 straight feeder track 5111 and 12 curve track 5200 · Train measures 18 3/4" long

Minex

*"O" Scale Narrow Gauge Railway
Operates on HO Gauge Track*

Scale 1:45

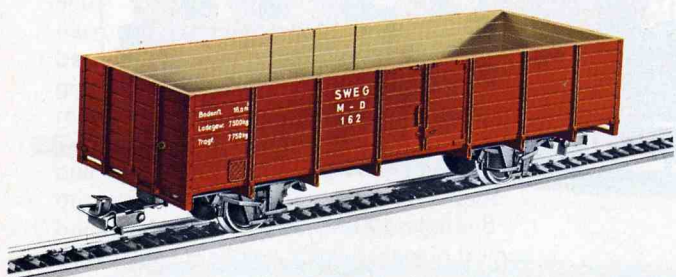

4450 4450 OPEN GONDOLA CAR · 4 wheeled · Body brown · Black underframe · Length: 6 1/4"



4452 4452 BOXCAR · 4 wheeled, brown, grey roof · Sliding doors open and close · 6 1/2" long

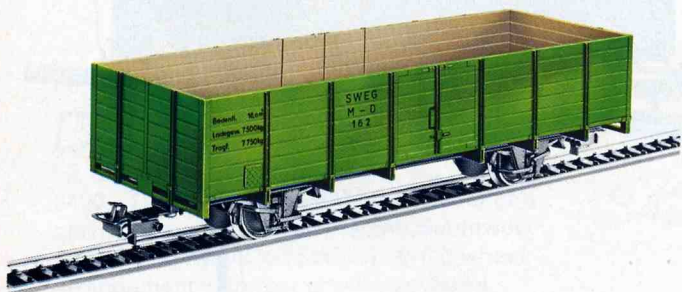

4451 4451 OPEN GONDOLA CAR · 4 wheeled · Body green · Black underframe · Length: 6 1/4"

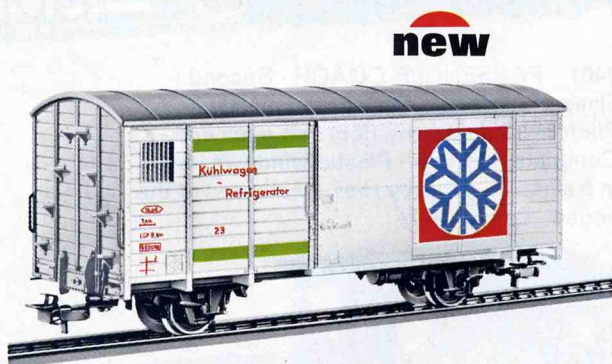

4453 4453 BOXCAR · 4 wheeled · White · Grey roof · Sliding doors open and close · 6 1/2" long

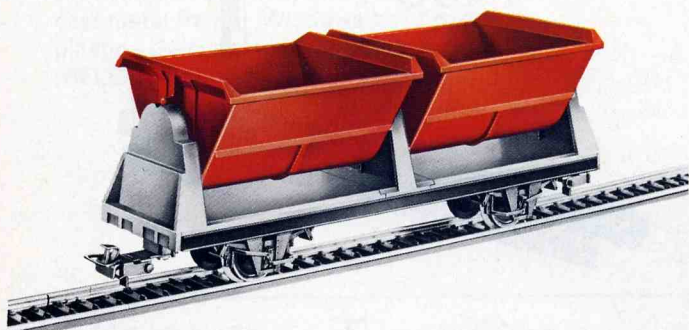

4459 4459 DUMP CAR · 4 wheeled · Two dumping hoppers that can be independently tipped to either side · Hoppers lock in upright position · Hoppers red with grey supports · Black underframe · Length: 6 1/4"



4454 4454 BOXCAR · 4 wheeled · Blue · Grey roof · Sliding doors open and close · 6 1/2" long

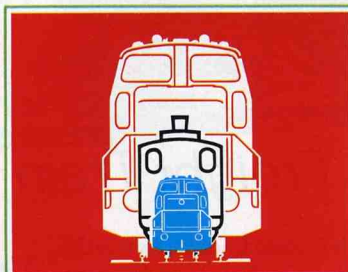

Relationship of sizes:
No. I Gauge
Minex
HO Scale

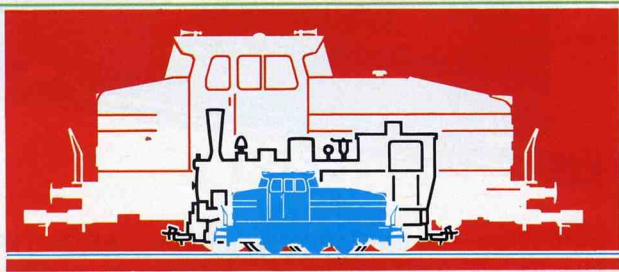

No. I Gauge Locomotives/Train Set



MÄRKLIN No. I Gauge Two Rail-A. C.

5700 TANK LOCOMOTIVE · A model of the German Federal Railways' Class 80 · 0-6-0 wheel arrangement · 2 special adhesion tyres · Automatic control for forward and reverse operation · Exact reproduction of the Heusinger drive rod system · High reduction gears · Three working headlights on each end · Dull black plastic body · Cab doors open and close · Windows have inset plastic frame · Fully detailed die cast metal frame · Automatic coupler and working sprung buffers on both ends · Length: 12"

5700

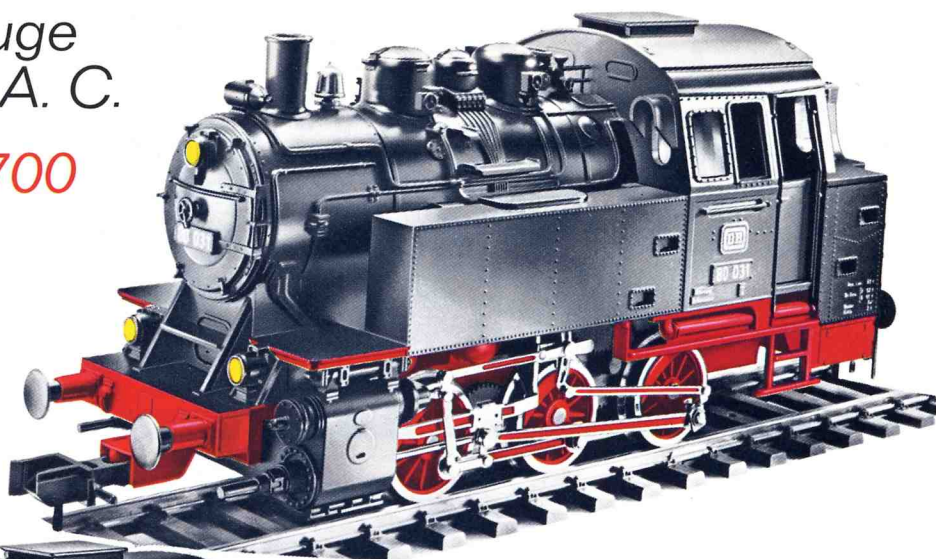

Tank Locomotives

5702 TANK LOCOMOTIVE · 0-6-0 wheel arrangement · 2 rubber tires to increase pulling power · Remote control reversing · Exact reproduction of the Heusinger drive rod system · High reduction gears · Three working headlights on each end · Plastic body with black boiler, dark green cab and side tanks, window frames and hand rails brass · Cab doors open and close · Fully detailed die cast metal frame · Automatic couplers and working sprung buffers on each end · Length: 12"

new
5702



Diesel Locomotive

5720 DIESEL LOCOMOTIVE · A model of an industrial locomotive · 0-6-0 wheel arrangement · 2 special adhesion tyres · Automatic control for forward and reverse operation · High reduction gears · Three working headlights on each end · Red plastic body with two lengthwise yellow stripes · Cab doors open and close · Windows have inset plastic frames · Fully detailed die cast metal frame · Automatic couplers and working sprung buffers on both ends · Length: 12"

5720



60041

MOTOR BRUSHES for No. I Gauge Locomotives

Freight Train Set 5500

Train Set - No. I Gauge



5500

5500 FREIGHT TRAIN (without transformer) · With Tank Locomotive 5700, 1 open gondola car 5850, 1 dump car 5859, 2 straight track 5900, 12 curve track 5921 and 1 current feeder connector 5601 · Length of train: 40"

Use the MÄRKLIN group 6100 transformer to operate your No. I Gauge Railroad.

Passenger Cars with Interiors

5801



5800



5801 PASSENGER COACH · 4 wheeled · Modeled after a coach from the Königlich Württemberg Railway · With platforms and working doors on each end · Coach body dark green · Grey roof with dark weathering · Simulated roof ventilators · Plastic windows inset in frames · Interior fittings include simulated wooden benches · Length: 12 1/4"

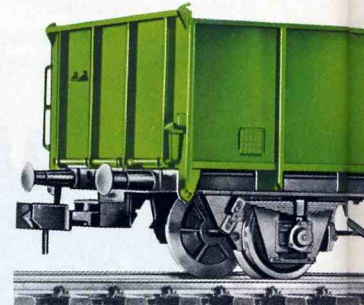
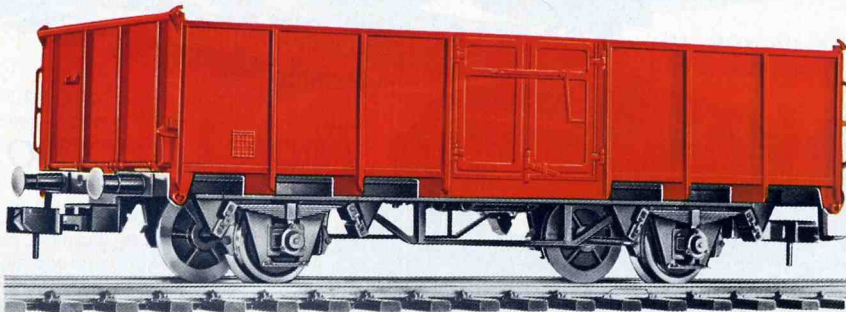

Gondola Cars

5855

5855 OPEN GONDOLA · 4 wheeled · Car body orange · Black underframe · Length: 12 1/4"

5851

5851 OPEN GONDOLA CAR · 4 wheeled · Model of the Belgian State Railways' (SNCB) truck · Green car body · True to prototype lettering · Black frame · Length: 12"

5850

5850 OPEN GONDOLA CAR · 4 wheeled · Model of the German Federal Railways' Type Omm 55 · Brown car body · True to prototype lettering · Black frame · Length: 12"

Relationship of sizes:
No. I Gauge HO Gauge

45 mm (1 3/4") 16.5 mm (5/8")

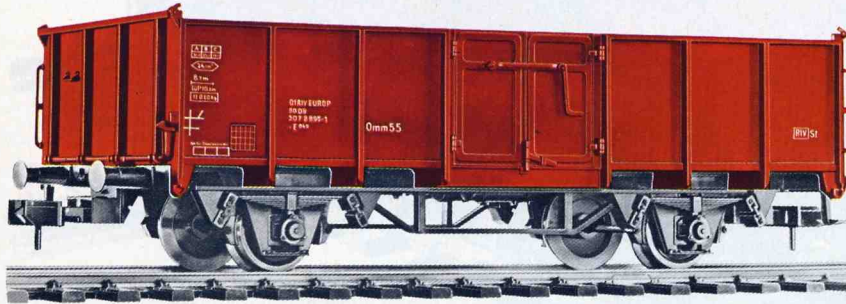
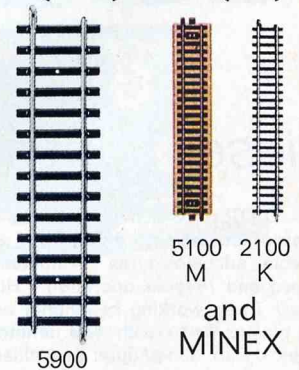

Use the MARKLIN group 6100 transformer to operate your No. I Gauge Railroad.

5520

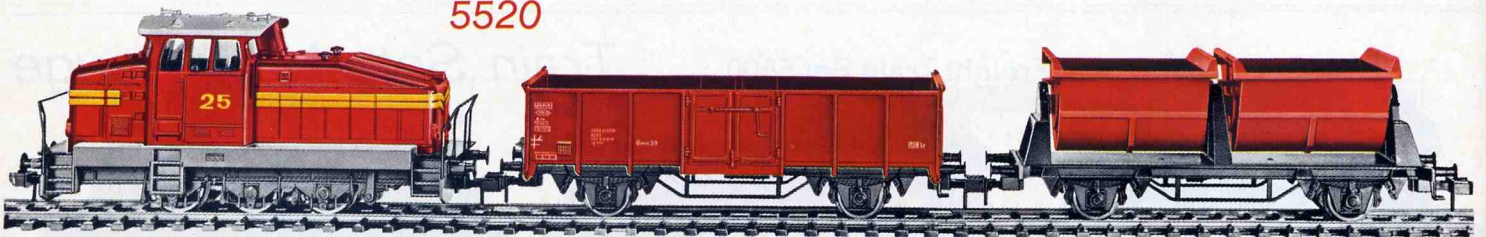

5520 Gift Box

5520 FREIGHT TRAIN (without transformer) · With diesel locomotive 5720, 1 gondola car 5850, 1 dump car 5859, 2 straight track 5900, 12 curved track 5921 and 1 current feeder connector 5601 · Length of train: 40"

5521 FREIGHT TRAIN (without transformer) · With diesel locomotive, 1 dump car 5859, 12 curve tracks 5941 and 1 current feeder connector 5601 · Length of train: 26"

5521



MÄRKLIN-No. I Gauge
2 Rail-A. C.

Scale 1:32



5800 PASSENGER COACH · 4 wheeled · Modeled after a private railway coach · With platform and working doors on each end · Coach body in beige and red · Grey roof with dark weathering · Simulated roof ventilators · Plastic windows inset in frames · Interior fittings includes simulated wooden benches · Length: 12 1/4"

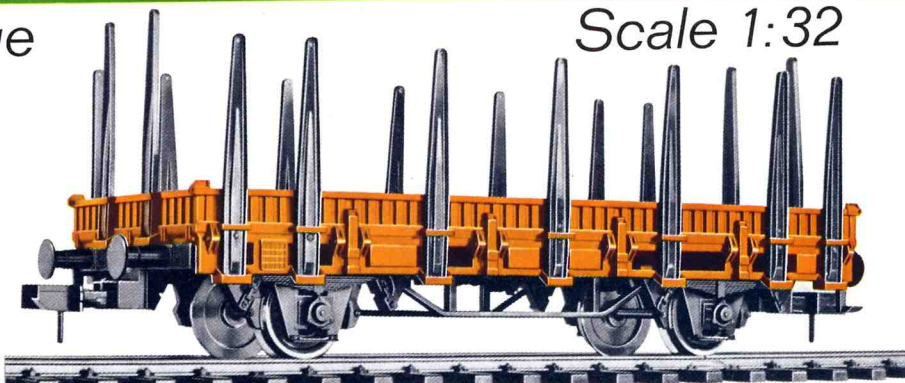

5853 FLATCAR · 4 wheeled · Car body yellow · Removable stanchions included with car · Black under-frame · Length: 12 1/4"

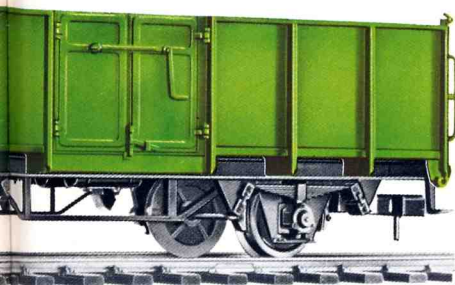

5856 OPEN GONDOLA · 4 wheeled · Car body lime green · Black underframe · Length: 12 1/4"

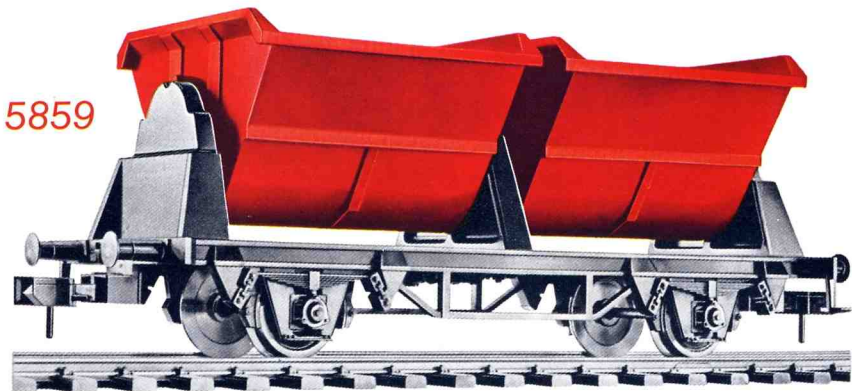

5859 DUMP CAR · 4 wheeled · 2 hoppers dump to either side, independent of each other · Latch holds hoppers in center position · Hoppers red · Underframe black · Length: 12"

No. I Gauge Track

The running rails, mounted on plastic ties and insulated from each other, not only guide the wheels but supply current to the locomotive. The track sections are connected by rail joiners on each rail, plus a clip on the base of the plastic tie strip. The rails are made from solid stainless, non-rusting weather resistant metal, except for 5910 and 5941.

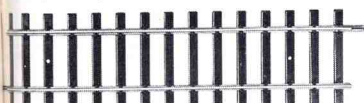

5900 STRAIGHT TRACK SECTION · 12" long

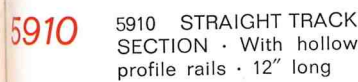

5910 STRAIGHT TRACK SECTION · With hollow profile rails · 12" long



5908 STRAIGHT TRACK SECTION · 3 1/4" long

5909 STRAIGHT TRACK INSULATOR · Use for electrical insulation of track sections · 3 1/4" long



5921 CURVED TRACK SECTION · 24" radius

5941 CURVED TRACK SECTION · With hollow profile rails · 24" radius



5966 RIGHT HAND MANUAL TURNOUT · Sprung switch points · Frog angle 30° · Radius of curved rails: 24" · Length of straight track: 12"

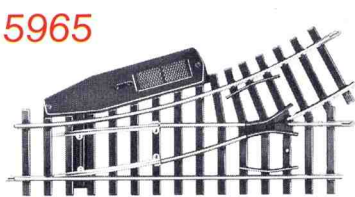

5965 LEFT HAND MANUAL TURNOUT · Sprung switch points · Frog angle 30° · Radius of curved rails: 24" · Length of straight track: 12"

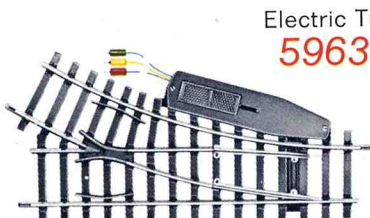

5963 RIGHT HAND TURNOUT, ELECTRIC OPERATION · With double solenoid · Sprung switch points · Frog angle 30° · Radius of curved rails: 24" · Length of straight track: 12"

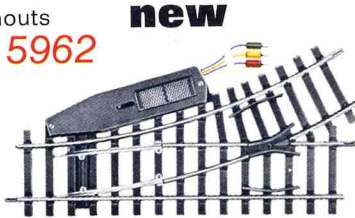

5962 LEFT HAND TURNOUT, ELECTRIC OPERATION · With double solenoid · Sprung switch points · Frog angle 30° · Radius of curved rails: 24" · Length of straight track: 12"

Electric Turnouts **new**

5603 CLIPS · 28 in a package · For connecting No. I track sections



5601 CURRENT FEEDER CONNECTOR · Consists of two metal clips which snap onto the track and two connecting cables · Cables are 39" long



5602 TRACK END BUMPER · Steel construction design · Sprung buffers · Black with red and white stripped buffer beam · Bumper clips onto rails · Length: 3 3/4"



5600 UNCOUPLER · Installed between the rails 5900 and 5910, this unit automatically uncomplex cars and locomotives · Length: 6 1/2"



The MÄRKLIN No. I Gauge trains operate with 16 volts A.C., the same as we use for our H0 scale trains. This provides you with all the many advantages you have come to enjoy with our smaller trains. The direction of the locomotive is changed only by switching the direction from the transformer. Although this train operates on the two rail system, there is no polarity problems because of the A.C. power. Reverse loops, crossings, or wye tracks offer no special problems.

We offer two distinct types of track: A hollow profile track for use on indoor layouts only; and a solid, stain resistant rail, mounted on thermal plastic ties for use either indoors or outdoors. Either type will give you a track system that is quite flexible in design and scale in appearance.

HO

The fascinating HO gauge train for operation in a small space, a true copy of the prototype

1:87



Minex

"O" Scale narrow gauge railway runs on HO track, a pleasure to operate, to collect and to admire

1:45

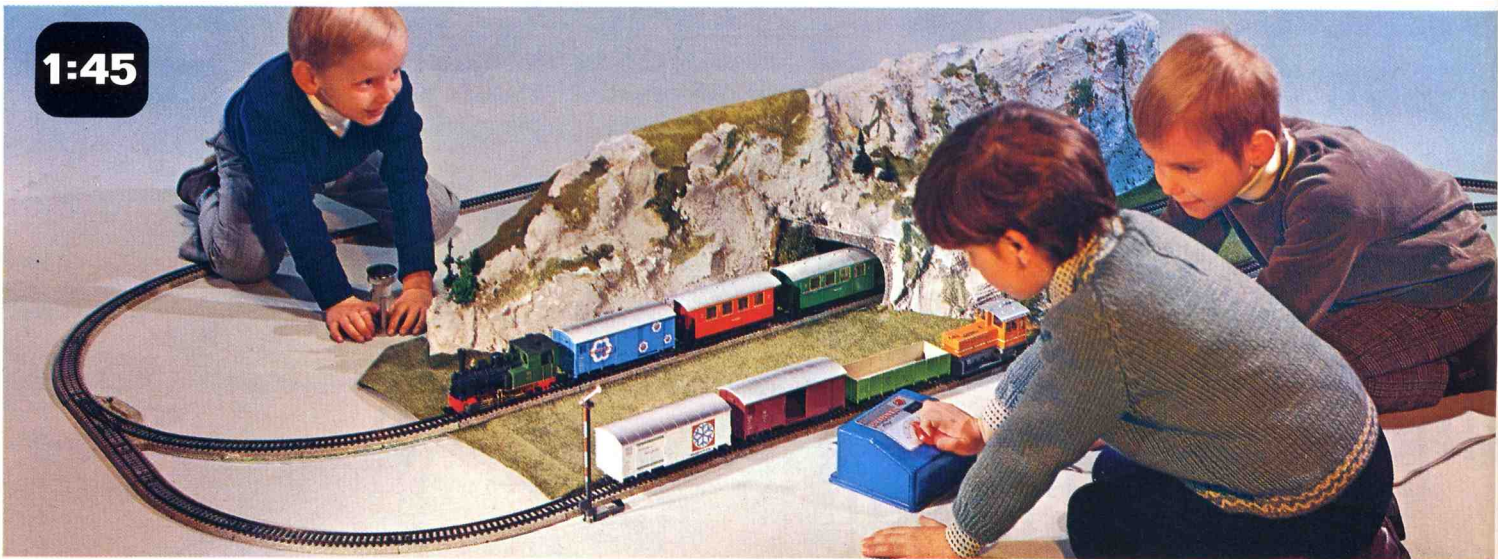

No. I

The big trains for indoor and outdoor fun

1:32

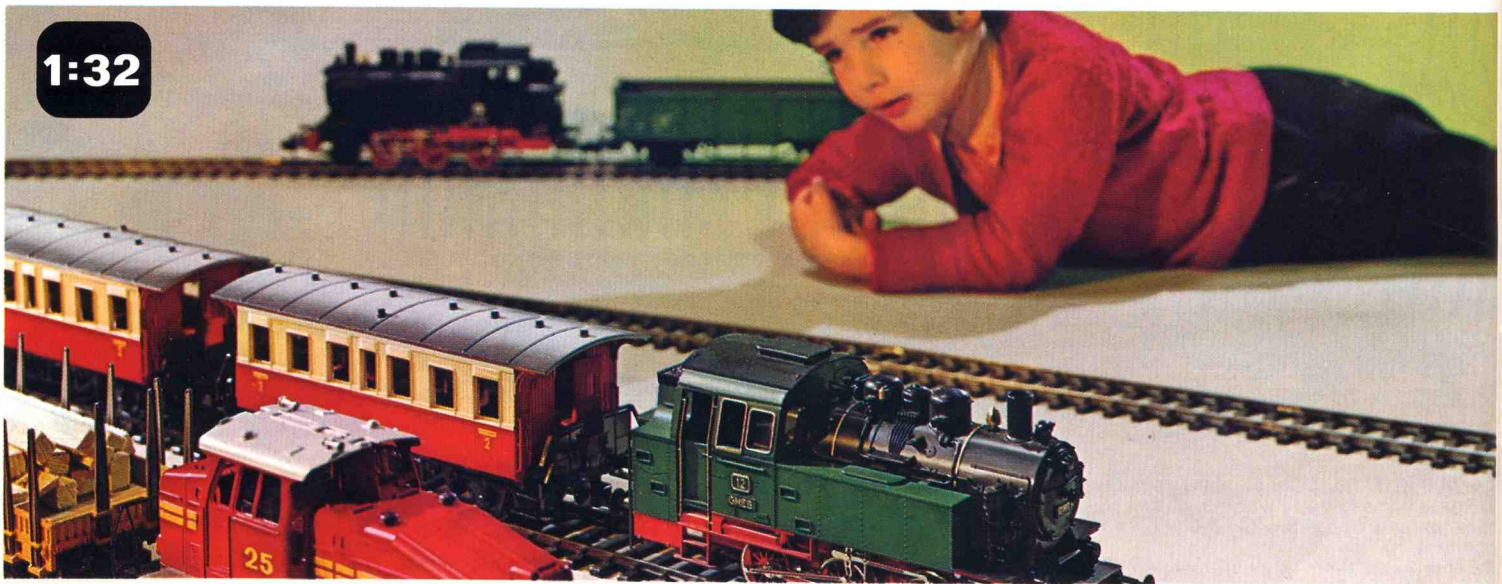

MÄRKLIN-Miniature Cars – Die Cast Metal with Working Parts

Each car has been designed to give you a collectors piece with the finest features and details possible. Doors, hoods and trunks open and close, the windows have clear plastic inserts, full interiors are provided and scale rubber tires complete these exquisite models.

Available for 1971

- 1800 Porsche 911 T Targa
- 1801 BMW 2000 CS Sport Coupe
- 1802 Chaparral 2 F Race Car
- 1803 Ford OSI 20 MTS Fast Back
- new 1804 BMW 2800 CS
- 1805 VW 1600 Variant Station Wagon
- 1807 VW 1600 Variant Fire Chief Car
- 1808 VW 1600 Variant Auto Club Car
- 1809 VW 1600 Variant Ambulance
- 1810 Porsche 910 GT
- 1811 NSU Ro 80 Wankel
- 1812 BMW 1600 Fast Back
- 1813 Mercedes C 111
- 1814 BMW 3000 Coupe
- 1815 Porsche 907 Race Car
- 1816 Matra M 530 Spider Coupe
- 1817 Mercedes 250 Sedan
- 1818 Chevrolet Corvette
- 1819 BMW 2002 ti
- 1820 BMW 2500
- 1821 Audi 100 LS
- 1822 Ford Capri 2300
- 1823 VW 1600 Variant Police Car
- 1824 Vacation Trailer
- 1825 VW 411 Sedan
- 1826 Porsche 914 Sports Car
- 1828 Mercedes 250 Police Car
- 1829 Mercedes 250 Taxi
- 1830 Unimog Truck with Flatbed
- 1831 Unimog Truck with Flatbed and accessories, 6 parts



MÄRKLIN *rak*

**–Pleasure around
the year**

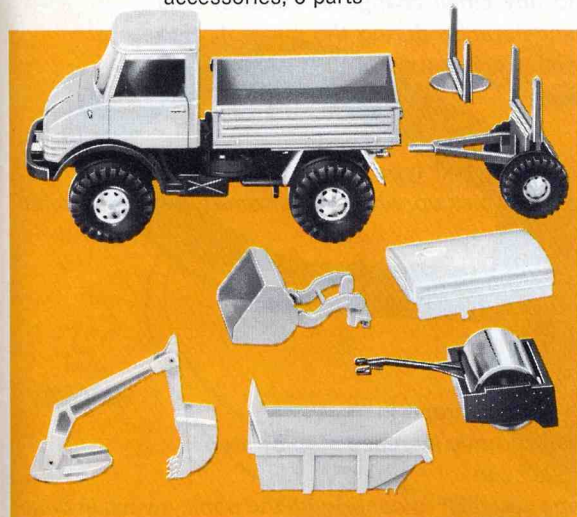

- 1832 Accessories for Unimog, 3 parts
- 1833 Accessories for Unimog, 3 parts
- new 1834 Audi 100 Coupe
- new 1835 Opel Manta 1900
- new 1837 VW K 70
- new 1838 Model Rally 1600 GT

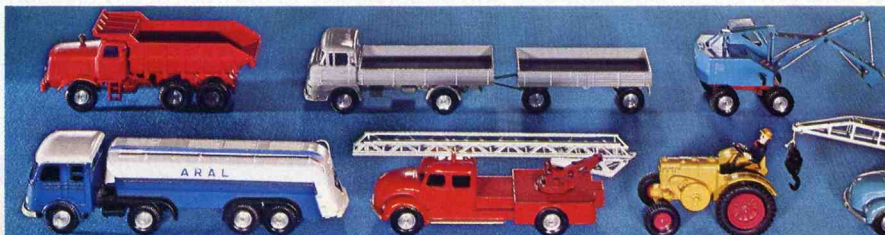

Ask your dealer for the special flyer which contains the complete collection of MÄRKLIN-Miniature Automobiles "rak"

The perfect home racing system

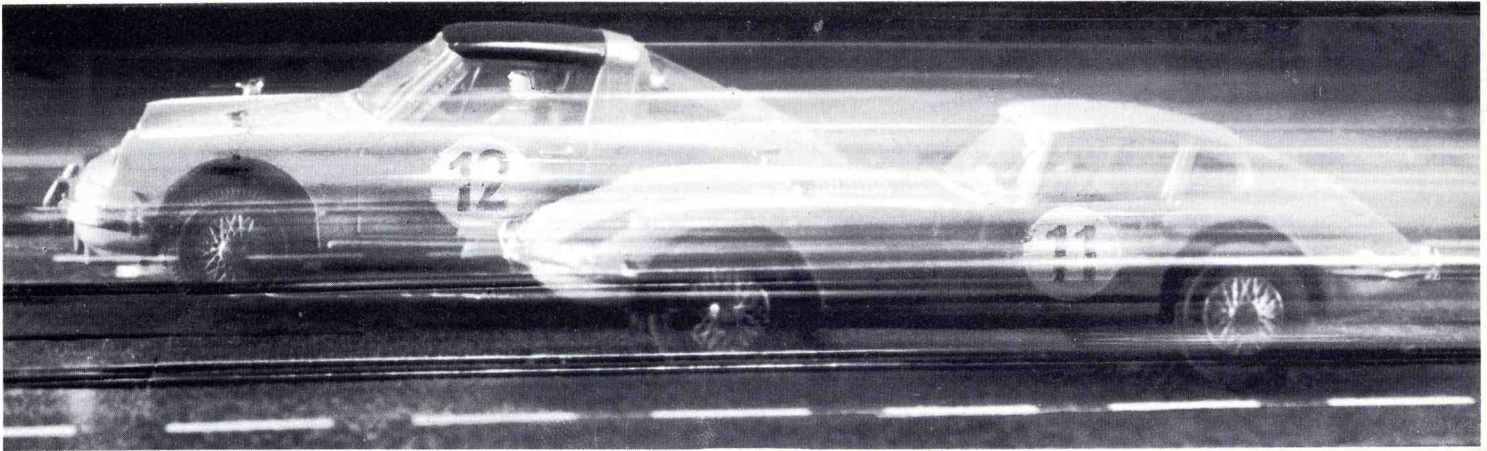
**1:32****MÄRKLIN**
Sprint

Built in the popular 1:32 scale, a minimum of space is required for the MÄRKLIN Sprint raceway. The track is designed to clip together very strongly for complete electrical and mechanical connection, yet goes together and comes apart with ease. No fussing around with track sections that do not fit and are hard to connect. Thus your track will stand up even under very long and hard usage.

Your race track can be built with two, four or six lanes, long straight aways, esses, banked curves, inclines, overpasses, chicanes, lane crossovers and many other exciting accessories including our reliable lap counter. Everything is available to build up almost any racing circuit and, wherever required, to safeguard all you tracks with strong crash barriers.

Every MÄRKLIN racing car is a miniature masterpiece. The high speed motor is located in the best position for correct center of gravity, providing good road holding ability. In addition, a special designed gear train is installed so that the car can respond to any small change in voltage. This means short, quick braking action before curves and immediate acceleration during the curve. It also gives you superior hill climbing ability on MÄRKLIN incline sections. Because of these many features, MÄRKLIN race cars can attain unbelievably fast lap times.

Another feature typical of the high MÄRKLIN quality is the solid ski type current pick up of the cars. They are sprung and are thus very reliable for current pick up, while at the same time they provide a cleaning action on the pick up rails.

The tires of the cars can be changed and adapted to the running characteristics of the track.

The speed controller can be operated without any steps in the speed regulation or it can be set to uniformly increase step by step.

Using the built-in key, the controller can be locked in a given voltage and then released with the panic switch in case



of emergency. The hand controller can be connected to the track at any location that is convenient to you.

A host of suggestions for building different exciting raceways are contained in the interesting MÄRKLIN Sprint Handbook. It also contains racing rules for many different types of races, always providing thrilling entertainment in your home, for all participants, young and old.

...competition all year MÄRKLIN

Gift Boxes

All of our sets come in beautiful gift boxes. Look for this colorful packaging at your dealer.

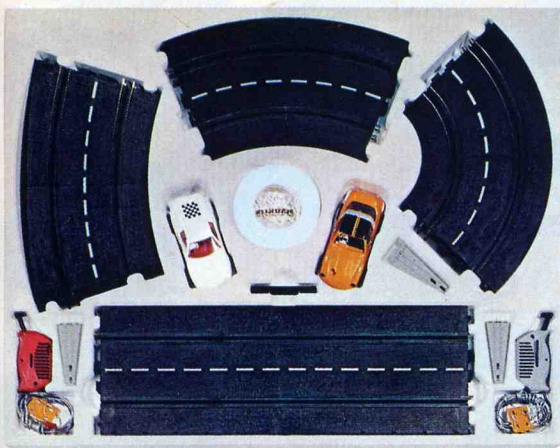

Running the lightning fast slot cars in the MARKLIN Sprint sets provides an exciting hobby quite different from our model railroads. Thus both hobbies compliment each other.



1400

34 1/2" x 17 3/5"

1400 RACING CAR SET, containing two formula racing cars, one Mercedes Monoposto and one Ferrari Supersqualo, two speed controllers, one red and one grey · Track sections: Four 1200 straight, four 1220 curved, together with crash barriers and 20 supports for them · These parts will make up an oval track · Full instructions are supplied with the Set

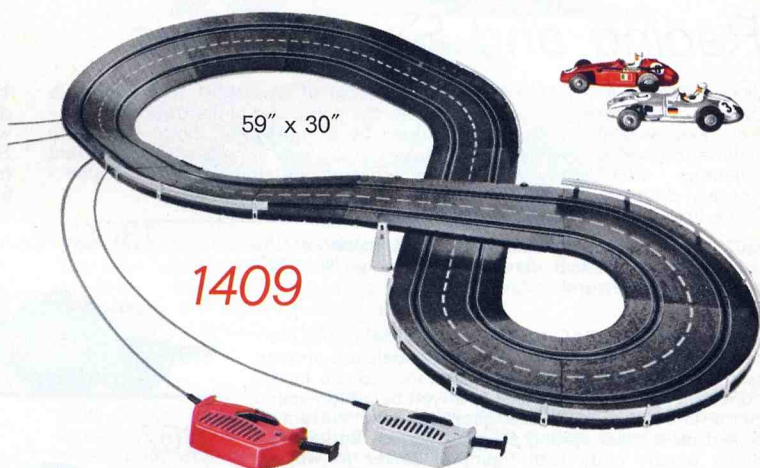

59" x 30"

1409

1409 RACE CAR SET WITH ONE BANKED CURVE · Contains two Formula 1 race cars, Mercedes Monoposto and Ferrari Supersqualo, 1 red and 1 grey hand controller, 2 straight track 1200, 2 straight track 1201, 2 straight track 1206, 3 curved track 1220, 2 curved track 1241, 4 1248 banked curved, guard rails, 19 guard rail posts, 3 clips, and 1 connecting section 1547 · A figure eight track with an overpass and a banked curve can be laid out with this material · Full instructions are supplied with the Set

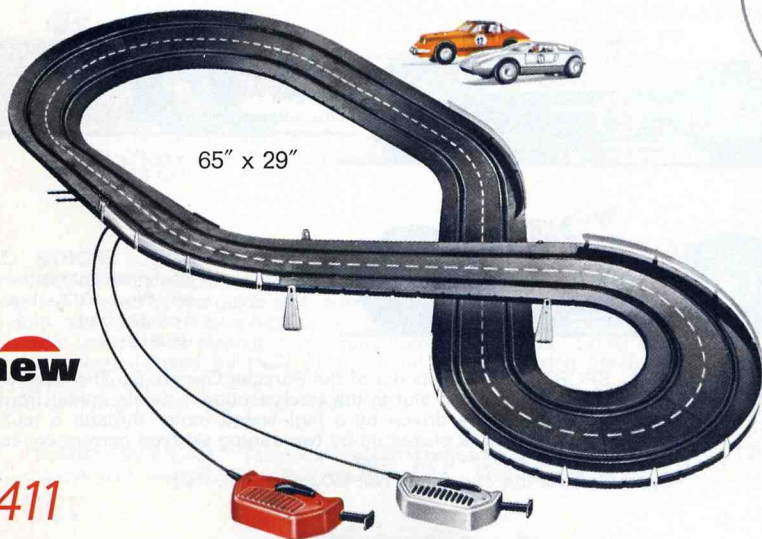

65" x 29"

new

1411

1411 RACE CAR SET WITH ONE BANKED CURVE · Contains 1 Porsche 911 Targa, 1 Mercedes C 111, 1 red and 1 grey hand controller, 2 straight track 1201, 2 straight track 1205, 2 straight track 1206, 3 curved track 1220, 2 curved track 1241, 4 banked curve 1248, 1 guard rail 78" long, 79 guard posts, 4 track clips, and connecting section 1547 · This makes a figure eight course with a banked curve at one end · Complete instructions are supplied with the set

- Pleasure around the year

Our larger racing sets



1405

96²/₅" x 39¹/₃"

91³/₁₀" x 30"

1405 RACING TRACK SET WITH ONE BANKED CURVE, containing a white Porsche Carrera 6 sports car and an orange-colored open sports car, with two speed controllers, one red and one grey · Track sections: Two 1200 straight, four 1201 straight, two 1205 straight, eight 1241 curved, four 1248 banked curved, two 1290 transfer sections to banking, two 1291 transfer sections from banking; one crash barrier 2 metres (6 ft. 6") long, one crash barrier 1½ metres (4 ft. 10½") long, thirty crash barrier supports, four 1547 joining sections and two clips · This material is sufficient to build up a figure eight track with an over-pass and one banked curve · Full instructions are supplied with the Set

Racing and Sports Cars

1306 FORMULA 2 RACING CAR · A model of the BMW 1600 with Lola chassis · The front wheels are steered by the guide slot in the track sections · Front axle assembly · The car is driven by a high-speed motor through a multi-ratio gearbox and current is picked up by two sprung ski-type current collectors · White body with blue underframe · Visible imitation engine · Figure of driver in white · 4½" long
Spare tires for this car: Front, No. 1503; rear, No. 1504

1307 FORMULA 2 RACING CAR · A model of the Lola-BMW · Technical details the same as No. 1306, but with red body and underframe

1300 FORMULA RACING CAR · A model of the Mercedes W 196 Monoposto · The front wheels are steered by the guide slot in the track sections · Scale model front axle assembly · The car is driven by a high-speed motor through a multiratio gear box and current is picked up by two sprung ski-type current collectors · Silver plastic body with figure of driver in white · 5" long
Spare tires for this car: Front, No. 1500; rear, 1501 or 1504



1301



1301 FORMULA RACING CAR · A model of the Ferrari Supersqualo · The front wheels are steered by the guide slot in the track sections · Scale model front axle assembly · The car is driven by a high-speed motor through a multi-ratio gearbox and current is picked up by two sprung ski-type current collectors · Red plastic body with figure of driver in white · 5" long
Spare tires for this car: Front, No. 1500; rear, 1501 or 1504

1313 SPORTS CAR · Technical details the same as No. 1302, but with open cockpit and windscreen · Silver body with black underframe · With figure of driver · 5 1/10" long

1313

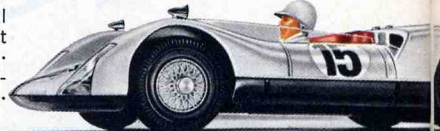

1306



1314

1307



1314 SPORTS CAR · Technical details the same as No. 1313, but with orange body and white underframe

1302 SPORTS CAR · A model of the Porsche Carrera 6 · The front wheels are steered by the guide slot in the track sections · Scale model front axle assembly · The car is driven by a high-speed motor through a multiratio gearbox and current is picked up by two sprung ski-type current collectors · White figure of driver · 5 1/10" long
Spare tires for this car: Front, No. 1500; rear, No. 1503

1302



1305



1305 SPORTS CAR · A model of the Porsche Carrera 6 · Technical details the same as No. 1302, but with red body

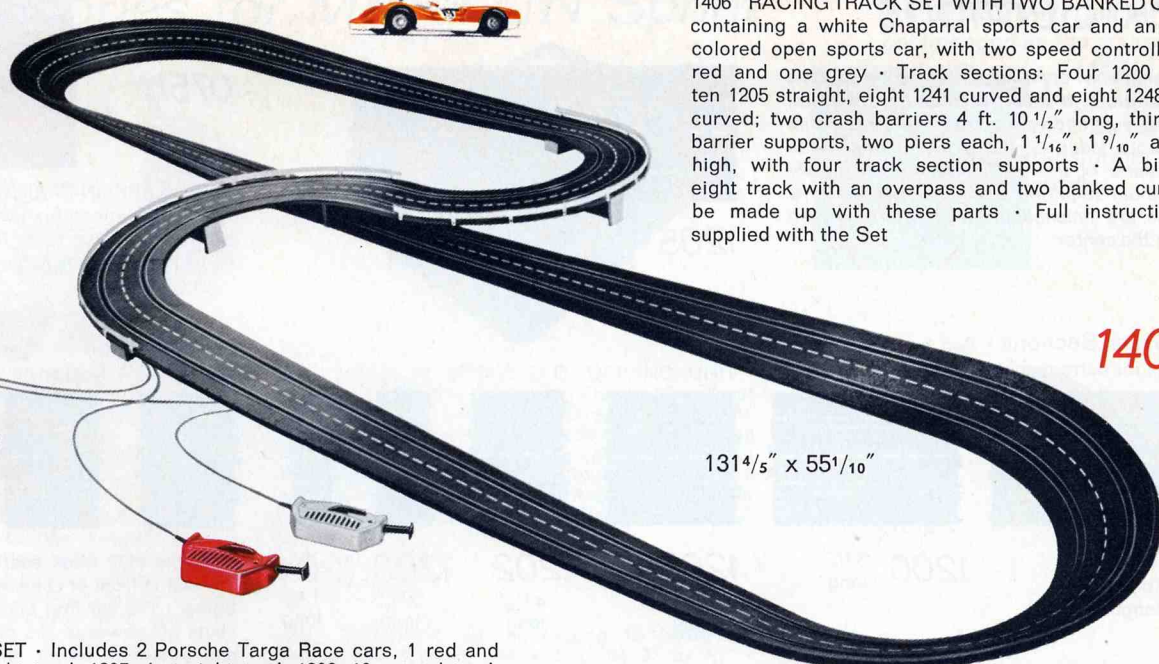

1406 RACING TRACK SET WITH TWO BANKED CURVES, containing a white Chaparral sports car and an orange-colored open sports car, with two speed controllers, one red and one grey · Track sections: Four 1200 straight, ten 1205 straight, eight 1241 curved and eight 1248 banked curved; two crash barriers 4 ft. 10 1/2" long, thirty crash barrier supports, two piers each, 1 1/16", 1 9/10" and 2 2/5" high, with four track section supports · A big figure eight track with an overpass and two banked curves can be made up with these parts · Full instructions are supplied with the Set

1406

131 4/5" x 55 1/10"

1410

1410 RACING TRACK SET · Includes 2 Porsche Targa Race cars, 1 red and 1 grey controller, 4 straight track 1205, 4 straight track 1206, 10 curved track 1241, 2 each piers 1 1/16", 1 9/10" and 2 2/5" high, 4 bridge railings, crash barriers and 50 supports for them · These parts will make a large figure eight track with an overpass · Full instructions are supplied with the Set

1315



1315 SPORTS CAR · A model of the Chaparral 2 E with vertical stabilizing fin · Front wheels are steered by the guide slot in the track sections · Front axle assembly · The car is driven by a high-speed motor through a multi-ratio gearbox, and current is picked up by two sprung ski-type current collectors · White plastic body with figure of driver in white · 4 1/2" long
Spare tires for this car: Front, No. 1500; rear, No. 1503

1308



1308 SPORTS CAR · A model of the E type Jaguar · Floating front axle · The front wheels are guided by the guide shoe · Scale model front axle assembly · Current is picked up by two ski like current collectors · Red plastic body with figure of driver · Length: 5 1/4"
Spare tires for this car: Front 1500, rear 1503

1310



1310 SPORTS CAR · A model of the Porsche 911 Targa · Floating front axle · Front wheels are guided by guide shoe · Scale model front axle assembly · Current is picked up by two ski like current collectors · Yellow plastic body with figure of driver · Length: 5 1/8"
Spare tires for this car: Front 1500, rear 1503

1316 GRAND PRIX CAR · A model of the Porsche Carrera 6 · The front wheels are steered by the guide slot in the track sections · Working front axle assembly · Car is driven by a high speed motor through a multi-ratio gearbox and current is picked up through two sprung current collectors · Silver plastic body · Cockpit enclosed by clear plastic hood · Two working headlights · With figure of driver · 5 1/8" long
Spare tires fitting model: Front 1500, rear 1503

1316

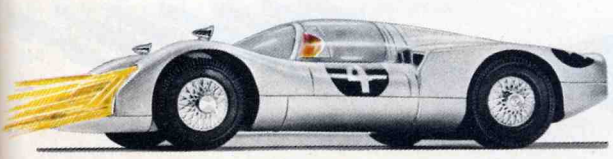

1317 GRAND PRIX CAR · Technical details the same as 1316 except for open cockpit with windshield · Red plastic body · With figure of driver · 5 1/8" long

1317

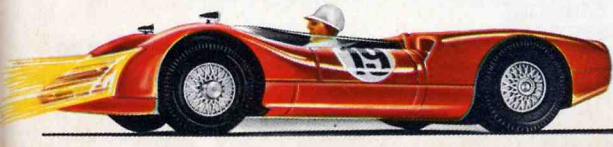

1311 SPORTS CAR · A model of the Mercedes C 111 · Front wheels steered by the guide shoe · Floating front axle · Sidewinder type motor mounting · All metal frame · Current is picked up by two ski like current collectors · Body white with black underframe · Length 4 3/4"
Spare tires for this car: Front 1500, rear 1503

1312 SPORTS CAR · Technical details the same as 1311 · Orange body

new
1311

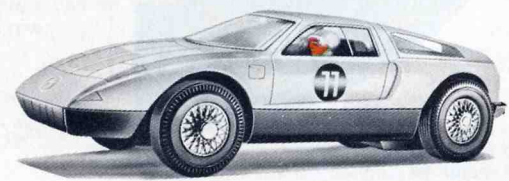

new
1312



Track Sections

All track sections are made of strong plastic material with slots in them for steering the cars, current being supplied to the cars by contact rails placed on both sides of the slots. Clip-in joints couple the parts of the track together absolutely securely without requiring any other connections. The sections are finished in black with a broken white line in the center.

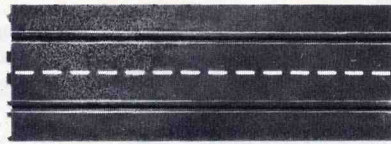

1205 16 3/4" long (double the length of 1200)

0751

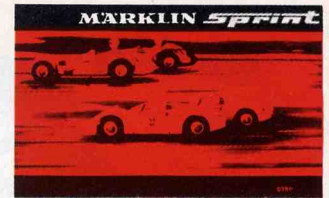

0751 MARKLIN-SPRINT RACING MANUAL · With suggestions for laying out racing circuits as well as giving rules for racing · Illustrated · 44 pages · 8 1/4" by 11"

Straight Track Sections · Two lanes with connections for current supply

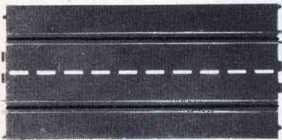

1206 12" long (double the length of 1201)

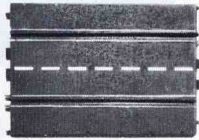

1200 8 1/3" long

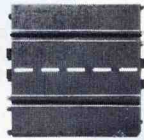

1201 6" long



1202 4 1/10" long

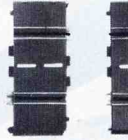

1203 2 2/5" long



1204 1 3/4" long

Track Section with Brake Action

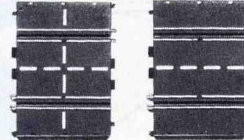

1207

Consists of 2 track sections each 4 1/8" long · For use in front of chicane tracks and crossover tracks · The car first entering this track section shuts off power to the other lane automatically and restores power only after leaving the contact section

Straight lane changing tracks

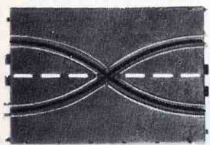

1217 Two lanes · The rails are insulated from each other · Length 8 1/3"

Change over lane sections can not be used individually, but must be used in pairs. This applies to sections: 1217, 1227 and 1247.

Chicane

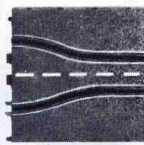

1216

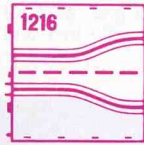

CHICANE · Two lanes · Track spacing reduced from 3" to 1 1/2" · Length 6" · TWO OF THESE CHICANE SECTIONS MUST BE USED

Curved Lane Changer



1227 CURVED TRACK SECTION 90° FOR CHANGING LANES · With two lanes · Mean radius 6"

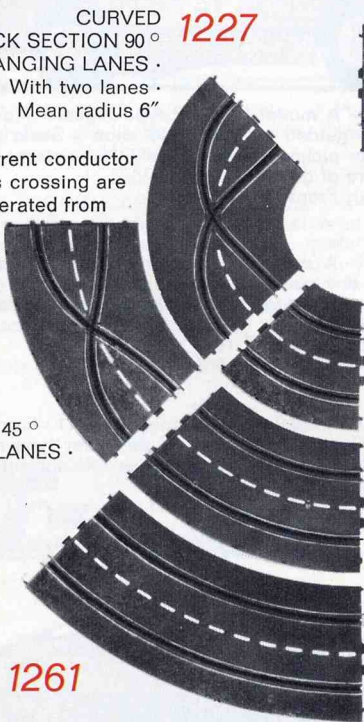

1247 CURVED TRACK SECTION 45° FOR CHANGING LANES · With two lanes · Mean radius 12"

Curved Track Sections

1261 CURVED TRACK SECTION 45° · Two lanes · Mean radius 18"

1290 STRAIGHT TRACK SECTION FOR START OF INCLINE · Concave slope; start and finish of the track form an angle of about 30° · Length 8 3/5"

1220 CURVED TRACK SECTION, 90° · Two lanes · Mean radius 6" · 1205, 1220, 1241, 1261 with connections for current supply

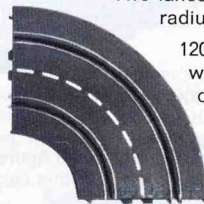

Curved Track Sections

1221 CURVED TRACK SECTION, 45° · Two lanes · Mean radius 6"

1241 CURVED TRACK SECTION, 45° · Two lanes · Mean radius 12"



1291 Incline STRAIGHT TRACK SECTIONS FOR FINISH OF INCLINE as 1290, but convex slope

Banked Curve 45°

1268

BANKED CURVE 45° · Two lanes · Mean radius 18"

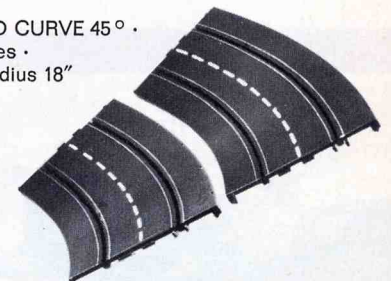

1248

BANKED CURVE 45° · Two lanes · Mean radius 12"

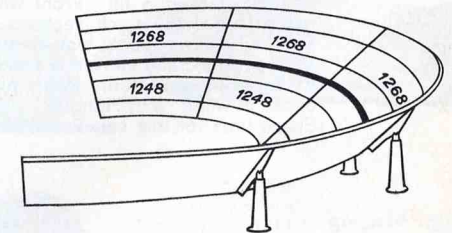

1546 BANK CURVE SUPPORTS · Contains: 7 width supports, three 5" high supports, four 3" high supports, and twelve connectors · Made of plastic · For use when widening banking to four lanes

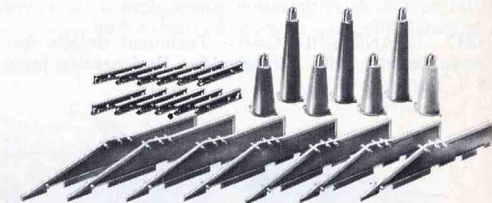

1546





Accessories for MÄRKLIN Sprint

1590



1591 ▶



6930



The 6930 Driving Unit is recommended as the source of current supply. If MÄRKLIN railway transformers are used the 1592 rectifier **must** be connected between the transformer and speed controller.

1590 SPEED CONTROLLER with connecting fittings · A very convenient shape, made of heat resistant plastic material · The push-type switch for setting the track current can be fixed by a ratchet stop to give any voltage required · An emergency stop push provides interruption of the current without altering the setting of the push-type switch · The color of the controller casing is grey · The connecting fittings consist of the connecting plate with a two-core cable 4 3/4 ft. long to the controller and another two-core cable 3 1/4 ft. long with a plug for connecting to the driving unit · A speed controller must never be used for more than one car at any time

1591 SPEED CONTROLLER, the same as No. 1590, but with a red casing

6930 MÄRKLIN SPRINT D.C. DRIVING UNIT · For use on 220 volts A.C. only · Output 10 watts at approximately 14 volts D.C. · Overload protection by an automatic current-limiting device · Connecting lead with sprayed mains plug connection · Blue sheet steel casing · On the output side there are two pairs of sockets marked "Auto 1" and "Auto 2" · Weight 2 lbs. 2 oz. · Size 5" by 3 7/10" by 2 1/10"

1592 RECTIFIER, for connecting to MÄRKLIN railway transformers · Size 2 1/5" by 2" by 3/5" · D.C. for running up to four cars at the same time can be taken from the pairs of plug sockets marked "Auto 1" and "Auto 2" · The transformer connected in series must have an output of not less than 16 watts

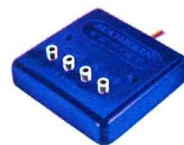

1592

1542

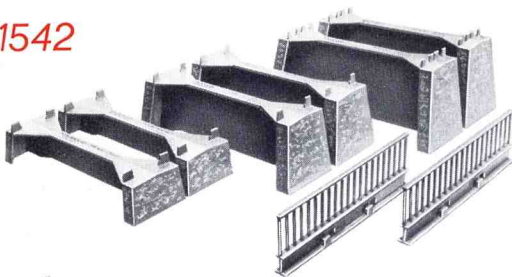

1543



1544



1541



1540



1547

1540 CRASH BARRIER, corrugated section plank-ing made of white flexible plastic · 6 1/4 ft. long

1541 SUPPORT FOR CRASH BARRIER, made of impact-resistant plastic for fixing crash barriers to the track

1542 CONSTRUCTION KIT FOR OVERPASS, consisting of two piers 1 1/16", two 1 9/10" and two 2 2/5" high, with two bridge railings · All parts made of grey plastic · For making up a very strong overpass that will even span four-lane tracks

1543 SUPPORT · 2 2/5" high · Made of grey plastic, with stubs on top face for fixing track sections

1544 BRIDGE RAILINGS for reinforcing overpasses · 5 3/10" long · 1 1/2" high · Made of grey impact-resistant plastic

1545 MECHANICAL LAP COUNTER, permanently mounted on a two-lane track section 4 1/10" long · The instrument reads up to 99 laps for both lanes in both directions, and the dial can be reset by hand · 5 1/10" high · 6" wide · On tracks having several lanes a number of lap scorers can be set up directly next to one another in a row

1547 CONNECTING SECTION · 2 9/10" long, plastic · For connecting two adjoining straight track sections and reinforcing the joints

Mechanical Lap Counter

1545



REPLACEMENT TIRES

1500 Set of 2 tires
20,5 x 6 mm
for 1300, 1301, 1302, 1305,
1308, 1310, 1311, 1312, 1313,
1314, 1315, 1316, 1317

1501 Set of 2 tires
23 x 7 mm
for 1300, 1301

1503 Set of 2 tires
20,5 x 7,6 mm
for 1302, 1305, 1306, 1307,
1308, 1310, 1311, 1312, 1313,
1314, 1315, 1316, 1317

1504 Set of 2 tires
24 x 8,4 mm
for 1300, 1301, 1306, 1307

MOTOR BRUSHES

60146 Set of two brushes
for the motors of MÄRKLIN Sprint
cars

EXTRA CURRENT PICK-UP SHOES
1510 (one pair) for attach-
ing to the pick-up shoes of MÄRK-
LIN Sprint Cars so that they can be
run on tracks of other makes

Important! MÄRKLIN SPRINT Racing Cars will only run on D. C. – direct current.

The Construction Sets for Fun

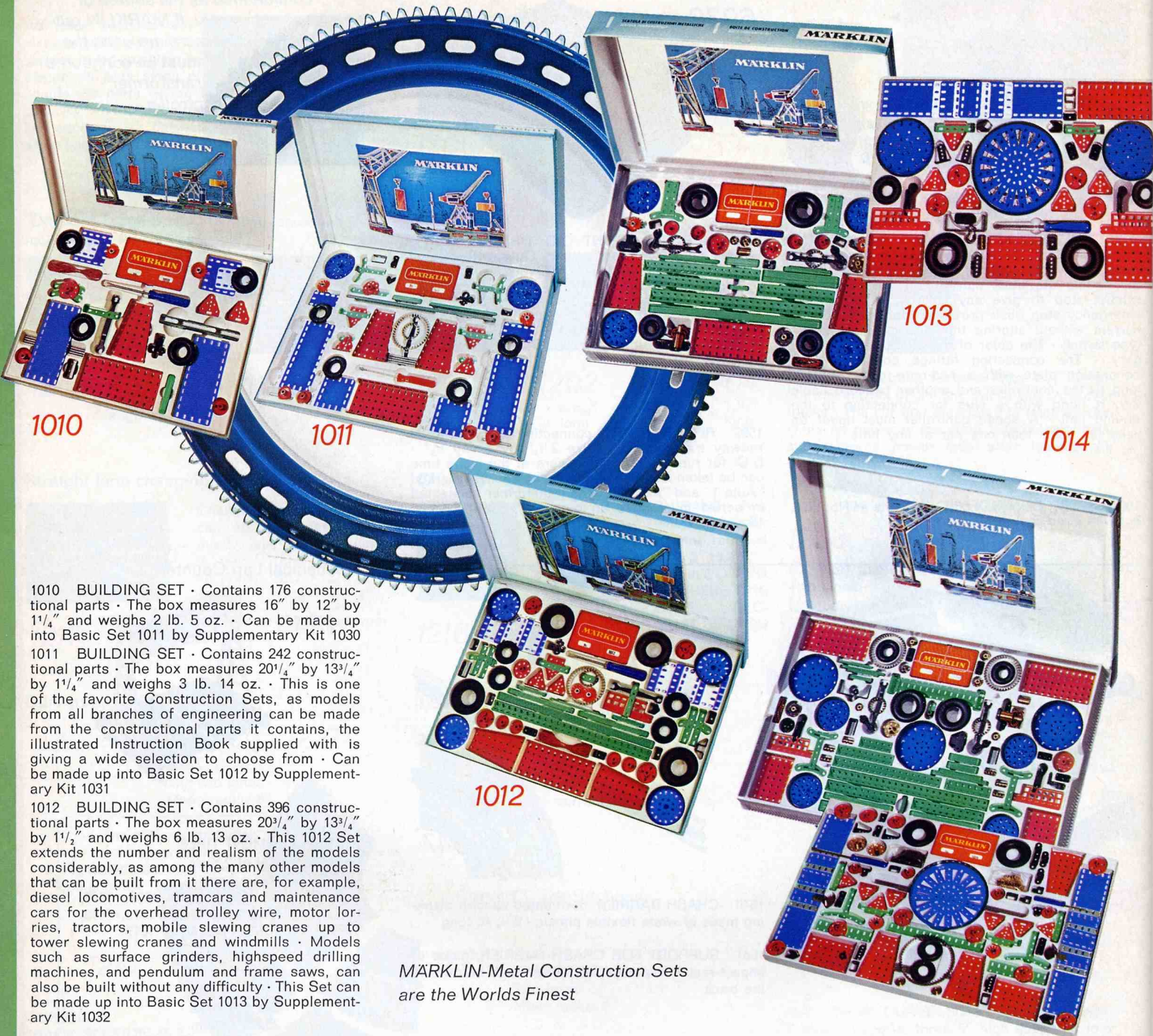

1010 BUILDING SET · Contains 176 constructional parts · The box measures 16" by 12" by 1 1/4" and weighs 2 lb. 5 oz. · Can be made up into Basic Set 1011 by Supplementary Kit 1030

1011 BUILDING SET · Contains 242 constructional parts · The box measures 20 1/4" by 13 3/4" by 1 1/4" and weighs 3 lb. 14 oz. · This is one of the favorite Construction Sets, as models from all branches of engineering can be made from the constructional parts it contains, the illustrated Instruction Book supplied with it giving a wide selection to choose from · Can be made up into Basic Set 1012 by Supplementary Kit 1031

1012 BUILDING SET · Contains 396 constructional parts · The box measures 20 3/4" by 13 3/4" by 1 1/2" and weighs 6 lb. 13 oz. · This 1012 Set extends the number and realism of the models considerably, as among the many other models that can be built from it there are, for example, diesel locomotives, tramcars and maintenance cars for the overhead trolley wire, motor lorries, tractors, mobile slewing cranes up to tower slewing cranes and windmills · Models such as surface grinders, highspeed drilling machines, and pendulum and frame saws, can also be built without any difficulty · This Set can be made up into Basic Set 1013 by Supplementary Kit 1032

MÄRKLIN-Metal Construction Sets are the Worlds Finest

Just a Few Reasons to Buy MÄRKLIN Metal

MÄRKLIN is synonymous with quality, and so what children are given to play with is not a matter for indifference—playthings that are accurately made will provide an education for accurate work in later life. Playing with these MÄRKLIN Metal Construction Sets will reveal and develop technical and creative talents even in the early years of youth. MÄRKLIN Metal Construction Sets are branded products of high quality; they can be had in five Basic Sets and five Supplementary Kits. MÄRKLIN Supplementary Kits enable each Basic Set to be made up into the next larger Set following. Each Basic Set contains a large assortment of constructional parts with an illustrated instruction Book showing numerous interesting examples. A number of very instructive models can be built with even the smallest Set. All parts in the Sets are made of best materials and enamelled in colors. All gear wheels—except the universal gear have machinecut teeth and turned bosses or hubs, instead of the stamped and riveted sheet metal parts so often used otherwise. Colored casings give the models a colorful appearance closely resembling the real thing. A great advantage is that these color plates can be bent at right angles and the lines of the bends then smoothed out again. Electrical parts such as commutators, field or magnet coils, cables etc, are also included in the assortment contained in Set 1013 and the following ones, so that an insight can be gained into the fundamental laws of electricity. The great variety of separate parts can be still further augmented by special parts obtainable from all shops selling MÄRKLIN Models and Sets.



and Learning

Supplementary Sets

Any Basic Set can be made up to the next larger one by a Supplementary Kit, the parts of the latter added to the existing Set forming the new larger Basic Set. If, for example, you have the 1010 Basic Set and want to make it up to the contents of Basic Set 1011, then you should get the 1030 Supplementary Kit.

- | | |
|----------------------------|---------------------------------------|
| Summarized: | |
| Supplementary Kit No. 1030 | makes up Set 1010 into Basic Set 1011 |
| Supplementary Kit No. 1031 | makes up Set 1011 into Basic Set 1012 |
| Supplementary Kit No. 1032 | makes up Set 1012 into Basic Set 1013 |
| Supplementary Kit No. 1033 | makes up Set 1013 into Basic Set 1014 |

Apart from the Supplementary Kits mentioned above, every MARKLIN Metal Construction Set can be expanded by extra parts if your Set does not contain sufficient of them for some model you wish to make. A separate list of these parts, as well as the actual parts themselves, can be obtained from every toyshop that deals in MARKLIN products.

1013 BUILDING SET · Contains 703 constructional parts · The box measures 20³/₄" by 14¹/₄" by 2⁵/₈" and weighs 11 lb. 11 oz. · This Set, and those following it, also contain electrical parts for making up motors that will really work · A "Short Course in Electricity" gives an introduction to electricity itself and its basic principles · This Set can be made up into Basic Set 1014 by Supplementary Kit 1033

1014 BUILDING SET · Contains 1006 constructional parts · The box measures 25¹/₄" by 16⁵/₈" by 2⁵/₈" and weighs 18 lb. 3 oz. · Hundreds of various parts give you more variety to build fascinating models · You also can build mechanical and physical models based on scientific methods · You can enlarge this set with 1034

1034

SUPPLEMENTARY SETS
Extends Basic Set 1014
a stage further



Electric Motors for use with Construction Sets

These motors can be used to power any models that have been with the MARKLIN Construction Set, and this will add much more pleasure and enjoyment to the model.

1071



1071 ELECTRIC MOTOR, reversible, to run either forward or backward · No-load speed about 1500 r.p.m. · Runs on 16 volts from MARKLIN model railway transformer · Supplied complete with two cables · 2¹/₂" high, 2" wide and 2" deep · Weight 7 oz.



1072

1072 ELECTRIC MOTOR to run on 16 volts, with cables and switch for reversing the running direction · Two cord or spring band pulleys running in opposite directions at different speeds controlled by the transformer · No-load speeds about 3000 and 1100 r.p.m. · An extremely efficient motor, suitable for driving the largest models made up from the Construction Sets, as well as working models of all kinds · (We advise using only a Group 6100 transformer) · With three connecting plugs · 2¹/₂" high, 3³/₄" wide and 2¹/₂" deep · Distance between pulley grooves 3¹/₂" · Weight 23¹/₂" oz.

Construction Sets

MARKLIN



MARKLIN

The number of Constructional Parts in MARKLIN Metal Construction Sets

Basic Set No.	Number of parts	Supplementary kit No.	Number of parts
1010	176	1030	67
1011	242	1031	164
1012	396	1032	308
1013	703	1033	307
1014	1006	1034	1100

... enjoyment
all year

MARKLIN

