

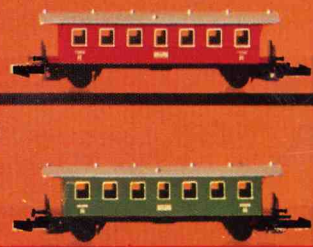

1972 E



MÄRKLIN



Contents:

mini-club 1-7 Train sets, locomotives, cars, tracks, accessories	Catenary system, HO gauge 56-57 For K + M tracks	Racing car track MÄRKLIN-Sprint 72-77
Trains sets, HO gauge 10-15	Transformers, HO gauge 64	Miniature cars „rak“ 78
Locomotives, HO gauge 16-33 Steam locomotives 16-20 Electric locomotives 21-27 Diesel locomotives 28-31 Rail buses/Rail motor trains 32-33 HAMO d. c. locomotives 17-33 Rubber tires, current pick-up, electric bulbs 61	Accessories, HO gauge 58-63 For K + M tracks 58-60 Additional locomotive accessories 61 Whistle 62 Lighting systems 62-63	Metal construction sets Electric motors 79-81
Cars, HO gauge 34-45 Passenger cars 34-40 Freight cars 41-45	Publications 65 Instruction manuals Track plans Signal manuals MÄRKLIN Magazine	It is not possible for the company to trade directly with private individuals. We reserve the right to introduce modifications without prior notice. Orders will be executed subject to availability. The dimensions quoted are given by way of information only.—This catalogue cancels all earlier issues.
Construction sets, HO gauge 36-46 Cars 46 Interior fittings 36		
Tracks, HO gauge 47-54 M tracks 47-50 K tracks 52-54	Minex 66-67 Locomotives, cars, accessories	
Signals, HO gauge 51/55 For M tracks 51 For K + M tracks 55 Universal remote control switch 51, 55	I Gauge 69-71 Locomotives, cars, accessories	GEBR. MÄRKLIN & CIE. GMBH. 732 GÖPPINGEN/WÜRTT. Registered trade mark 

All rights reserved · Reproduction in whole or part forbidden · Printed in Western Germany · Mohndruck Gütersloh · 151 10 - RN 0772 mo

YOUR LOCAL MÄRKLIN DEALER:

HOBBIES
 HOLLIN HALL SHOPPING CENTER
 7952 FT. HUNT RD.
 ALEXANDRIA, VA. 22308
 Phone (703) 765-9500

MÄRKLIN mini-club

The smallest
electric railroad
in the world

MÄRKLIN mini-club the big leisure time hit

Nothing like it has ever existed before. Never before has reality been presented in such fascinatingly small size and exciting detail. The track width of the smallest model railroad in the world is all of 6.5 mm ($\frac{1}{4}$ "), its tank locomotive is hardly longer than a match. Mini-club will conjure up a wonder world on your table, all in full view, which you can reach from your armchair. No basement is required, no suite of rooms and you do not have to be a do-it-yourself fan either. The mini-club is a true leisure time hit and makes an exciting hobby into a portable leisure time game.

Anyone with a soft spot in his heart will become an honest admirer of mini-club equipment. Each loco and each car model is a miniature of striking beauty and technical perfection. Even collectors of beautiful objects will enjoy owning these little gems. No matter whether you are presenting a mini-club collection to yourself, to a business friend or to your father-in-law—you will always make a "hit", since mini-club has what men like, the constantly attractive lure of what is neat and dainty. No picture and no photograph can convey the winning charm of this new game.

Why not see your mini-club dealer soon. Pick up one of these tiny models—and don't be surprised!

It will be love at first sight.

Here we have a mini-club loco and cars—the miniature railroad, made by master craftsmen, with the train travelling almost silently round the track, with the precision of a quality chronometer.

Clear the line for the new leisure time hit by MÄRKLIN!

NEW

Wonders in MÄRKLIN Quality



The maximum of pleasure in the minimum of space

mini-club, the smallest in the world, sets new, amazing standards. A model railroad "in your hand luggage" is no longer a dream. 12" x 21" is enough to set up a complete mini-club layout. Even a tea tray will do to serve up the magic of its remote-controlled models. Amazing possibilities are opened up. Your hobby kit can now quickly be put away under the table, or brought out from the cupboard, or hung on the wall like a picture. You can have ten minutes relaxation at any time just as easily as hours of pleasure in the evening, and in the living room, on the porch or terrace, or even in the home of friends. The handy

portable model railroad has become a fact. This is the most charming aspect of the smallest railroad in the world. All the fuss and bother is reduced to a minimum, mini-club is a game for lasting use, an absolute delight. Simply bring it out, connect it to the power supply and make complete escape the mini-club order of the day.

MÄRKLIN mini-club

Train Sets Locomotives

All you want to know at a glance

MÄRKLIN mini-club bears the track designation Z (6.5 mm = 1⁷/₆₄"). MÄRKLIN mini-club is DC-operated. Everything carrying the name mini-club is of renowned MÄRKLIN quality and is as hardwearing, reliable and efficient as any other model railroad made by MÄRKLIN.

The locomotives are fitted with suppressors, which, in conjunction with the anti-interference elements incorporated in the MÄRKLIN Power Pack 6720/6727/6731 and the feeder track section 8590, ensure that the Regulations are complied with.

If radio interference should arise during operation, e.g. because it is too close to an antenna, or because it has not been assembled as specified in the instructions, then the interference should be eliminated immediately, by moving the layout to some other place, or by modifying the layout.

8900 Freight train (without power pack) · Comprising tender locomotive 8800, beer car 8601, box car 8606, low-sided gondola 8610, tank

car 8612, 5 straight track sections 8500, 8 curved track sections 8510, feeder track section 8590 and ramp 8974 · Train 10" long



8901 Express train (without power pack) · Comprising diesel locomotive 8875, express coach 8720, express coach 8721, express diner

car 8723, 5 straight track sections 8500, 8 curved track sections 8520, feeder track section 8590 and ramp 8974 · Train 17 1/4" long



8800 Tank locomotive · A model of the 0-6-0 class 89 locomotive · 3 driven axles · Reversing by remote control · Mat black metal body · Die-cast zinc frame · Automatic coupling at each end · 1 7/8" long over buffers



8864 Diesel locomotive · A model of the German Federal Railways Class 260 0-6-0 locomotive · 3 driven axles · Reversing by remote control · Red metal body · Silver-coloured roof · Die-cast zinc frame · Automatic coupling at each end · 2" long over buffers



8875 Diesel locomotive · A model of the German Federal Railways' Class 216, 4-4 locomotive · All axles driven · Reversing by remote control · Three working headlights at each end, changing over with change in direction · Red and grey plastic body · Die-cast zinc frame · Automatic coupling at each end · 3" long over buffers

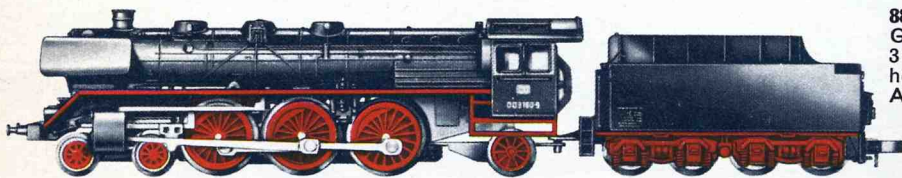

8885 Express locomotive with tender · A model of the German Federal Railways' class 003, 4-6-2 locomotive · 3 driven axles · Reversing by remote control · Three working headlights · Mat black plastic body · Die-cast zinc frame · Automatic coupling on tender · 4 1/8" long over buffers





8700 Passenger car · Platform and entrance at each end · Windows with cellopanes · 2³/₈" long



8701 Passenger car · Platform and entrance at each end · Windows with cellopanes · 2³/₈" long

8710 Express car · 1st class · A model of a German Federal Railways' car (A üm) · Windows inset in plastic frames · 4⁷/₈" long

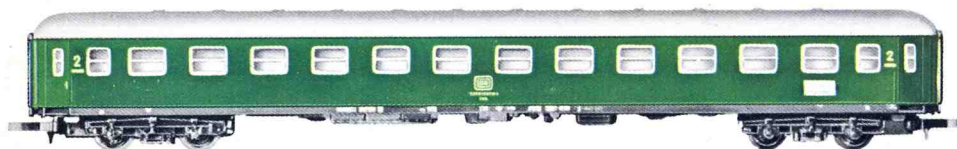

8711 Express car · 2nd class · A model of a German Federal Railways' car (B üm) · Windows inset in plastic frames · 4⁷/₈" long

8712 Express baggage car · A model of a German Railways' car (D üm) · Windows inset in plastic frames · 4⁷/₈" long

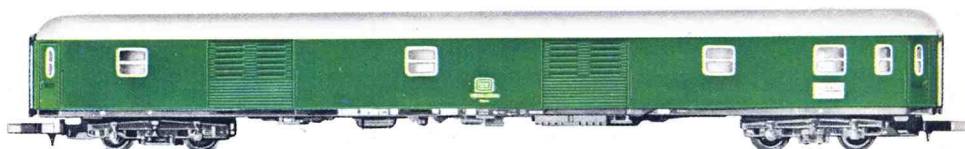

8713 Express diner car · A model of a German Federal Railways' car (WR üm) · Windows inset in plastic frames · 4⁷/₈" long

8720 Express car · 1st class · A model of a German Federal Railways' car (A üm) · Windows inset in plastic frames · 4⁷/₈" long



8721 Express car · 2nd class · A model of a German Federal Railways' car (B üm) · Windows inset in plastic frames · 4⁷/₈" long

8722 Express baggage car · A model of a German Federal Railways' car (D üm) · Windows inset in plastic frames · 4⁷/₈" long



8723 Express diner car · A model of a German Federal Railways' car (WR üm) · Windows inset in plastic frames · 4⁷/₈" long

MÄRKLIN mini-club

Freight Cars

8600 Refrigerator car · A model of a German Federal Railways' car (Ichqrs) · 2³/₈" long

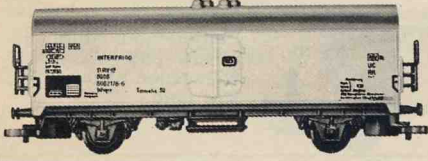

8601 Beer car · A model of a private car of the Dortmunder Union-Brauerei · 2³/₈" long



8602 Beer car · A model of a private car of the "Spatenbräu", Munich · 2³/₈" long



8605 Box car · A model of a German Federal Railways' car (Gbrs) · 2³/₈" long

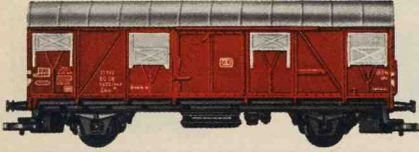

8606 Box car · A model of a German Federal Railways' car (Ibbls) · 2³/₈" long

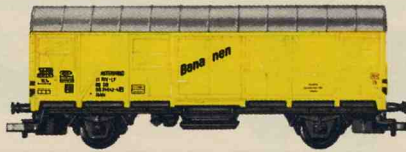

8610 Low-sided gondola · 2³/₈" long

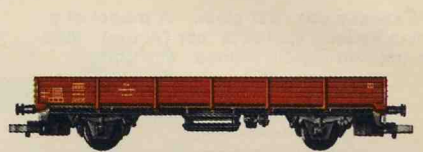

8611 Tank car · SHELL · 1⁵/₈" long



8612 Tank car · ESSO · 1⁵/₈" long



8613 Tank car · ARAL · 1⁵/₈" long



8615 Container car · DB · 2³/₈" long

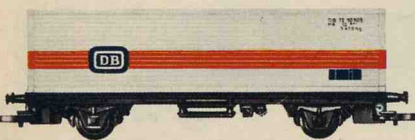

8616 Container car · Sealand · 2³/₈" long



MÄRKLIN mini-club bears the club package with the characteristic teak-wood pattern.



1 circle 8510 = 8 track sections
 1 circle 8520 = 8 track sections
 1 circle 8530 = 8 track sections

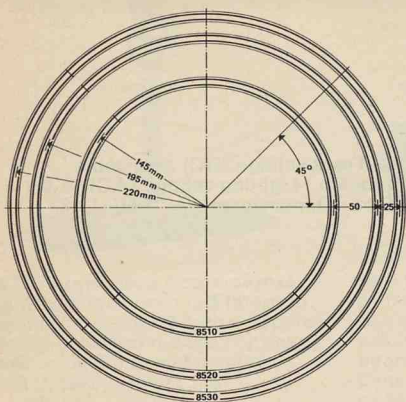

With a gauge of 6.5 mm ($\frac{17}{64}$ ") the overall width of the MÄRKLIN mini-club track sections is about 11.5 mm ($\frac{7}{16}$ "). The overall height is 2.5 mm ($\frac{1}{16}$ "). The solid, corrosion-resistant rails are mounted on a plastic tie strip. The rails are connected together by means of rail joiners, such as are also customary on larger models. An additional clip on the tie strip increases the strength of the track section joints. This drawing shows the three MÄRKLIN mini-club track circles with radius, track spacing and angle dimensions.

Straight track sections 8500 Length $4\frac{3}{16}$ "



8506 Length $4\frac{3}{16}$ "



8505 Length $8\frac{1}{4}$ "



Curved track sections

8510 Radius $5\frac{1}{4}$ " · 45°

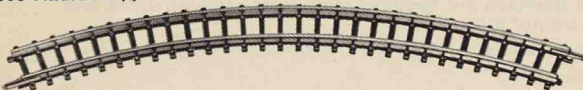

8520 Radius $7\frac{1}{4}$ " · 45°

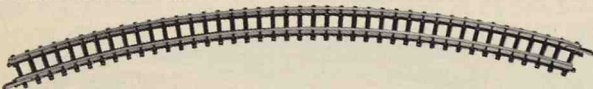

8530 Radius $8\frac{1}{4}$ " · 45°

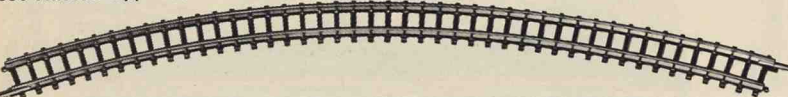

8591 Radius $19\frac{3}{16}$ " · 13°

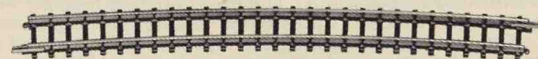

8559 Crossing · Angle 13° · Length of track sections $4\frac{3}{16}$ "

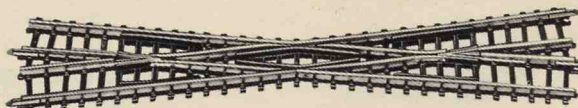

8561 Pair of solenoid controlled turnouts · Comprising one right-hand and one left-hand turnout, both with double solenoid operation · Additional manual lever · Angle 13° · Radius of turnout track $19\frac{3}{16}$ " · Length of straight track $4\frac{3}{16}$ "

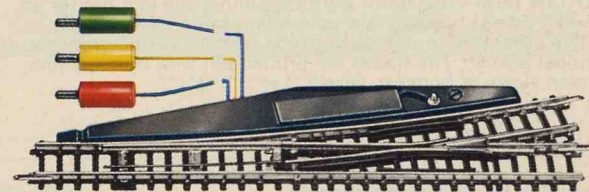
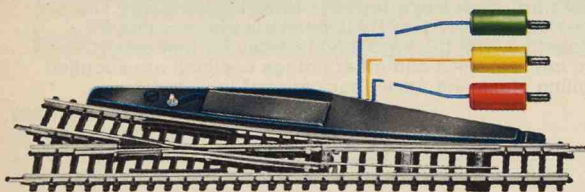

8564 Pair of manual turnouts · Comprising one right-hand and one left-hand turnout · Operated by hand lever · Angle 13° · Radius of turnout track $19\frac{3}{16}$ " · Length of straight track $4\frac{3}{16}$ "

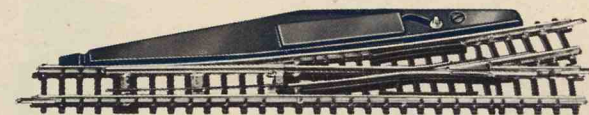
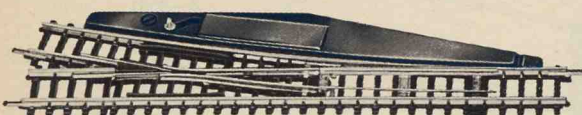

8590 Feeder track section, straight · With suppressor · 2 terminals for connecting the leads supplied with it · Length $4\frac{3}{16}$ "

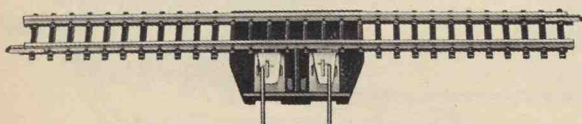

8598 Isolating track section, straight · With terminals · The rail next to the terminals has a break in the middle · Length $4\frac{3}{16}$ "

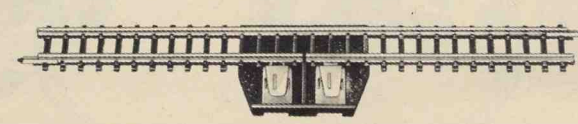

8597 Uncoupling track section · For uncoupling automatic couplings · Uncoupling ramp operated either through the built-in solenoid by remote control, or by hand lever · Length $4\frac{3}{16}$ "

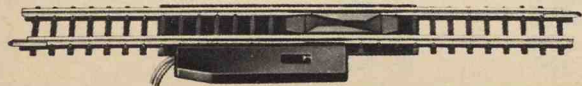

8599 Contact track section, straight · With terminals · For triggering switching operations by means of the passing train · Length $4\frac{3}{16}$ "



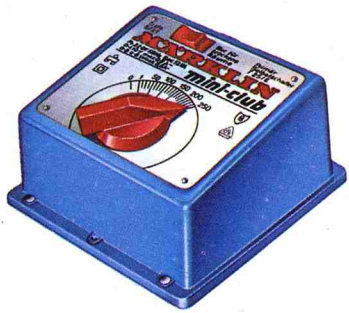

6720 = 100 volt for Japan
6727 = 115 volt for USA
6731 = 220 volt

DC power pack · Output 12 VA · Track voltage (DC) adjustable between 2 V and 8 V · Reversing switch · Lighting voltage (AC) 10 V · Blue plastic case · Weight 2 lb 10 oz · Dimensions 4¹⁵/₁₆" x 5⁵/₁₆" x 3"

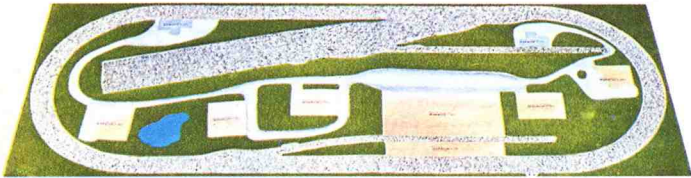

8910 MÄRKLIN mini-club Toporama · The true-to-nature model railroad landscape for an oval track with sidings · 4-color printing on synthetic paper · The printing shows the track layout with precise subdivisions, roads, paths, lakes and plan views of houses · Lichen-covered areas provide a sculptural effect · Size 1'7" x 4'1"

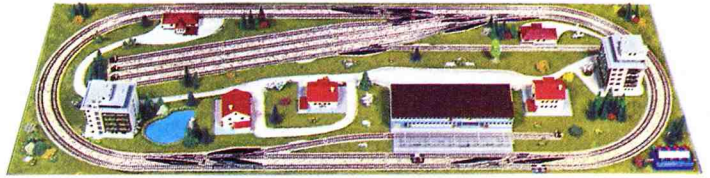

8920 MÄRKLIN mini-club Toporama—fully assembled · The Toporama 8910 is permanently mounted on a wooden base together with the track, and is ready for immediate operation · The houses, trees and other fittings depicted are supplied in kit form · Rolling stock and power pack are not included



8919 MÄRKLIN mini-club track layout · Landscape laid out for an oval track with sidings, printed in 4 colors on strong hardwearing material · The attractive arrangement of the landscape guarantees a pleasing model layout · The tracks are printed on, with roads, paths, lakes and plan views of houses · Size 1'1³/₄" x 3'3¹/₂"



8929 MÄRKLIN mini-club track layout—fully assembled · The MÄRKLIN mini-club track layout 8919 is permanently mounted on a wooden base together with the track, and is ready for immediate operation · The houses, trees and other fittings depicted are supplied in kit form · Rolling stock and power pack are not included

A few examples for designing layouts

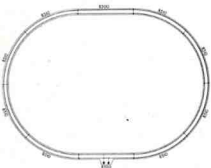

Fig. 1 1 ft. 6 in. x 1 ft. 1¹/₂ in.
1—8500
8—8510
1—8590

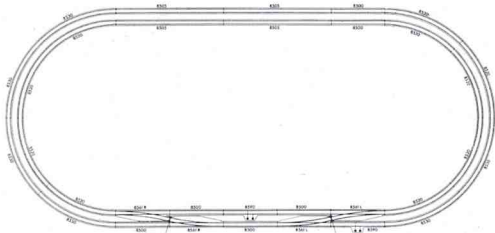

Fig. 3 3 ft. 5 in. x 1 ft. 7¹/₂ in.

6—8500 2—8561
4—8505 2—8590
8—8520 1—8951
8—8530

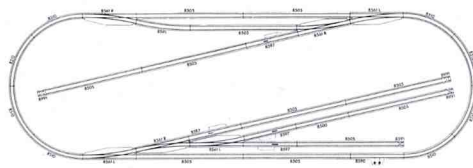

Fig. 2 3 ft. 7¹/₂ in. x 1 ft. 1¹/₂ in.

1—8500
11—8505
8—8510
3—8561
1—8590
1—8591
4—8597
4—8991

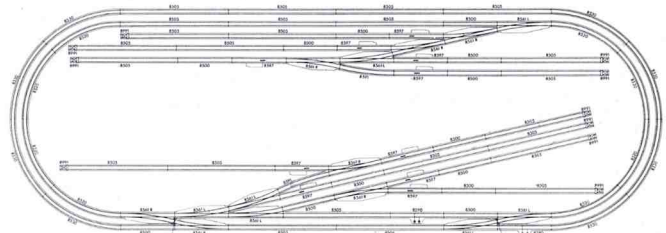
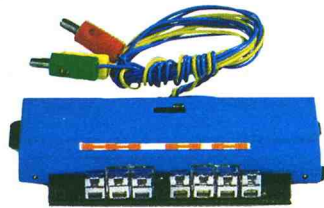

Fig. 4 4 ft. 6 in. x 1 ft. 7¹/₂ in.

13—8500 2—8590
24—8505 2—8591
8—8520 10—8597
8—8530 1—8951
7—8561 10—8991



8939 Illuminated home signal · Light changes from red (stop) to green (proceed) · 2 bulbs · Operated by universal remote controller 8945 or by the signal manual switch 8946 · Height 1 $\frac{3}{16}$ "



8945 Universal remote-controller with two single-pole switches and one change-over switch · Operating voltage 10 V · Double solenoid operation · Actuated by contact track sections, from a control panel or by means of an additional hand lever · Width 1 $\frac{3}{16}$ " · Length 2 $\frac{3}{4}$ " · Height $\frac{3}{16}$ "

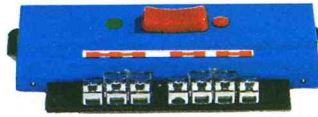

8946 Manual signal controller with 2 single-pole switches and one change-over switch e.g. for controlling the light changes in signal 8939 and the track current · Hand lever · Width 1 $\frac{3}{16}$ " · Length 2 $\frac{3}{4}$ " · Height $\frac{3}{16}$ "

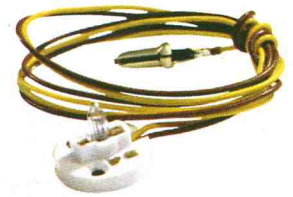

8950 Light socket with light insert and cable · For stations, buildings and the like



8951 Pack of 10 turnout isolating clips · Made of plastic · For electrical isolation of rails at turnouts



8953 Light insert · With bulb, 10 V · For use with light socket 8950 and for lighting locomotives



8974 Ramp · Made of plastic · Facilitates placing locos and cars on the track · Length 5 $\frac{1}{2}$ " · Height $\frac{1}{2}$ "



8991 Bumper · Clips on to rails · Black · Buffer beam, white with red stripes · Length $\frac{3}{8}$ "

8999 Track fixing nails · $\frac{1}{4}$ " long · Pack of 100 nails

8987 Pair of carbon brushes for locomotives 8800 and 8864

8988 Pair of carbon brushes for locomotive 8875

8989 Pair of carbon brushes for locomotive 8885



8960 Station building kit (Göppingen Station) · Modern design · Floor area 9" x 4 $\frac{1}{2}$ " · Height 1 $\frac{3}{4}$ " · Designed for mounting light socket 8950



8961 Platform building kit · In two parts · Overall length 17" · Width 1 $\frac{1}{2}$ " · Height 1"



8962 Station building kit (Dürnau Station) · Multi-purpose building with annex and loading ramp · Floor area 2 $\frac{3}{4}$ " x 2" · Height 1 $\frac{1}{2}$ " · Designed for mounting light socket 8950



8963 Building kit, apartment house with penthouse · The two top sections can also be used individually as a bungalow or a kiosk · Floor area 3 $\frac{3}{8}$ " x 3 $\frac{3}{8}$ " · Height 3 $\frac{3}{16}$ " · Designed for mounting light socket 8950

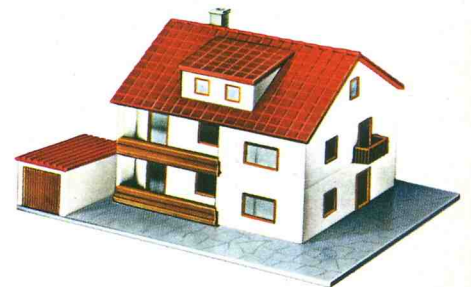

8964 Building kit, house with garage · Floor area 3 $\frac{1}{2}$ " x 2 $\frac{3}{4}$ " · Height 1 $\frac{1}{8}$ " · Designed for mounting light socket 8950

MÄRKLIN H0 Scale 1:87

All information given below concerning the H0 model railroad will be of interest to you.

(even if you already have one)

Irrespectively of whether your MÄRKLIN H0 model railroad layout is large or small there is always scope for new developments, extensions and improvements. Yet each stage is in itself complete and deeply satisfying. From the first single little train in a setting of toddler toys and cartons, up to the extensive layout of an enthusiast, equipped by using all of MÄRKLIN's ingenious techniques, in all cases the whole of the small or single layout can be fully integrated into the bigger or more elaborate

layout with nothing left unused. A model railroad offers infinite possibilities as a hobby, giving a chance to plan, design, invent and do-it-yourself, so that at any age, no matter whether you are 6 or 60, one can always come back to it and find something to do giving relaxation and pleasure.

The MÄRKLIN H0 model railroad offers special advantages inherent in the design philosophy:

1. Power supply via the central

conductor of the MÄRKLIN H0 track.

2. The exclusive use of alternating current for all parts of a MÄRKLIN H0 system.

The two together guarantee reliable Power supply to the locomotives and electric circuits which are easy to follow in even the most complicated layouts. Everything is easy to understand and is explained in addition in the instructions which accompany every item.

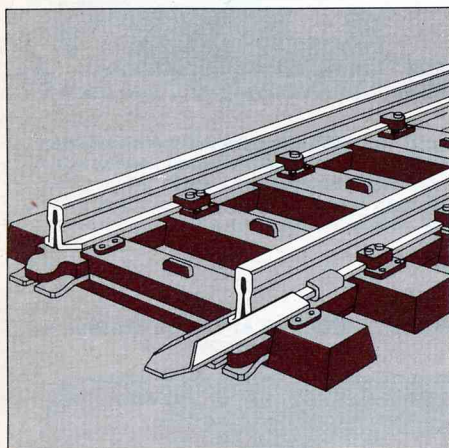

K track

Sixfold connection between track sections, comprising two rail clips, two sprung contacts on the central conductor and two couplings on the tie-strip.

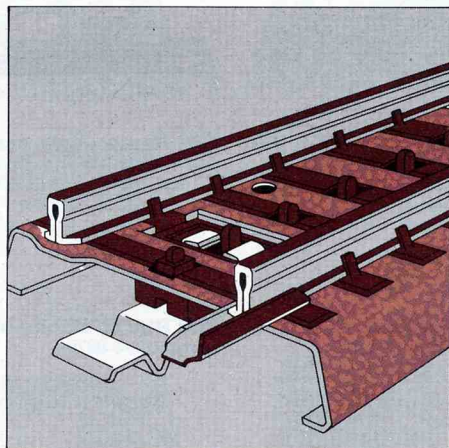

M track

Triple connection between track sections, comprising a sprung clip on the central conductor and two rail clips.

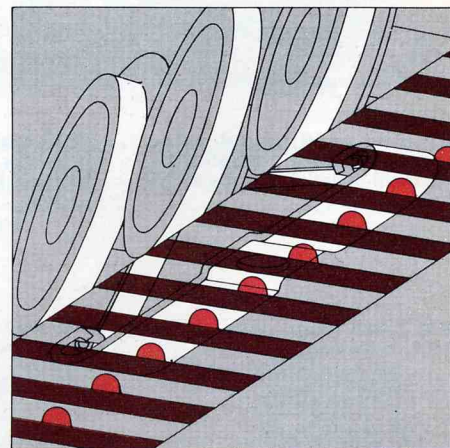

Reliable power supply

to the motor from the point contacts via the pick-up shoe. Return via the wheels of the locomotive.

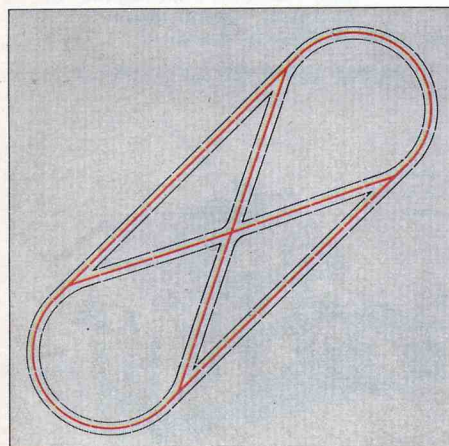

Easy to follow current path without intricate circuitry

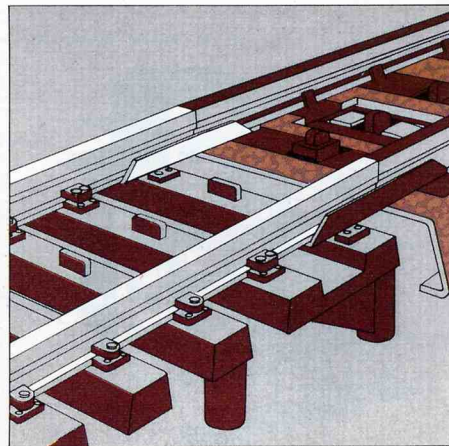

Adapter track sections

Used to connect metal tracks to plastic tracks.

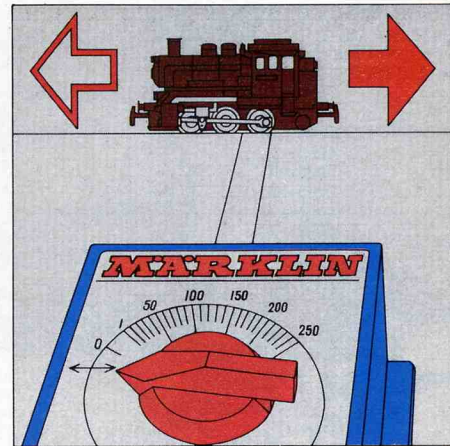

Reversing

of the locomotive by turning the control knob on the transformer to the left (overcurrent pulse).

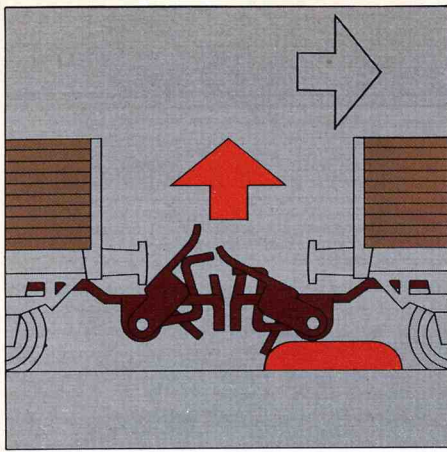

Automatic coupling

When the cars are brought into contact, the coupling automatically engages. At the uncoupling track, uncoupling can be carried out manually or by remote control.

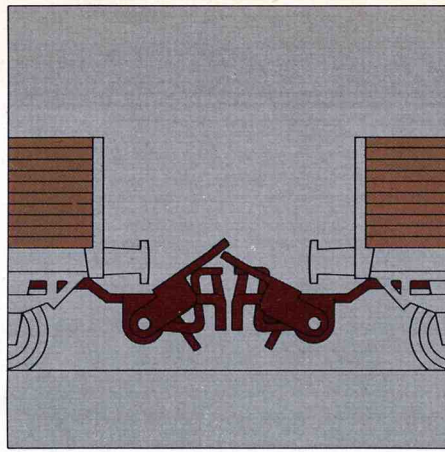

RELEX coupling

After uncoupling, the cars can be pushed for switching without the coupling re-engaging.

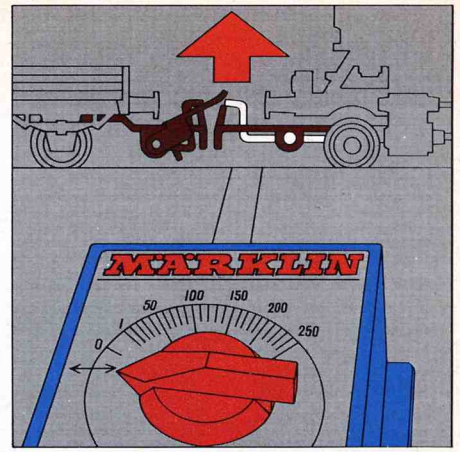

TELEX coupling

At any point in the layout uncoupling can be carried out by remote control from the transformer.

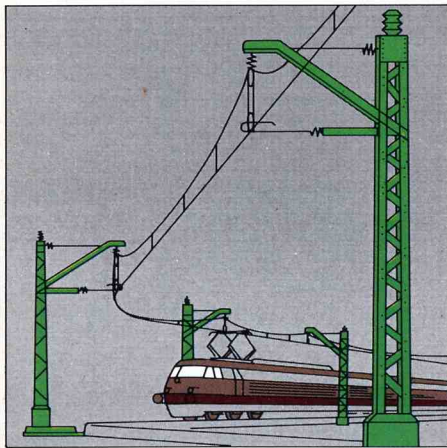

Catenary system

The masts are simple to set up and the contact wires easy to install. If the overhead conductor is wired up as a second circuit, two locomotives can be run independently of one another on the same track.

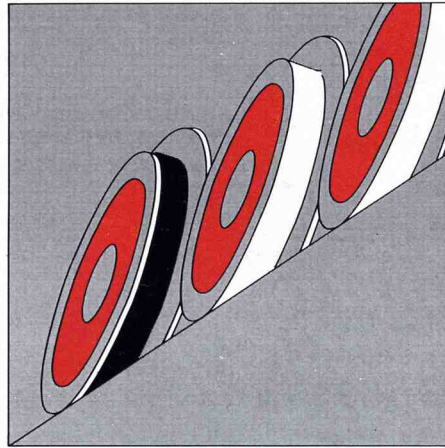

Rubber tyres

used on every locomotive, increase the pulling power by increasing the grip of the wheels on the rails.

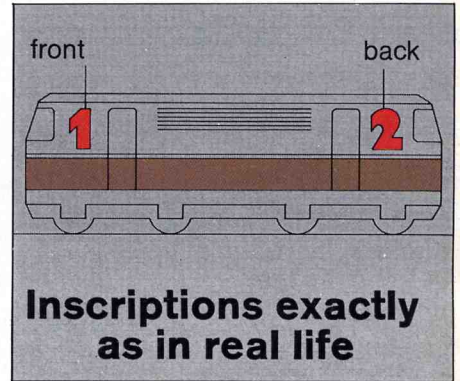

Inscriptions exactly as in real life

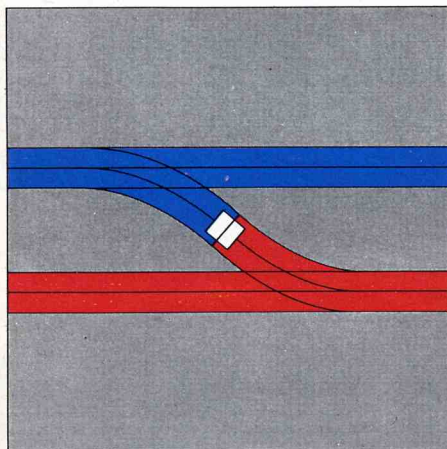

Circuit isolation

by means of a piece of cardboard. Isolating track sections are not required.

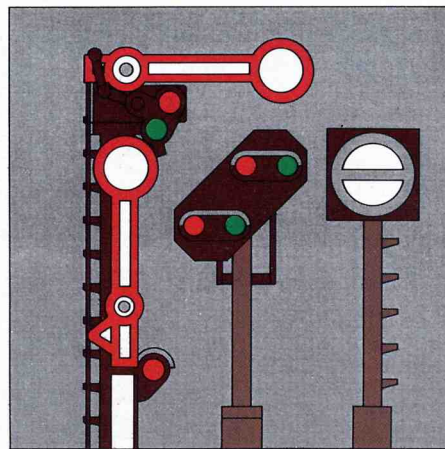

Signals

enable trains to be controlled fully automatically.

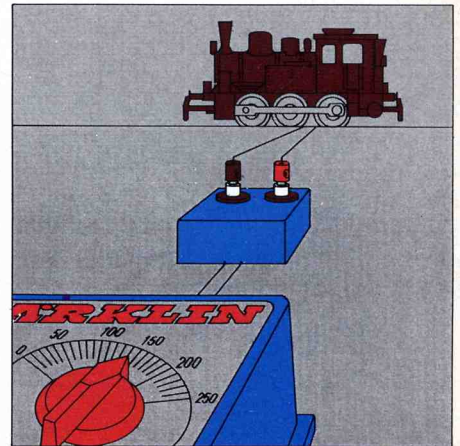

Interference suppression

All locomotives are fitted with condensers and choke coils to suppress radio interference. The incorporation of the suppressor bridge 7223 and the exclusive use of MÄRKLIN items, which are matched as regards their suppression effect, together with the MÄRKLIN transformer stated, guarantees that the statutory regulations on interference suppression will be complied with.



Train sets with oval track and transformer for train operating and lighting connection. Basic train sets which you can add to.

M **NEW**

- 2900** 100 Volt for Japan
- 2901** 110 Volt
- 2902** 110 Volt for USA
- 2905** 125 Volt
- 2909** 240 Volt for England
- 2911** 220 Volt
- 2914** 220 Volt for Finland

Passenger train with transformer
Consisting of locomotive, two passenger coaches, one straight track section 5106, one feeder track section 5111, eight curved track sections 5120 and one transformer · Train about 13 1/4" long

The transformers of these basic sets are not supplied separately.

The transformer supplied with these train sets, like all MÄRKLIN model railway transformers of the 6100, 6500 and 6600 groups, has connections for supplying current for trains and for lighting and magnetically-operated accessories. It also supplies high-voltage current for reversing the locomotives. This transformer will also operate larger locomotives or additional turnouts or signals. When overloaded or if the temperature rises too high, the transformer switches itself off automatically. **The transformers must be used only with alternating current**

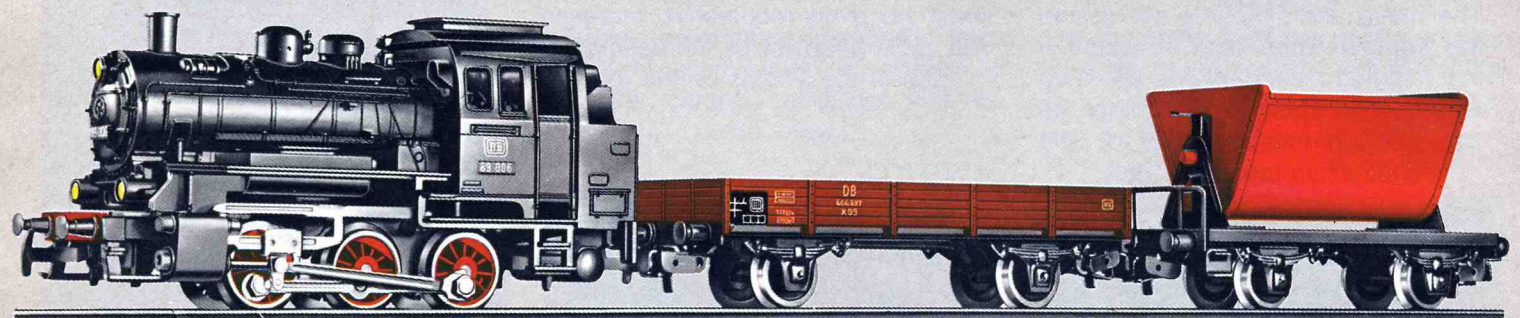

- 2960** 110 Volt
- 2961** 125 Volt
- 2963** 220 Volt
- 2965** 100 Volt for Japan
- 2975** 110 Volt for USA
- 2978** 220 Volt for Finland
- 2979** 240 Volt for England

M

- 2800** 110 Volt
- 2801** 125 Volt
- 2803** 220 Volt
- 2805** 100 Volt for Japan
- 2815** 110 Volt for USA
- 2818** 220 Volt for Finland

K

Freight train with transformer
With locomotive 3000, two freight cars, twelve curved track sections 2121, one straight track section 2100, one feeder track section 2190, two cables and one transformer · Train about 12 1/2" long

For enlarging the basic sets 2900-2914 and 2960-2979 we recommend the supplementary track sets 5090, 5091 and 5092 on

page 50 and for the basic sets 2800-2818 the supplementary track sets 2090 and 2091 on page 53.



5090



5091



5092



2090



2091

Accurate descriptions of these sets are given on pages 50 and 53

Freight train with transformer
With locomotive 3000, two freight cars, twelve curved track sections 5100, one straight track section 5106, one feeder track section 5111 and one transformer · Train about 12 1/2" long

Basic starter sets in gift boxes



Everything big starts by being small

Almost every large model railway layout was once small. Never forget that. Particularly for children, to "start small" is always right and proper. With a basic set you can make it considerably easier for yourself and your child to make a start on one of the most fascinating hobbies. Each of the three sets is complete with train, oval track and transformer with connection for supplying current to train and lights. Naturally it gives special pleasure if, right from the start, the trains can make a "long" run and if the cars can be switched. But this wish can be easily satisfied. All you need is a supplementary track set to expand the track layout.



MÄRKLIN H0





Train sets without transformer with oval track with full extension capability

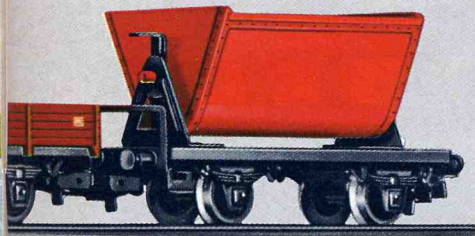

3200 M

3200

Freight train (without transformer)
With locomotive 3000, 3 freight cars, 11 curved track sections 5100, 2 straight track sections 5106 and 1 feeder track section 5103 · Train about 16 1/2" long

3203 M

3203

Freight train (without transformer)
With locomotive 3003, 3 freight cars, 11 curved track sections 5100, 2 straight track sections 5106 and 1 feeder track section 5103 · Train about 21" long

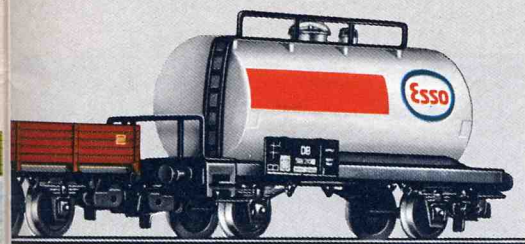

3183 K

3183

Freight train (without transformer)
With locomotive 3003, 3 freight cars, 12 curved track sections 2121, 1 straight track section 2100, 1 feeder track section 2190 and 2 cables · Train about 21" long

Connect only to an alternating current supply

The train sets are available in very attractive gift boxes.

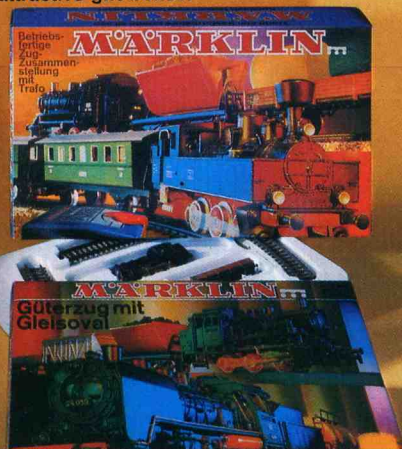

Gift boxes – a good idea

These bigger train sets not only have more cars and more track, they also have the advantage of being just as suitable for giving away as presents as for buying for oneself. What a good start on a bigger scale for example! The only extra purchase is one of the transformers (see page 64) and the set is immediately ready to run.

In choosing a supplementary track, you have not merely one, but several possibilities. That is another gratifying advantage. Amongst the sets 5090, 5091 and 5092 on page 50 and 2090 and 2091 on page 53 you will certainly find the right one to suit you.

Since these are bigger trains, an extra supplementary track set is highly recommended. This small outlay, considerably increases the fun to be got from the set. The pleasure grows in proportion to the length of the track.

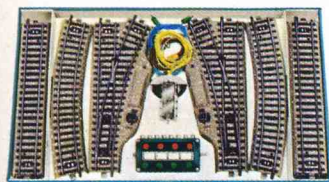

5090

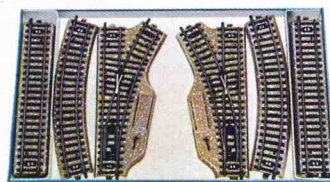

5091

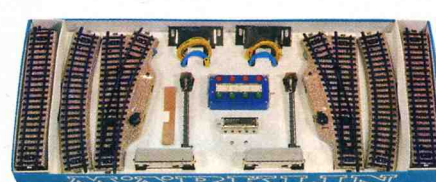

5092

For enlarging the sets 3200 and 3203 we recommend the supplementary track sets 5090, 5091 and 5092 on page 50 and for the set 3183, the supplementary track sets 2090 and 2091 on page 53.

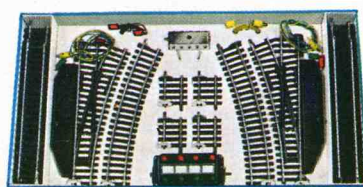

2090

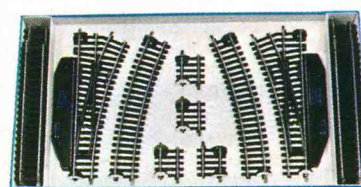

2091

Accurate descriptions of these sets are given on pages 50 and 53

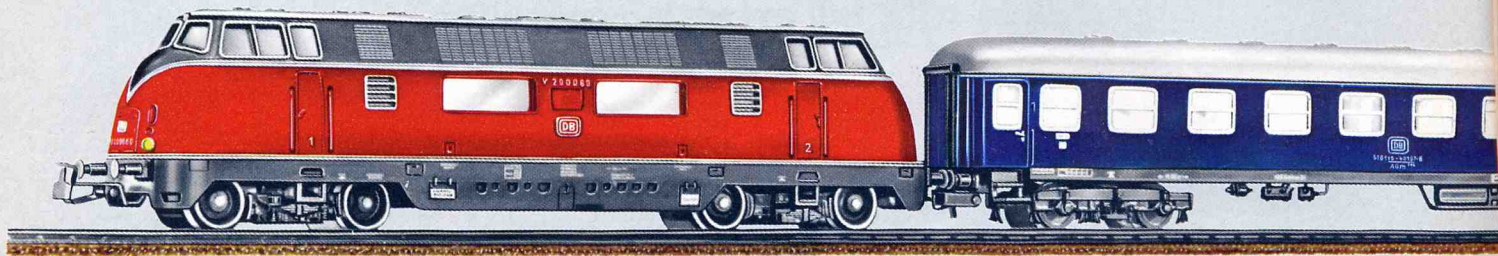

**Train sets
without transformer
with oval track
with full extension capability**

3122 M **NEW**

**Connect only to an alternating
current supply**

Express train (without transformer)

With diesel locomotive 3021,
2 passenger coaches fitted with
interior equipment, 1 baggage car
with corridor, 11 curved track
sections 5100, 1 feeder track section
5103 and 6 straight track sections
5106 · Train about 38" long

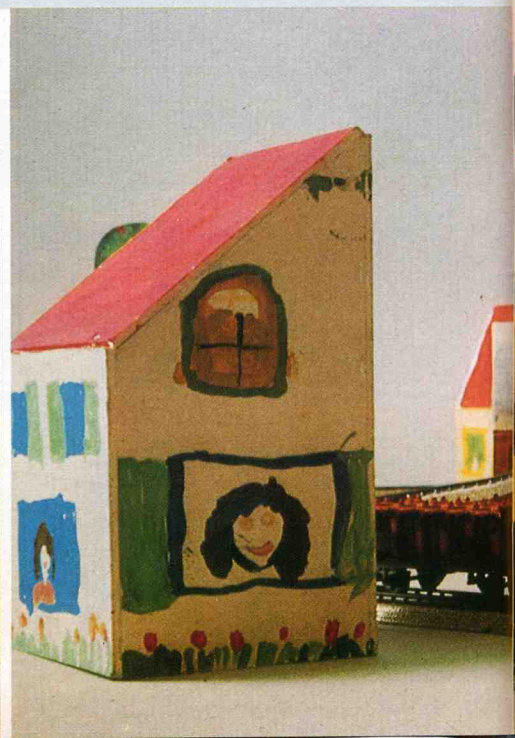
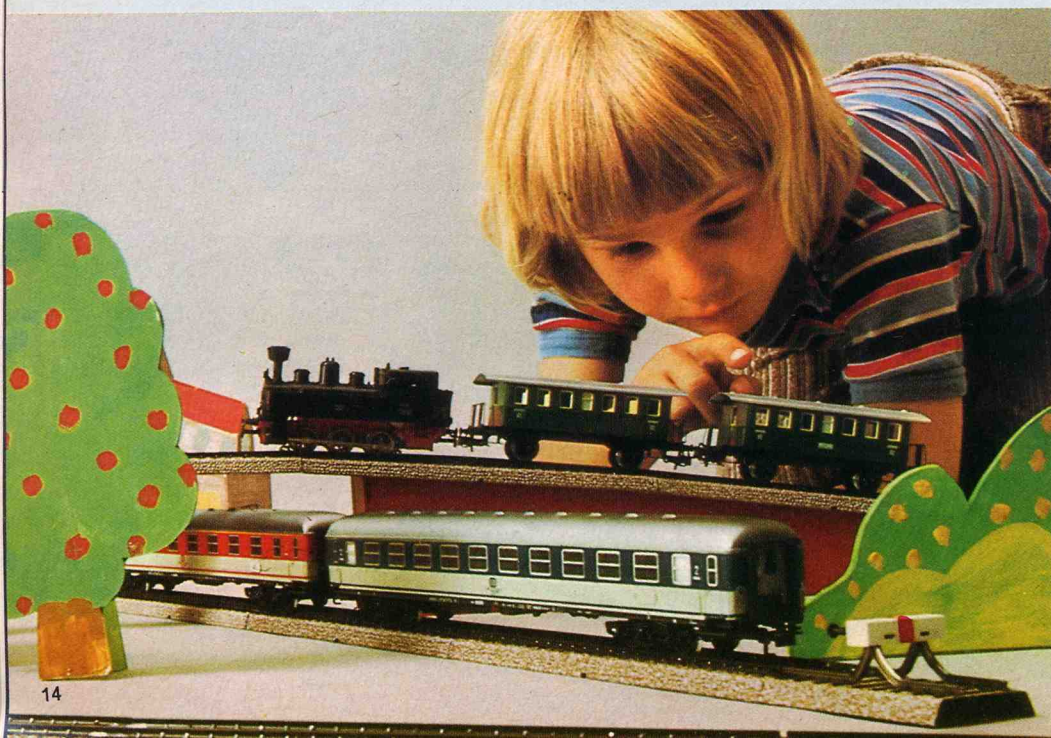
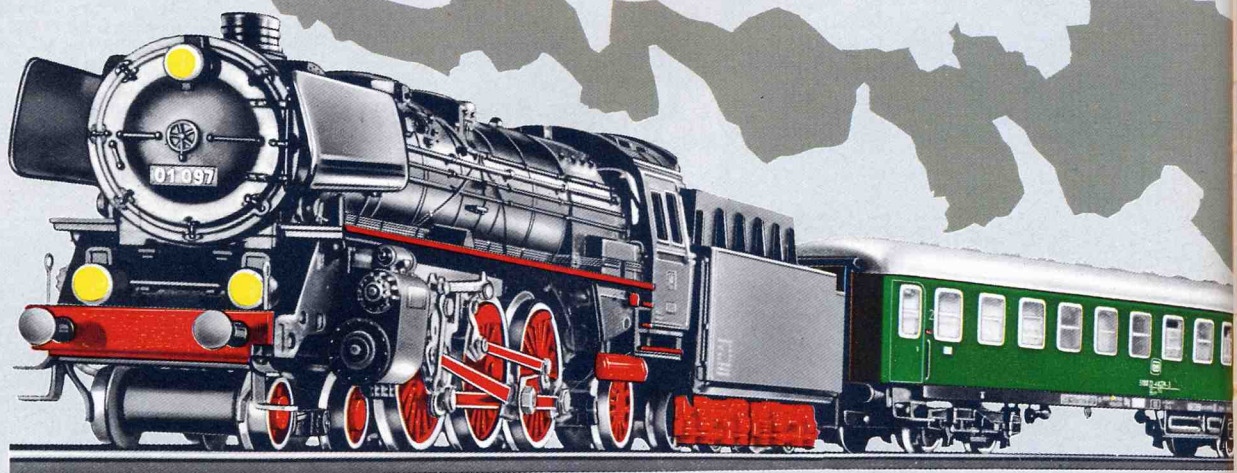

3122



For enlarging the set 3122 we recommend the supplementary track sets 5090, 5091 and 5092 on page 50.

3188 K

Express train with turnouts (without transformer)
With express locomotive 3048 with smoke unit, 4 passenger coaches without interior equipment, 14 straight track sections 2100, 4 straight track sections 2107, 10 curved track

sections 2131, 2 curved track sections 2132, 2 curved track sections 2134, 1 pair of remote control turnouts 2161, 1 feeder track section 2190, 1 control panel 7072 and 6 cables · Train 50" long

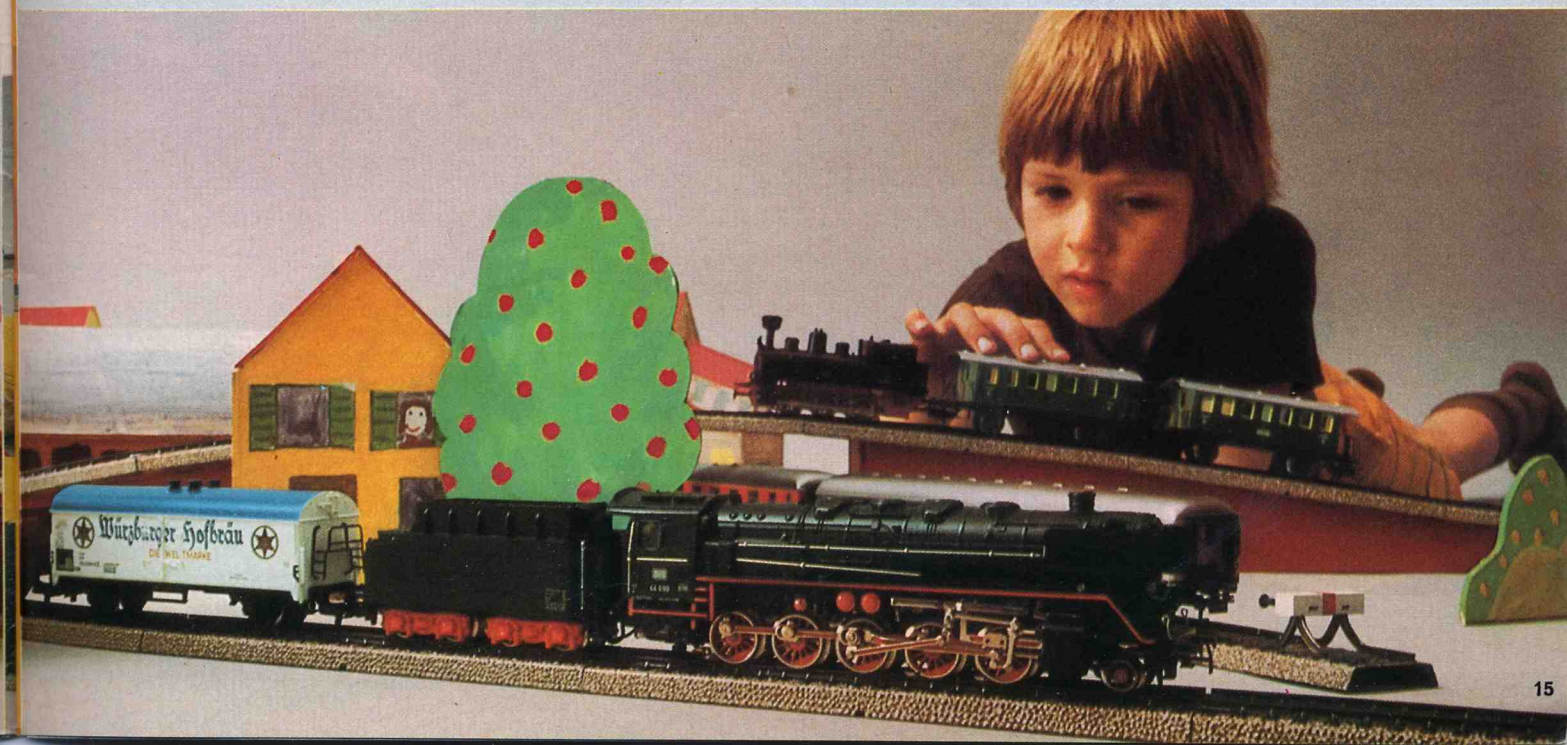

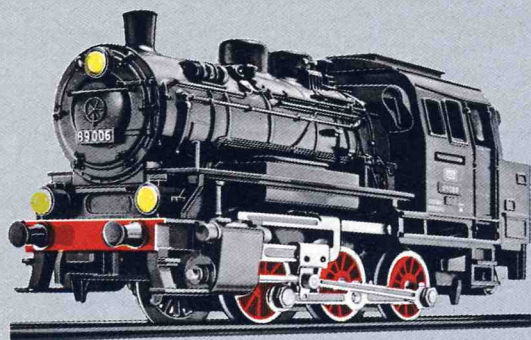

3000 Tank locomotive

Because of the many uses to which they can be put for passenger and freight train service and especially for switching work in switching yards, their attractive form and the ease with which they can be put on the track, many people favor these tank locomotives. Their ability to stay on curves at high speed and to pull heavy loads, and their harmonious shape are special advantages of these models.

3000 Tank locomotive · A model of the 0-6-0 Class 89 engine · 3 driven axles · 2 rubber tires to increase pulling power · Reversing by remote control · Three working headlights · Dull black plastic body · Die cast zinc frame · Coupling hooks both ends · 4 3/8" long over buffers

= 7154 = 7185 = 60010



3087 **NEW** Tank locomotive

3087 Tank locomotive · A model of a 0-6-0 type engine as used on secondary lines · 1 driven axle · 2 rubber tires to increase pulling power · Reversing by remote control · Dull black plastic body · Water tanks and driver's cab green · Die cast zinc frame · Coupling hooks both ends · 4 1/4" long over buffers

= 7154 = 7185

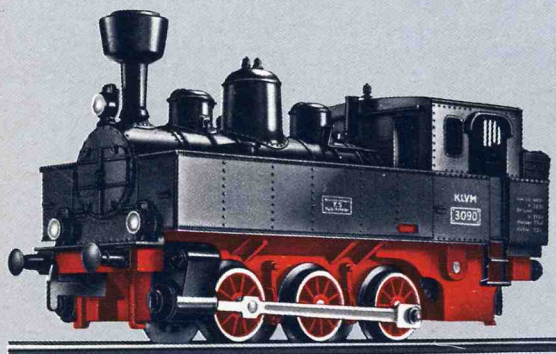

3090 **NEW** Tank locomotive

3090 Tank locomotive · A model of a 0-6-0 type engine as used on secondary lines · 1 driven axle · 2 rubber tires to increase pulling power · Reversing by remote control · Dull black plastic body · Die cast zinc frame · Coupling hooks both ends · 4 1/4" long over buffers

= 7154 = 7185

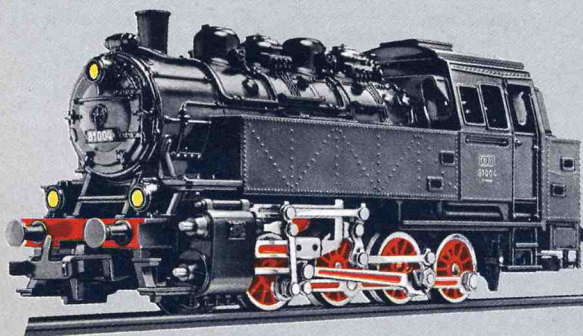

3031 Tank locomotive with MÄRKLIN TELEX-Coupling

3031 Tank locomotive · A model of the 0-8-0 Class 81 engine on the German Federal Railways · 4 driven axles · 2 rubber tires to increase pulling power · Simulated Heusinger valve gear · Reversing by remote control · Three working headlights · Dull black metal body · Die cast zinc frame · **MÄRKLIN TELEX-COUPPLINGS** both ends · About 5" long over buffers

= 7154 = 7185 = 60010

The **MÄRKLIN TELEX-COUPLING** enables the train to be uncoupled from the engine and also coupled up to it again at any desired point on the system, by remote control from the transformer, without any additional accessories being necessary.

The following locomotives are equipped with **MÄRKLIN TELEX-COUPPLINGS**: 3031, 3047, 3065 and 3096.

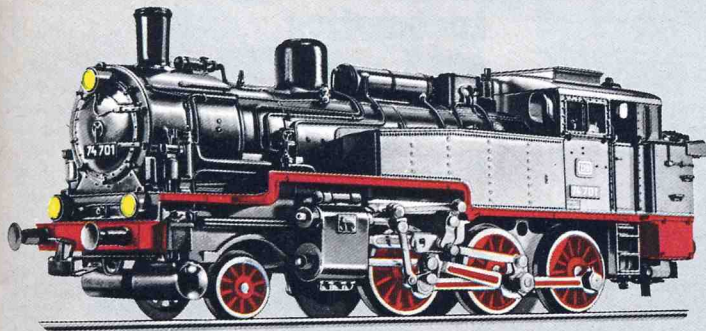

3095 "BR 74" A very desirable MÄRKLIN model

The first superheated steam tank locomotives were put into service by the Berlin State Railways Directorate in 1902. They proved so successful that hundreds of engines of this type were used for suburban passenger services right up to the time when the Berlin Circle, Metropolitan and suburban lines were electrified in the nineteen-twenties. Over the years, nearly 1000 of these very reliable engines were built. When they were no longer required in Berlin they were allotted to numerous centers for use on short distance passenger services and for switching work. Their length was 38 ft. 8 in. to 39 ft. 8 in. Weighing approximately 70 tons in working order, they could reach a speed of 50 miles an hour running either forward or tender first. Our model is copied from one of these engines which was in service at Düren for a time.

3095 Tank locomotive · A model of the German Federal Railways, 2-6-0 Class 74 engine · 3 driven axles · 2 rubber tires to increase pulling power · Simulated Heusinger valve gear · Reversing by remote control · Three working headlights · Dull black plastic body · Die cast zinc frame · Coupling hook in front with advance uncoupler; automatic coupling at rear with advance uncoupler (RELEX) · About 5 1/4" long over buffers

= 7153 = 7185 = 60010

HAMO 8396

The same model as 3096, but for two-rail D.C. operation (see page 25) and without TELEX-coupling

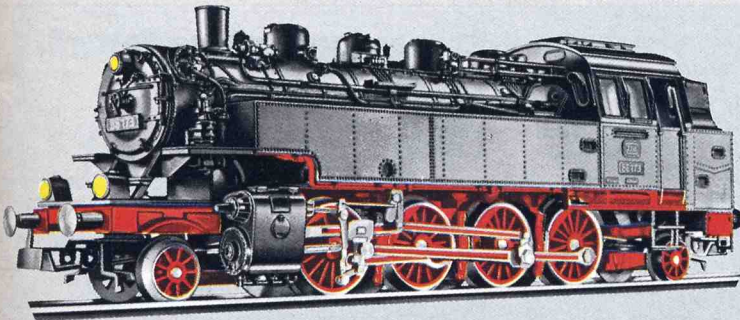

3096 "BR 86" Standard Locomotive used on the German Federal Railways with MÄRKLIN TELEX-Coupling

The standard Class 86 locomotive was developed for freight and passenger service on busy secondary lines. The number of engines of this type used by the former German State Railways reached the respectable total of 774. After the war the German Federal Railways took over 385 of them, but only a few are still in service. Some of them were equipped with Krauss-Helmholz frames which increased their speed from about 45 up to 50 miles an hour. The length of these locomotives is 46 ft. 6 in. With a weight of 88.5 tons in working order, the maximum axle load is 15.6 tons.

3096 Tank locomotive · A model of the Class 86 2-8-2 locomotive of the German Federal Railways · 4 driven axles · 2 rubber tires for increased pulling power · Simulation of the Heusinger valve gear · Reversing by remote control · Three working headlights on the front and rear · Fully detailed dull black plastic body with many extras mounted · Die cast zinc frame · **MÄRKLIN TELEX-COUPLING** on each end · 6 1/4" long over buffers

= 7153 = 7164 = 60015



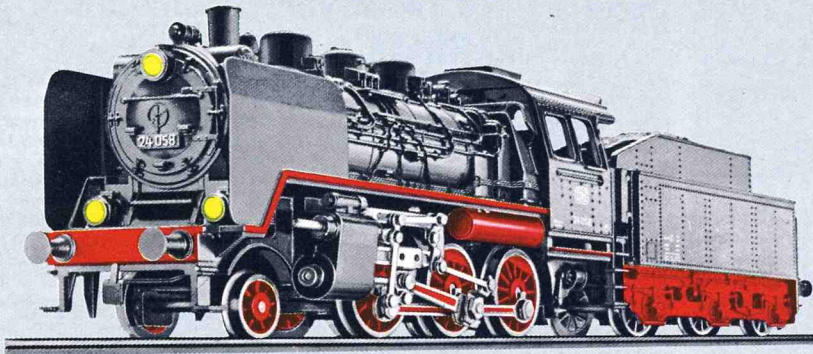

3003 Passenger locomotive with tender · A model of the 2-6-0 Class 24 engine of the German Federal Railways · 3 driven axles · 2 rubber tires to increase pulling power · Simulated Heusinger valve gear · Reversing by remote control · Three working headlights · Dull black plastic body · Die cast zinc frame · Coupling hook in front and automatic coupling

with advance uncoupler (RELEX) on the tender · 8" long over buffers

 = 7153  = 7185  = 60010

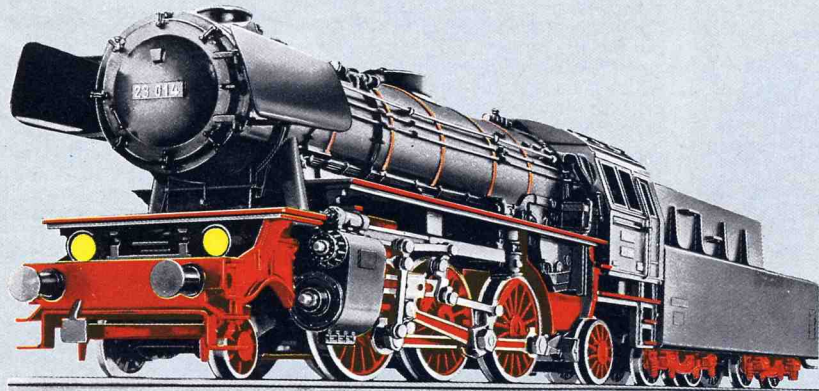

Mixed Traffic Steam Locomotive 3003

The standard Class 24 locomotive was used on the German Federal Railways for passenger and freight services, its maximum speed being 56 miles an hour.



3005 Locomotive with tender · A model of the ten-wheeled 2-6-2 Class 23 locomotive of the German Federal Railways · 3 driven axles · 2 rubber tires for extra pulling power · Simulated Heusinger valve gear · Reversing by remote control · 2 electric headlights · Dull black metal body · Die cast zinc frame · Coupling hook in front with automatic coupling with advance

uncoupler (RELEX) on the tender · 9 1/2" long over buffers

 = 7152  = 7173  = 60000

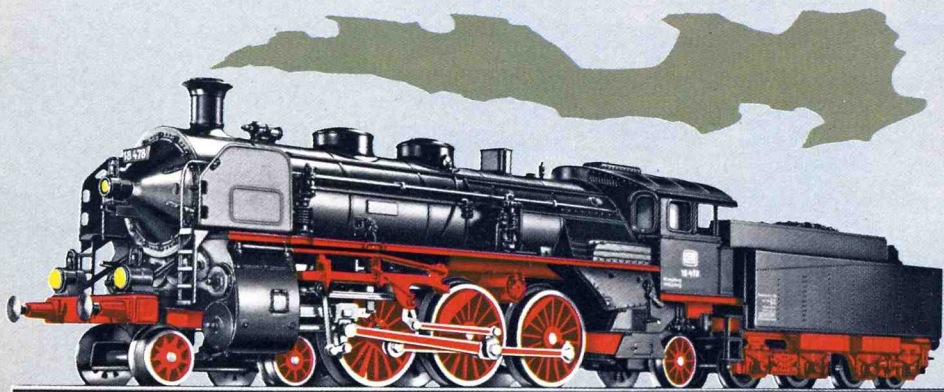

Steam locomotive for all types of service 3005

The German Federal Railways Class 23 locomotives are used for medium and heavy passenger service and for fast freight service. The locomotives and tenders are of welded construction, a design which enables them to be operated at speeds up to 70 mph forward and 55 mph when running tender first. Because of the high speed permitted when running backwards, they are used to a great extent in local service on heavy freight trains instead of tank locomotives.



3091 Express locomotive with tender · A model of the 4-6-0 Class 18 German Federal Railways locomotive (Bavarian S 3/6, series i) · 3 driven axles · 2 rubber tires for increased pulling power · Simulated Heusinger valve gear · Reversing by remote control · **Device to produce very realistic smoke**, consisting of a smoke unit built in to the locomotive and an ampule containing oil to produce the smoke (refill ampule 0241, see page 61) with a syringe

for filling up with oil · Three working headlights · Dull black metal body · Fully detailed valves and fittings · Die cast zinc frame · Automatic coupling on the tender with advance uncoupler (RELEX) · About 10" long over buffers

 = 7152  = 7185  = 60015

"BR 18" Express locomotives with smoke unit 3091 **NEW**

Connoisseurs regard the Bavarian S 3/6 class locomotives, with their powerful cylinder group, clearly arranged underframe, fairings and typical flared smokestack, as the best looking of all steam locomotives. The S 3/6's, whose designation was later changed to Class 18^a by the German Federal Railways, were often used to pull international expresses, including the famous "Rheingold", not only because of their appearance but because of their excellent performance. They reached a maximum speed of 75 mph with a weight in working order of 92.3 tons. They were just over 69 feet long over the buffers. The last engine of this class, No. 18478, was taken out of service in July 1960.

HAMO

8391

NEW

The same model as 3091 but for two-rail D.C. operation (see page 25)

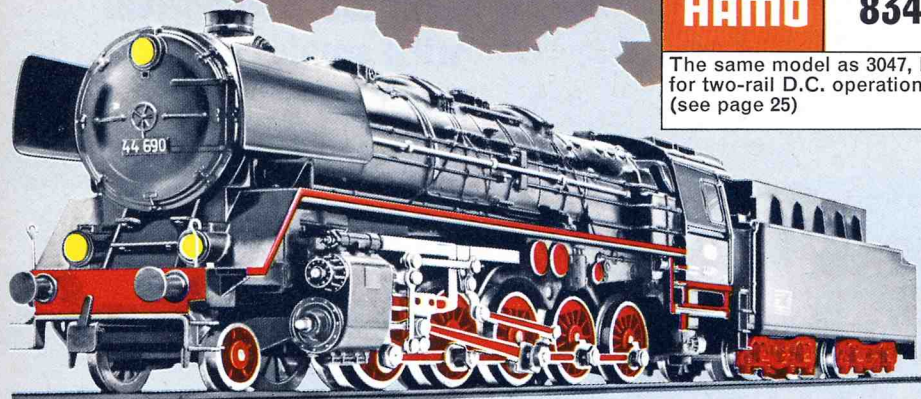

HAMO 8347

The same model as 3047, but for two-rail D.C. operation (see page 25)

The heavy freight locomotive with smoke unit and MÄRKLIN TELEX-Coupling 3047

This is one of the most powerful steam locomotives in freight service on the German Federal Railways. The prototype Class 44 develops nearly 2000 HP. This magnificent locomotive is seen on long distance runs in areas which have not yet been electrified. Because of the imposing look of this magnificent locomotive we have taken meticulous care in modelling it.

The **MÄRKLIN TELEX-COUPLING** fitted to the tender enables the train to be uncoupled at any point on the system, and also coupled up again, by remote control from the transformer, without any additional equipment being required.

= 7153 = 7175 = 60010

3047 Heavy freight locomotive with tender · A model of the German Federal Railways Class 44 2-10-0 locomotive · The locomotive and tender are permanently coupled together · Excellent running characteristics and easy running on curves are obtained, in spite of the 5 driven axles, by dividing the frame into two different groups of driving wheels · 4 rubber tires to increase pulling power · Simulated Heusinger valve gear · Reversing by remote control ·

Device for producing very realistic smoke, consisting of the smoke unit fitted in the engine, substitute steam pipe, cleaning wire, tweezers and an ampule of oil for producing the steam (refill ampule 0241, see page 61) · Three working headlights · Dull black metal body · Die cast zinc frame · Coupling hook in front, **MÄRKLIN TELEX-COUPLING** on the tender · 11" long over buffers

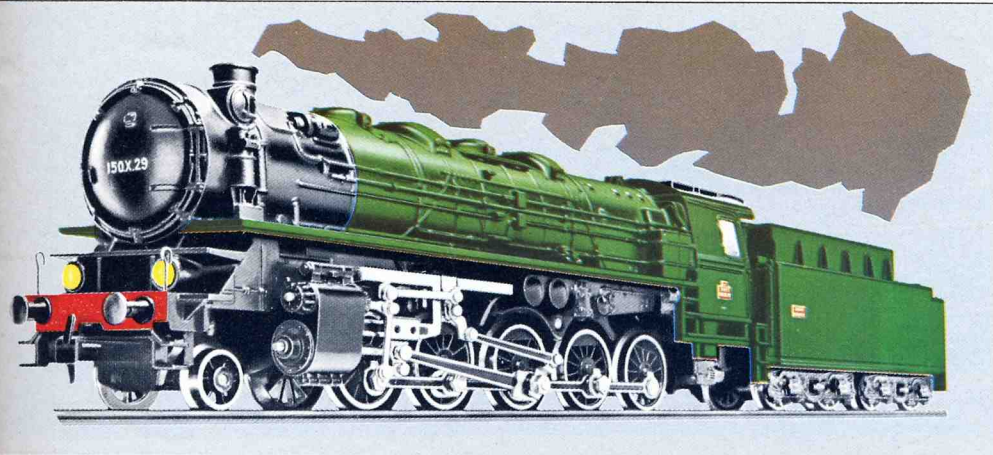

French Railways' heavy freight locomotive with smoke unit 3046

HAMO 8346

The same model as 3046, but for two-rail D.C. operation (see page 25)

ling with advance uncoupler (RELEX) on the tender · 11" long over buffers

= 7153 = 7175 = 60010

3046 Heavy freight locomotive · A model of the Class 150 X 2-10-0 locomotive of the French State Railways (Société Nationale des Chemins de Fer Français or SNCF) · Excellent running characteristics and easy running on curves are obtained, in spite of the 5 driven axles, by dividing the frame into two different groups of driving wheels linked together · 4 rubber tires to increase pulling power · Simulated Heusinger

valve gear · Reversing by remote control · **Device for producing very realistic smoke**, consisting of a smoke unit fitted in the engine, substitute steam pipe, cleaning wire, tweezers and an ampule of oil for producing smoke (refill ampule 0241, see page 61) · 2 working headlights · Dull green metal body · Die cast zinc frame · Coupling hook in front, automatic coup-

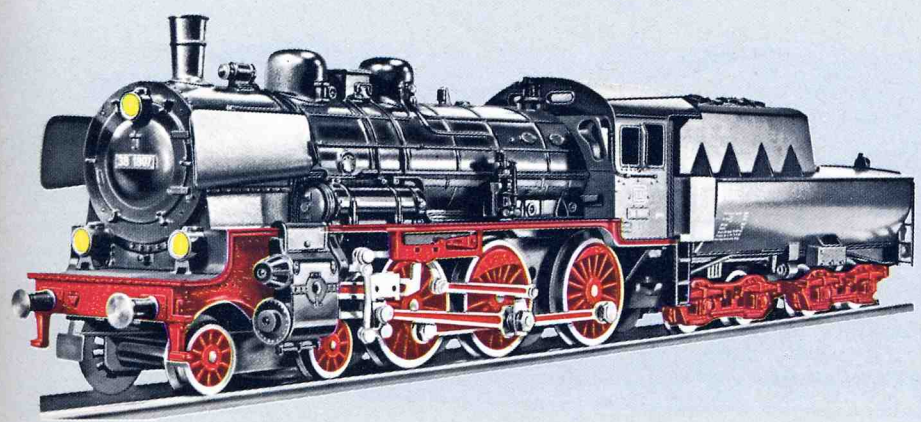

The handsome "P 8" as a MÄRKLIN model 3098

The P 8 was built in Berlin by Schwarzkopff as far back as 1906 and it was used by the Prussian State Railways for local and express services. Although it was approved for a maximum speed of only 63 mph, because of its reliability it remained one of the preferred types of locomotive for very many years in some of the regions. Altogether 3800 of these locomotives were built by a number of different firms. A few of them are still running on the Federal Railways' tracks.

3098 Locomotive with tender · A model of the German Federal Railways Class 38 4-6-0 locomotive · 3 driven axles · 2 rubber tires for increasing pulling power · Simulation of Heusinger valve gear · Reversing by remote control · Three working headlights · Dull black metal body with detailed imitation of the boiler and driver's cab valves and fittings · Die cast zinc frame · Coupling hook in front, automatic

coupling with advance uncoupler (RELEX) on the tender · 9 3/8" long over buffers

= 7152 = 7185 = 60015

HAMO 8398

The same model as 3098, but for two-rail D.C. operation (see page 25)



3048 Express locomotive with tender · A model of the 4-6-2 Class 01 locomotive of the German Federal Railways · 3 driven axles · 2 rubber tires to increase pulling power · Simulated Heusinger valve gear · Reversing by remote control · **Device for producing very realistic smoke,**

consisting of the smoke unit fitted in the engine, substitute steam pipe, cleaning wire, tweezers and an ampule of oil for producing smoke (refill ampules 0241, see page 61) · Three working headlights · Dull black body · Die cast zinc frame · Automatic coupling on the tender with

advance uncoupler (RELEX) · 11" long over buffers

= 7152 = 7185 = 60010

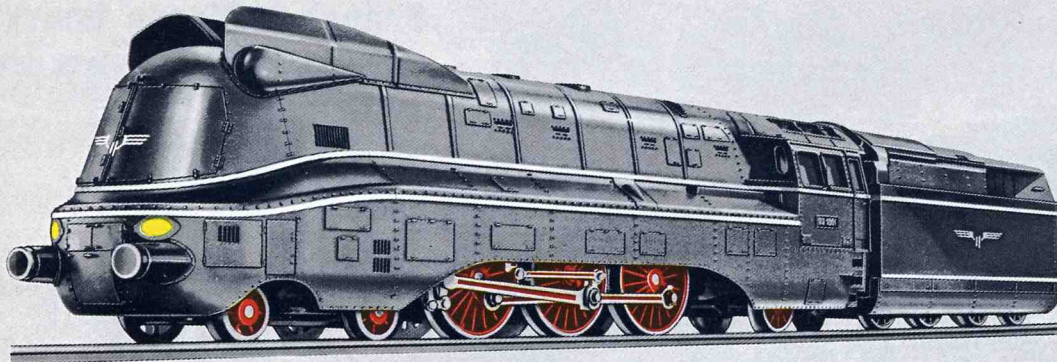

3094 Streamlined express locomotive with tender · A model of the former German State Railways 4-6-2 Class 03¹⁰ locomotive · 3 driven axles · 2 rubber tires to increase pulling power · Simulated Heusinger valve gear · Reversing by remote control · 2 working headlights · Dull black streamlined metal body with silver stripes · Fully detailed cab and boiler valves and fittings · Die cast zinc frame · Automatic coupling on the tender with advance uncoupler (RELEX) · 10 3/4" long over buffers

After streamlined fairings had proved themselves on other locomotives by reducing the wind resistance at high speeds, the Class 03¹⁰ locomotives with three-cylinder engines were put into service with streamlined fairings in 1937. For easier maintenance however the driving wheels were left uncovered. This class was developed as a lighter version of the Class 01 with an original axle load of 17 tons and a top speed of 85 mph.

Streamlined Express Locomotive "03¹⁰"
3094

= 7152 = 7185 = 60015

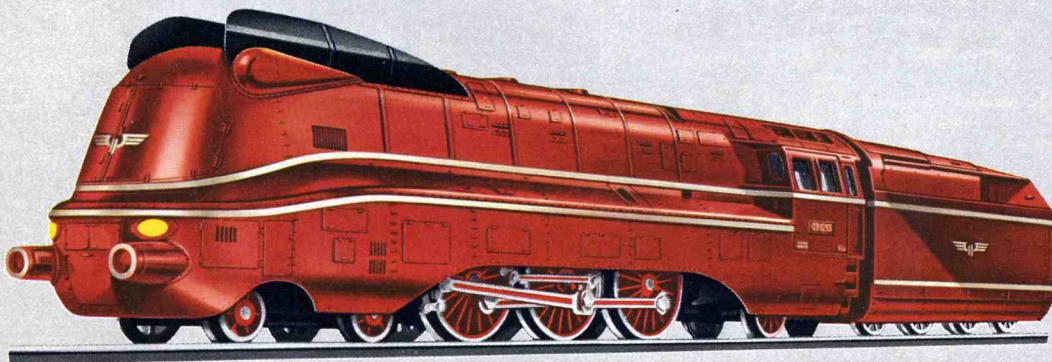

3089 Streamlined express locomotive with tender · The same model as 3094, but with dark red streamlined metal body with silver stripes · Black wind deflectors

= 7152 = 7185 = 60015

HAMO 8389

NEW

The same model as 3089, but for two-rail D.C. operation (see page 25)

"03¹⁰" - Dark Red Finish - 3089

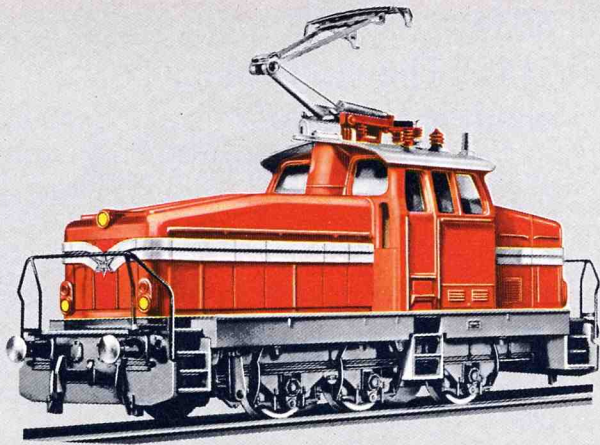

3044 Electric locomotive · Model of the Mehr-system industrial locomotive of Type EA 800 · Six-wheeled with all axles powered · Two rubber tires to increase pulling power · Reversing by remote control · Switch lever for selecting operation from the overhead contact wire or the track contacts · Three working headlights · Red

plastic body · Single-bar pantograph mounted on roof · Die cast zinc frame · Fully detailed journal boxes · Coupling hooks both ends · 4 1/2" long over buffers

= 7154 = 7166 = 60015

Electric switching locomotive "EA 800"

3044

Locomotives of this type were designed for heavy track and switching service on industrial lines and for transferring cars to mainline railroads. They can draw power either from overhead lines or from internal batteries. Maximum speed is approximately 35 mph. The locomotive with single-axle drive develops 39000 lbs tractive effort. It weighs 60 tons and measures 32 feet in length.



3022 Electric freight locomotive · A model of the twelve-wheeled 0-6-6-0 (Co-Co) Class 194 locomotive of the German Federal Railways · 3 driven axles · 4 rubber tires to increase pulling power · Reversing by remote control · Three working headlights · Switch lever for selecting operation from the overhead contact wire or the

track contacts · Two spring-loaded pantographs on roof · Green, three-section metal body · Silvered roof · Inset windows with plastic frames · Automatic coupling with advance uncoupler (RELEX) at both ends · 8 1/4" long over buffers

= 7153 = 7164 = 60015

"194" Heavy Electric Freight Locomotive

3022

The Class 194 locomotive is the workhorse of the railways. The starting power of the six motors applies 6350 HP to the wheels. With a service weight of 120 tons they have a maximum starting tractive power of 40 tons. They reach a maximum speed of only about 56 mph it is true, but on the other hand, even with the heaviest freight train, no gradient is too much for them. 124 of these 70-foot long giants are in operation on the German Federal Railways.

HAMO

8322

The same model as 3022 but for two-rail D.C. operation (see page 25)



3054 Electric express locomotive · A model of the German Federal Railways Class 103 locomotive with two six-wheeled trucks · 3 driven axles · 4 rubber tires to increase pulling power · Reversing by remote control · Three working headlights · Switch lever for selecting operation from the overhead contact wire or the track contacts · Die cast zinc locomotive frame · Fixed

buffer beams · Special low centre of gravity · Plastic body in the TEE colors, beige and red · Aluminum color roof · Inset windows with plastic frames · 2 spring-loaded pantographs on roof · Coupling hooks both ends · 8 1/2" long over buffers

= 7153 = 7164 = 60015

Express Locomotive "103"

3054

This is at present the most elegant, most powerful and fastest electric express locomotive of the German Federal Railways. 62 feet in length, its six axles are driven by six motors developing nearly 9000 HP. Its service weight is 112 tons and the mighty tractive force of 32 tons takes account of requirements in the future. On suitable tracks, expresses pulled by the 103 electric locomotive travel at maximum speeds of 125 mph. All the splendid features of the original are captured in the small MÄRKLIN model.

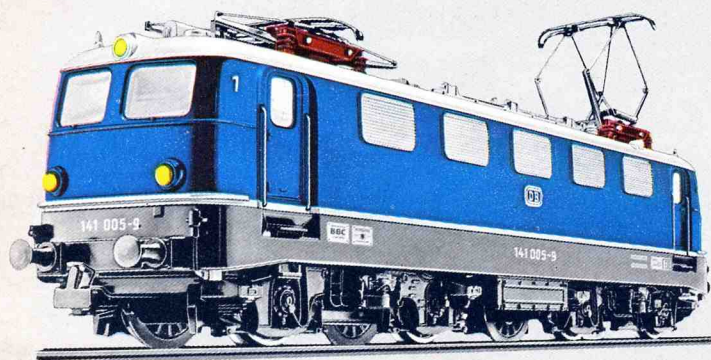

3034 "141" The multi-purpose electric locomotive

The Class 141 has an in-service weight of 66.4 tons and a length of 50 feet. Its four traction motors develop about 3100 HP giving a maximum speed of 75 mph. It is used for both fast passenger and freight service. There are locomotives of this class finished in blue or green in service at the German Federal Railways.

3034 Electric locomotive · A model of the German Federal Railways' 0-4-4-0 Class 141 locomotive · 2 driven axles · 4 rubber tires to increase pulling power · Reversing by remote control · Three working headlights · Switch lever for selecting operation from the overhead contact wire or the track contacts · 2 spring-loaded pantographs on the roof · Blue metal body · Fixed buffer beams · Silver roof · Coupling hooks with advance uncoupler at both ends · 7" long over buffers

= 7153 = 7164 = 60015

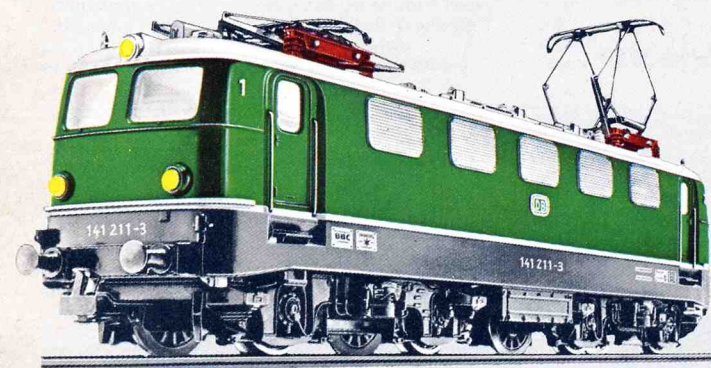

3037

3037 Electric locomotive · A model of the German Federal Railways' Class 141 · Similar to 3034, except the body is green

= 7153 = 7164 = 60015

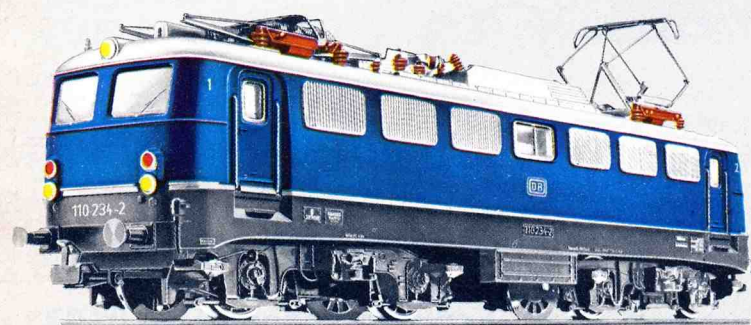

3039 Electric express locomotive "110"

The electric locomotives of Classes 110 and 140 were purchased by the German Federal Railways in 1956. The 110 is used as an express locomotive with a maximum speed of 90 mph, while the 140 is used for freight service with a maximum speed of 70 mph. Both of them have four traction motors developing about 5000 HP in all, but the power is transmitted to the driving wheels through different gears.

The locomotives weigh 85 tons and are nearly 50 feet long over the buffers.

3039 Electric express locomotive · A model of the 8-wheeled, two-truck Class 110 locomotive of the German Federal Railways · 2 driven axles · 4 rubber tires to increase pulling power · Reversing by remote control · Three working headlights · Switch lever for selecting operation from the overhead contact wire or the track contacts · Blue metal body · Fixed buffer beams · Scale reproduction of all roof details · 2 spring-loaded pantographs on roof · Silver roof · Inset windows with plastic frames · Coupling hooks with advance uncouplers both ends · 7 1/8" long over buffers

= 7153 = 7164 = 60015

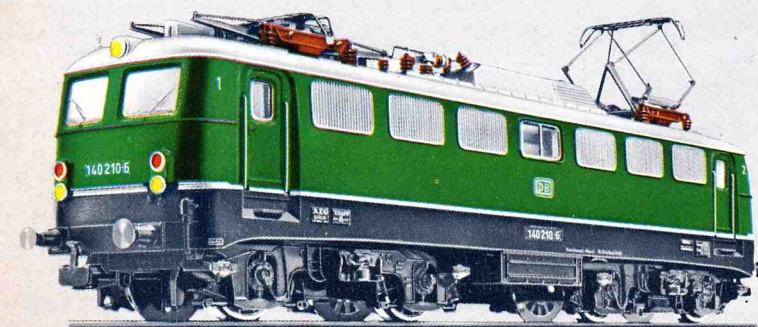

3040 "140" German Freight Locomotive

3040 Electric freight locomotive · A model of the 8-wheeled, two-truck Class 140 locomotive of the German Federal Railways · 2 driven axles · 4 rubber tires to increase pulling power · Reversing by remote control · Three working headlights · Switch lever for selecting operation from the overhead contact wire or track contacts · Green metal body · Fixed buffer beams · Scale reproduction of roof details · 2 spring-loaded pantographs on roof · Silver roof · Inset windows with plastic frames · Coupling hooks with advance uncouplers both ends · 7 1/8" long over buffers



= 7153 = 7164 = 60015



3035

Italian electric locomotive

3035 Electric locomotive · A model of the Italian State Railways' 0-4-4-0 Class E 424 locomotive · 2 driven axles · 4 rubber tires to increase pulling power · Reversing by remote control · Two working headlights front and rear · Switch lever for selecting operation from overhead contact wire or track contacts · 2 spring-loaded pantographs on roof · Brown metal body · Fixed buffer beams · Coupling hooks with advance uncouplers both ends · 6 7/8" long over buffers

 = 7153
  = 7164
  = 60015





3036

Austrian Electric Locomotive

The Austrian Class 1141 electric locomotive is in service mainly in regions where the conditions are favorable as regards gradients and curves. It weighs 80 tons, develops 3400 HP and has a top speed of 69 mph. It is used for mixed traffic.

3036 Electric locomotive · A model of the Austrian State Railways' 0-4-4-0 Class 1141 locomotive · 2 driven axles · 4 rubber tires to increase pulling power · Reversing by remote control · Two working headlights front and rear · Switch lever for selecting operation from overhead contact wire or track contacts · 2 spring-loaded pantographs on roof · Green metal body · Fixed buffer beams · Coupling hooks with advance uncouplers both ends · 6 7/8" long over buffers

 = 7153
  = 7164
  = 60015

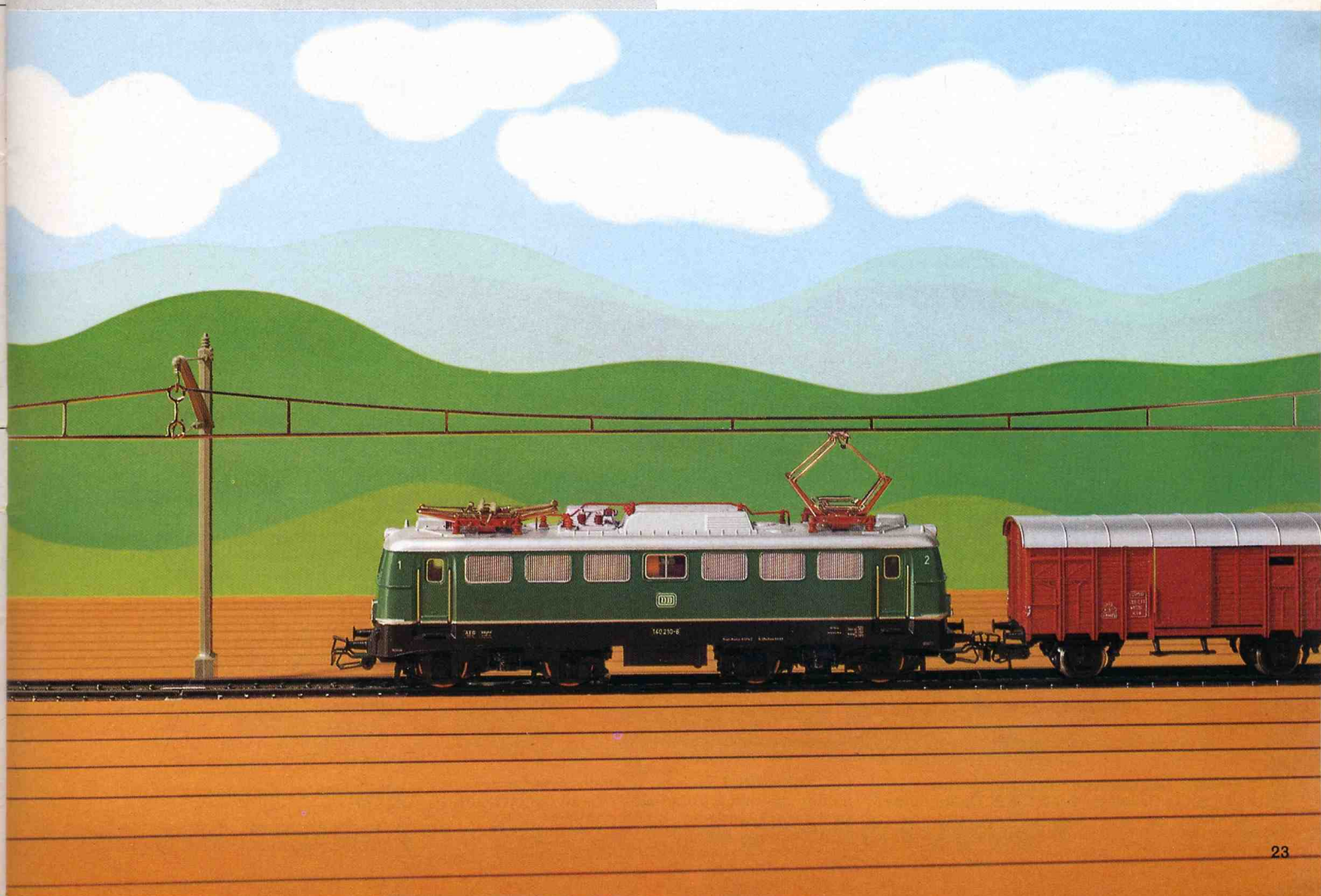
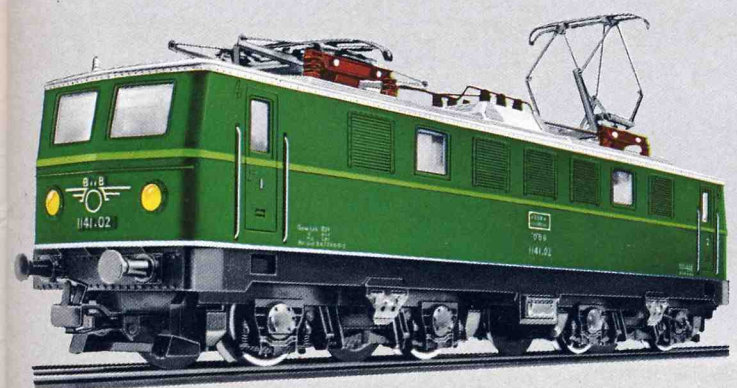

Electric Locomotives

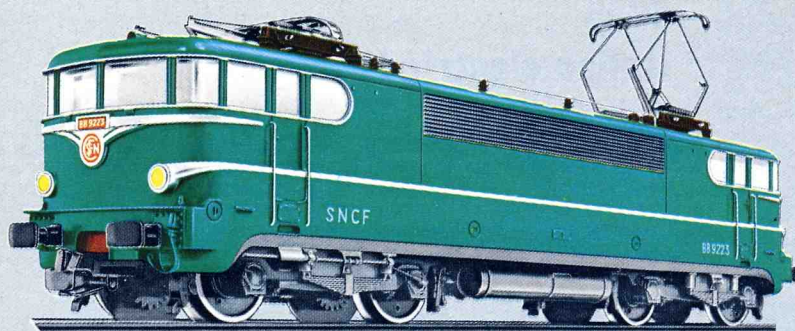

3038 Electric locomotive · A model of the 0-4-4-0 Class BB 9200 locomotive of the French Railways (Société Nationale des Chemins de Fer Français or SNCF) · 2 driven axles · 4 rubber tires to increase pulling power · Reversing by remote

control · 2 working headlights · Switch lever for selecting operation from overhead contact wire or track contacts · 2 spring-loaded pantographs on roof · Turquoise metal body · Fixed buffer beams · Coupling hooks with advance uncouplers

French high-power electric locomotive 3038

The French prototype of our model 3038 runs on certain stretches of the French railways at a maximum speed of 100 mph. The locomotives of Class BB 9200 have four traction motors developing together 5500 HP. They weigh 80 tons.

both ends · 7" long over buffers

⊖ = 7153 ⊞ = 7164 ⚡ = 60015

Electric locomotives of the Netherlands Railways 3055

NEW

3051

3051 Electric locomotive · A model of the Netherlands Railways' Class 1200 · Similar to 3055, but with blue metal body

⊖ = 7154 ⊞ = 7164 ⚡ = 60015

⊖ = 7154 ⊞ = 7164 ⚡ = 60015

Interesting Swedish multipurpose locomotive 3043

In these locomotives of very modern design, A.C. power at 16 $\frac{2}{3}$ c/s, taken from the overhead wires, is converted by thyristors to D.C., which drives the four traction motors delivering a total of almost 5000 HP. The locomotive weighs 76 tons and reaches 84 mph. It is almost 52 feet long over the buffers.

beams · Coupling hooks both ends · 6 $\frac{7}{8}$ " long over buffers

⊖ = 7153 ⊞ = 7164 ⚡ = 60015

Swedish electric locomotive 3030

The Class Da is operated by the Swedish State Railways (Statens Järnvägar) as the standard electric locomotive for passenger and freight service. Since these locomotives have only one motor and the axle load at 15 or 17 tons is low, they are fitted with connecting rod drive. This prevents the wheels of individual driven axles "running away" when starting from rest.

coupling with advance uncoupler (RELEX) both ends · 5 $\frac{1}{8}$ " long over buffers

⊖ = 7153 ⊞ = 7173 ⚡ = 60015



3055 Electric locomotive · A model of the Netherlands Railways' 0-6-6-0 Class 1200 locomotive · 3 driven axles · 4 rubber tires to increase pulling power · Reversing by remote control · Three working headlights · Switch lever for selecting

operation from overhead contact wire or track contacts · Grey-yellow metal body · Fixed buffer beams · 2 spring-loaded pantographs on roof · Inset windows with plastic frames · Coupling hooks both ends · 7 $\frac{1}{4}$ " long over buffers



3043 Electric mixed traffic locomotive · A model of the Swedish State Railways' eight-wheeled Class Rc locomotive · 2 driven axles · 4 rubber tires to increase pulling power · Reversing by remote control · 4 working headlights front and

rear · Switch lever for selecting operation from the overhead contact wire or the track contacts · Orange colored plastic body · Inset windows with plastic frames · 2 spring-loaded pantographs on roof · Die cast zinc frame with fixed buffer



3030 Electric locomotive · A model of the Swedish State Railways' 2-8-2 Class Da locomotive · 3 driven axles · Jackshaft driven through gears · 2 rubber tires to increase pulling power · Reversing by remote control · Three working

headlights front and rear · Switch lever for selecting operation from the overhead contact wire or the track contacts · 2 spring-loaded pantographs on the roof · Brown metal body · Fixed buffer beams · Die cast zinc frame · Automatic



HAMO

HAMO locomotives for two-rail D.C. operation are equipped with permanent magnet motors and can be reversed by changing the polarity of the current. Electric locomotives have headlights on each end that change when you change the direction of the locomotive. These models can be run on all tracks conforming to NEM standards. A set of interchange couplings is supplied with each locomotive, allowing other makes of rolling stock to be coupled to it. HAMO locomotives are a product of MÄRKLIN

Accessories for MÄRKLIN HO Locomotives (see page 61)

- | | |
|----------------------|----------------------------|
| Rubber tires | Pantographs |
| Current pickup shoes | Bottles of lubricating oil |
| Light bulbs | Smoke fluid |
| Reverse unit springs | |



Swiss heavy freight electric locomotive "Crocodile"

3015

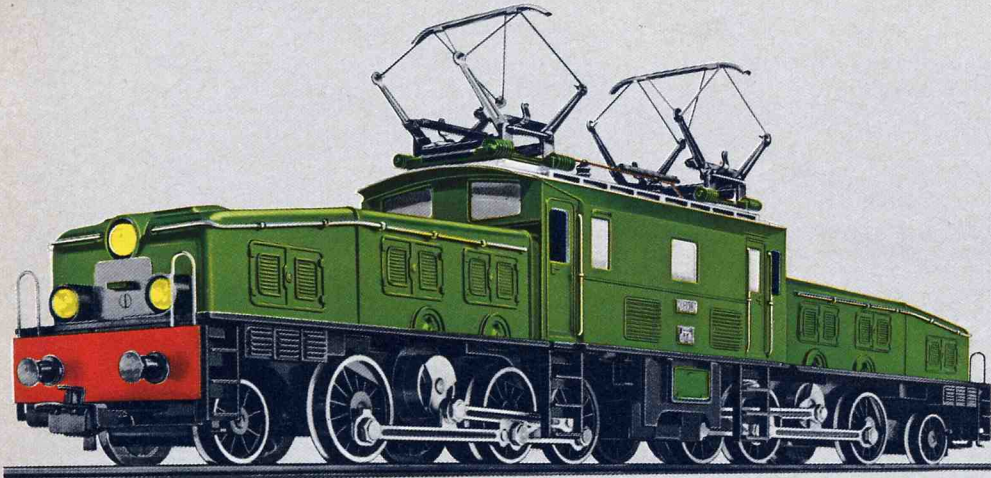

This giant Swiss electric locomotive Be 6/8 on eight axles, a real "King of the Mountains" is nicknamed "The Crocodile". It is undoubtedly the most impressive locomotive of the Swiss Railways. It is with particular pleasure that we have modelled this prototype with the greatest care on the H0 scale.



3015 Electric freight locomotive · A model of the Swiss Federal Railways' 2-6-6-2 Series Be 6/8 ("Crocodile") locomotive · 6 driven axles · 2 rubber tires to increase pulling power · Because of its articulated construction it can

negotiate standard curves with ease · Reversing by remote control · Three working headlights at each end with automatic change-over · Switch lever for selecting operation from the overhead wires or the track contacts · 2 spring-loaded

pantographs on the roof · Green metal body · Automatic coupling with advance uncoupler (RELEX) each end · 10 1/4" long over buffers

-  = 7153
-  = 7175
-  = 60000



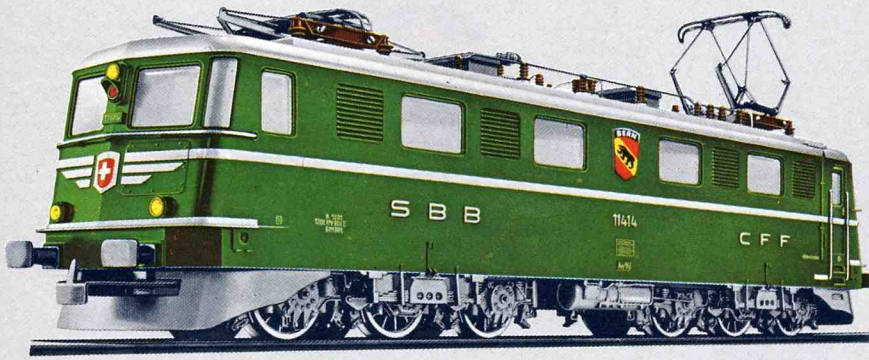



The Swiss Federal Railways' powerful multi-purpose locomotive 3050

The Swiss Federal Railways ordered the Ae 6/6 for international passenger and express freight service. The locomotive's weight of 120 tons and the 6000 HP developed by its six motors give it enormous starting and climbing power. The maximum speed is 80 mph. With all its giant power, it still has a particularly handsome appearance, which is reason enough for us to model it most accurately.

3050 Electric all-purpose locomotive · A model of the Swiss Federal Railways twelve-wheeled series Ae 6/6 locomotive · 3 driven axles · 4 rubber tires to increase pulling power · Reversing by remote control · Three working

headlights at each end · Switch lever for selecting operation from the overhead wires or the track contacts · 2 spring-loaded pantographs on the roof · Green metal body · Fixed buffer beams · Silver colored roof · Copied from the "Berne

Canton" locomotive · Coupling hooks at each end · 7 1/8" long · Crests of the other Swiss cantons are supplied with this locomotive

 = 7153  = 7164  = 60015







3078 Diesel hydraulic locomotive "DHG 500"

These "small" diesel locomotives with hydraulic transmission nevertheless measure about 40 feet long and have several hundred horsepower "under their hoods." The heavily loaded gears particularly, are especially robust, so that these locomotives can be used for long periods of time with an insignificant amount of servicing. These locomotives, which are typical of industrial locomotives (MÄRKLIN models 3078, 3080), have windows low down in the front side panels of the engineers cab which allow direct vision to the buffers for accurate switching.

3078 Diesel locomotive · A model of a 0-6-0 industrial locomotive known as the DHG 500 type · 3 driven axles · 2 rubber tires to increase the pulling power · Reversing by remote control · Three working headlights at each end · Blue plastic body with two silver decorative bands · Die cast zinc frame · Coupling hooks each end · 4 3/8" long over buffers

 = 7154  = 7166  = 60015



3080 Industrial Locomotive

3080 Diesel locomotive · A model of a 0-6-0 industrial locomotive · 3 driven axles · 2 rubber tires to increase pulling power · Reversing by remote control · Yellow plastic body with 2 dark decorative bands · Die cast zinc frame · Coupling hooks each end · 4 3/8" long over buffers

 = 7154  = 7166





3065 Diesel hydraulic switching locomotive "260" with TELEX-Coupling

3065 Diesel locomotive · A model of the German Federal Railways' 0-6-0 Class 260 locomotive · 3 driven axles · 2 rubber tires to increase pulling power · Reversing by remote control · Three working headlights at each end · Red plastic body · Inset windows with plastic frames · Die cast zinc frame · **MÄRKLIN TELEX-COUPLING** at each end · 4 1/4" long over buffers

= 7153 = 7185 = 60010

TELEX see page 16

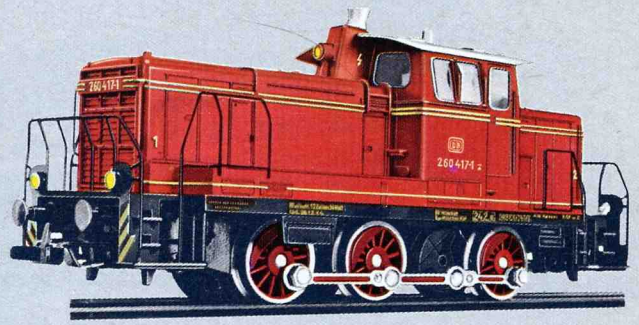

3064 with coupling hooks

3064 Diesel locomotive · A model of the German Federal Railways' Class 260 locomotive · Similar to 3065 but **without** MÄRKLIN TELEX coupling · Coupling hooks with advance uncoupler at each end

= 7153 = 7185 = 60010

3072 Diesel hydraulic locomotive "212"

The 212 is a multi-purpose diesel locomotive, 40 feet long and weighing 63.2 tons in service order. The new types develop 1350 HP which is transmitted hydraulically through universal drive shafts to all four axles. In order to use the tractive force of the powerful motor to meet the requirements both for passenger and freight service, a dual-ratio gear box is provided which can be operated from the driver's cab. In low gear the locomotive has maximum power but the maximum speed then is only 44 mph, while in high gear it reaches 65 mph.

3072 Diesel locomotive · A model of the German Federal Railways' two-truck (B B) Class 212 locomotive · 2 driven axles · 4 rubber tires to increase pulling power · Reversing by remote control · Three working headlights at each end · Die cast zinc frame · Red plastic body · Narrow front and rear ends to scale · Inset windows with plastic frames · Automatic coupling with advance uncoupler (RELEX) at each end · 5 1/2" long over buffers · The front and rear ends of model 3072 have been kept narrow as on the prototype, by a specially designed arrangement of the motor.

= 7154 = 7164 = 60010

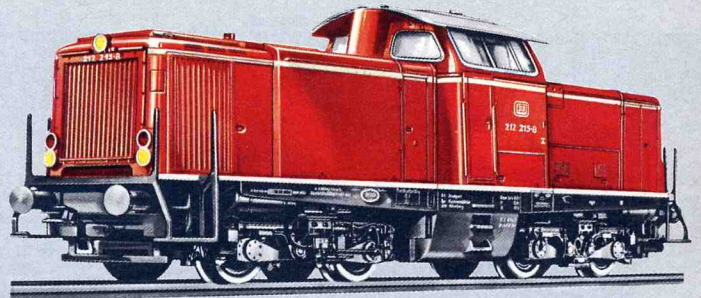

3075 Diesel locomotive "216"

The Class 216 diesel locomotive is used for medium mainline service. With full fuel tanks it weighs 79 tons and develops 1900 HP, reaching a maximum speed of 75 mph.

3075 Diesel locomotive · A model of the German Federal Railways' 0-4-4-0 Class 216 locomotive · 2 driven axles · 4 rubber tires to increase pulling power · Reversing by remote control · Three working headlights at each end · Red-grey plastic body · Grey roof · Inset windows with plastic frames with simulated windshield wipers · Die cast zinc frame · Fixed buffer beams · Automatic coupling with advance uncoupler (RELEX) at each end · 7 1/8" long over buffers

= 7154 = 7164 = 60015



HAMO	8375
The same model as 3075, but for two-rail D.C. operation (see page 25)	

3021 Diesel hydraulic express locomotive "220"

3021 Diesel locomotive · A model of the German Federal Railways' Class 220 locomotive · 2 driven axles · 4 rubber tires to increase pulling power · Reversing by remote control · Three working headlights each end · Red-grey metal body · Fixed buffer beams · Silver-grey roof · Coupling hook with advance uncoupler at each end · 8 1/4" long over buffers

= 7154 = 7183 = 60010





Belgian Railways multi-purpose diesel locomotive 3066

The Belgian multi-purpose diesel locomotive, type 204, has diesel-electric drive. Developing 1750 HP it is engaged in hauling light freight trains as well as local and express passenger trains and reaches a maximum speed of about 87 mph.

3066 Diesel locomotive · A model of the Belgian State Railways' (SNCRB) 0-6-6-0 (Co-Co) Type 204 locomotive · 3 driven axles · 4 rubber tires to increase pulling power · Reversing by remote control · Three working headlights at each end · Green metal body · Fixed buffer beams · Black roof · Inset windows with plastic

frames · Coupling hooks both ends · 8" long over buffers

= 7154 = 7164 = 60015

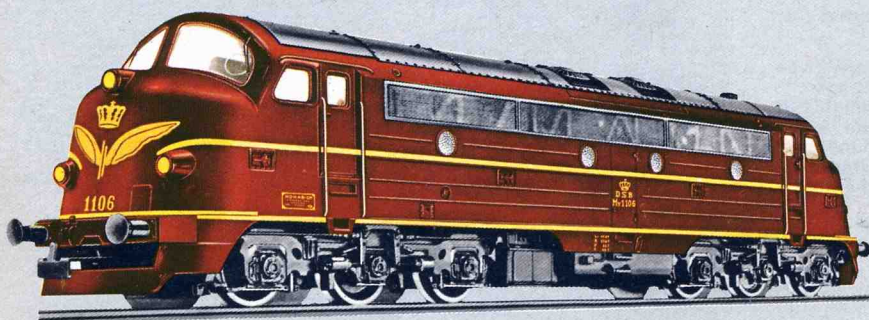

Danish Railways' diesel-electric locomotive 3067

The Danish State Railways' Serie My 1100 multi-purpose locomotive has diesel-electric drive, i. e. the current for the traction motors situated on the axles is produced by generators on the locomotive, the generators in turn being driven by diesel engines. Amongst other services, they haul international expresses over the direct "Vogelflug" connection (the line "as the crow flies"). This locomotive series is very similar to the Belgian Type 204.

3067 Diesel locomotive · A model of the Danish State Railways' (DSB) 0-6-6-0 (Ao 1 Ao) type My 1100 locomotive · 3 driven axles · 4 rubber tires to increase pulling power · Reversing by remote control · Three working headlights at each end · Reddish brown metal body · Fixed buffer beams · Grey roof · Inset

windows with plastic frames · Coupling hooks at both ends · 8" long over buffers

= 7154 = 7164 = 60015



Norwegian State Railways multi-purpose diesel electric locomotive 3068

Diesel operation is being used increasingly on the Norwegian State Railways' lines which are not yet electrified. The locomotive on which our model is based is known as type Di 3. Its 1900 HP motor gives it a top speed of 63 mph. Apart from the roof fittings, its relationship to the Belgian type 204 and Danish type My 1100 is unmistakable.

3068 Diesel locomotive · A model of the Norwegian State Railways' (NSB) 0-6-6-0 (Co-Co) Type Di 3 locomotive · 3 driven axles · 4 rubber tires to increase pulling power · Reversing by remote control · Three working headlights at each end · Reddish brown metal body · Fixed buffer beams · Silver colored roof and roof fittings · Inset windows with plastic frames ·

Coupling hooks at both ends · 8" long over buffers

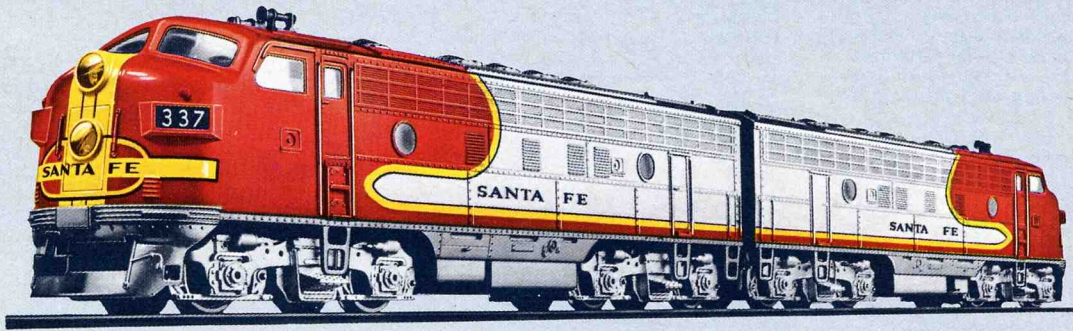

= 7154 = 7164 = 60015



American "F 7" diesel locomotive of the Atchison Topeka and Santa Fé Railroad



3060

3060 Diesel locomotive · A model of the American Type F 7 0-4-4-0 (Bo Bo) locomotive built by the Electro-Motive Division of General Motors for the Atchison Topeka and Santa Fé Railroad · 2 driven axles · 4 rubber tires to increase pulling power · Reversing by remote control · Scale model lighting · Red and silver metal body · Coupling hook with advance uncoupler at cab end · Automatic coupling with advance uncoupler (RELEX) at the trailing end · 6⁷/₈" long

 = 7154  = 7185  = 60015

4060

4060 Supplementary unpowered locomotive · Matching the diesel locomotive 3060 · Scale model lighting · Red and silver metal body · Coupling hook with advance uncoupler at cab end · 6⁷/₈" long

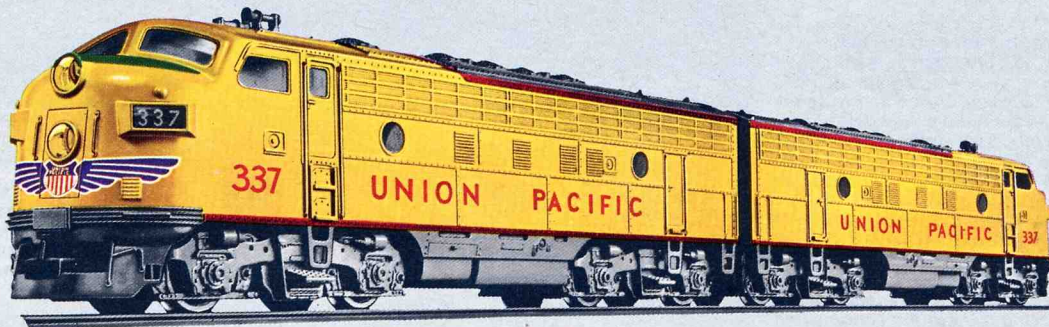

 = 7166  = 60015



American "F 7" diesel locomotive of the Union Pacific Railroad

3061

3061 Diesel locomotive · A model of the American F 7 0-4-4-0 (Bo Bo) locomotive built by the Electro-Motive Division of General Motors for the Union Pacific Railroad · 2 driven axles · 4 rubber tires to increase pulling power · Reversing by remote control · Scale model lighting · Yellow metal body · Coupling hook with advance uncoupler at cab end · Automatic coupling with advance uncoupler (RELEX) at trailing end · 6⁷/₈" long



 = 7154  = 7185  = 60015

4061



4061 Supplementary unpowered locomotive · Matching the diesel locomotive 3061 · Scale model lighting · Yellow metal body · Coupling hook with advance uncoupler at cab end · 6⁷/₈" long

 = 7166  = 60015

3016 Railbus · A model of the German Federal Railways 795 unit · 1 driven axle · 2 rubber tires to increase pulling power · Reversing by remote control · Three working headlights at each end · Interior lighting · Red plastic body · Die cast zinc frame · Symmetrical special couplings at each end for close-coupling the cars together · 5 7/8" long over buffers

 = 7153  = 7164  = 60010

4018 Railbus trailer · A model of the German Railways' 995 unit · Red tail lights at both ends · Interior lighting · Red plastic body · Symmetrical special coupling to fit railbus only · 4 3/4" long over buffers

 = 7175  = 60010

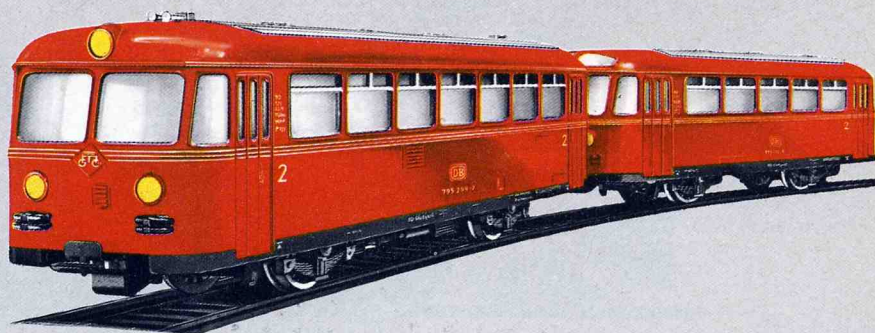

**3016 4018
Railbus with Trailer**



TRANS EUROP EXPRESS

Five complete trains of the Netherlands-Swiss TRANS EUROP EXPRESS are now in service, operating between Zurich and Amsterdam as the TEE "Edelweiss" and between Zurich and Munich as the TEE "Bavaria". Mostly they consist of four coaches. Three powerful diesel engines, developing together 2300 HP, give the train a speed of 87 1/2 mph. The windows in these trains do not open since all coaches are fully air conditioned. As on all TEE trains, there are only first class cars, each with 114 seats. The restaurant section has room for 32 diners.

The TEE train which has been modelled, consists of the 3-part unit 3071, which can be supplemented by the coach 4071 to bring it up to the composition customary on the railways. The length of the 4-unit train is 37 1/4".



**3071 4071
"TEE" Express Train**

3071 Three-unit TEE express train · A model of the Netherlands-Swiss TRANS-EUROP-EXPRESS train consisting of a locomotive, a combined first-class and restaurant car and a spacious first-class compartment car with engineers compartment · The model is 27 1/2" long

Locomotive: 3 driven axles · 4 rubber tires to increase pulling power · Reversing by remote control · Dull black die cast zinc underframe ·

Battery driven rail motor cars Class 515—usually coupled to trailer cars 815—are mostly used on main and secondary lines for express and local passenger services. Their range of operation is limited to about 200 miles by the capacity of the batteries carried as the source of power. Two motors each developing 270 HP give the train a top speed of about 60 mph. The motor car is 46 ft. in length and weighs 56 tons in service. The trailer is the same length and weighs 23 tons.

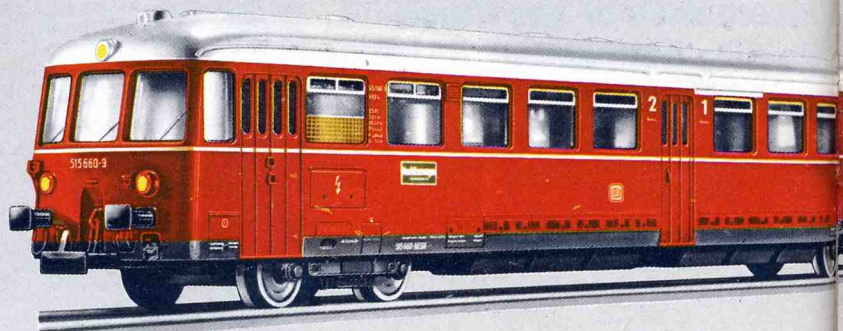

**3076
Electric motor railtrain**

3076 Two-unit electric railtrain · A model of the battery powered multiple train unit 515/815 of the German Federal Railways
Rail motor car: 2 driven axles · 4 rubber tires to increase pulling power · Reversing by remote control · Red plastic body · Interior fittings · Interior lighting · Inset windows with plastic

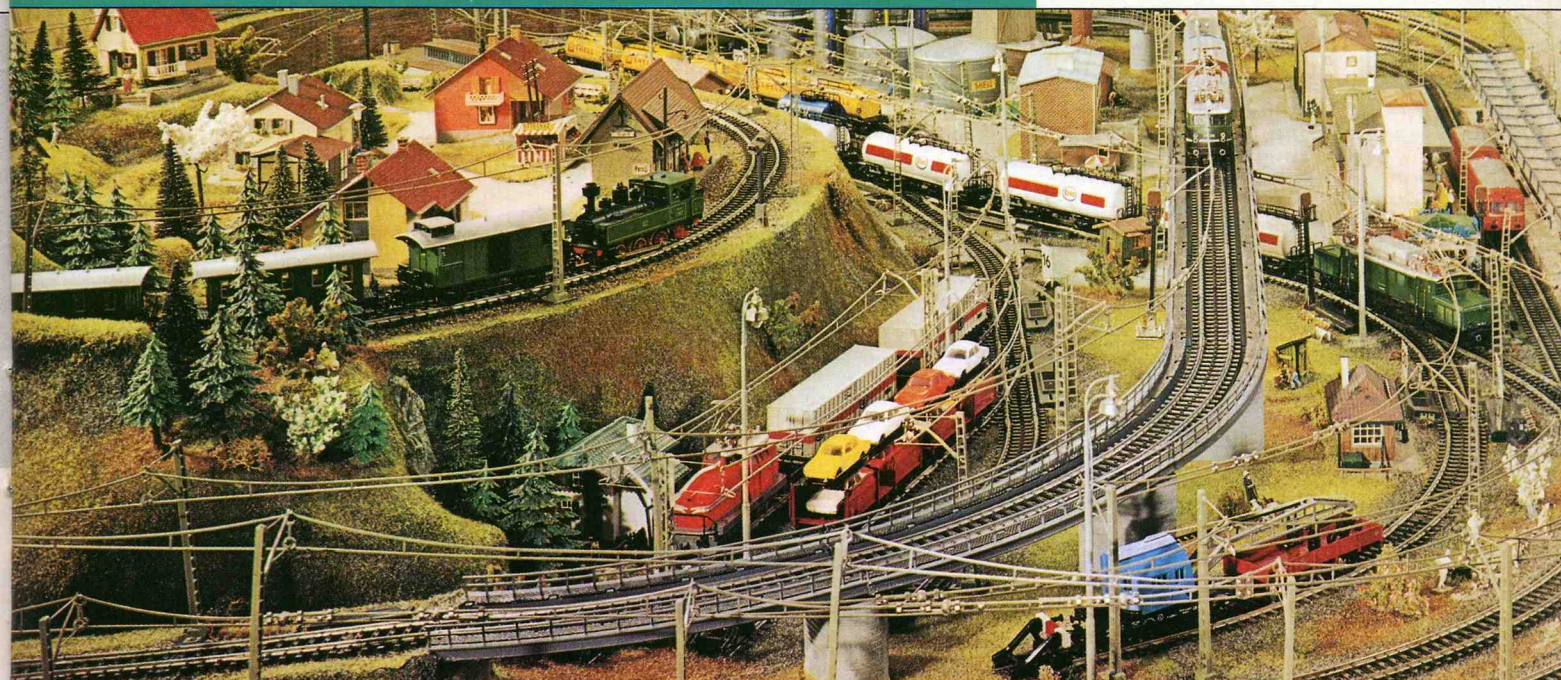

4071

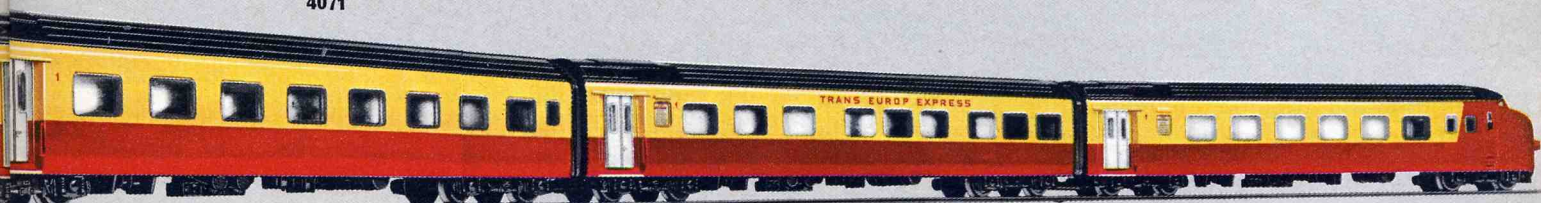



Plastic body in the TEE colors beige and red · Grey roof · Inset windows with plastic frames

The other two cars: each with two trucks like the originals · Plastic body in the TEE colors beige and red · Grey roof · Inset windows with plastic frames

Special couplings connect the 3 units very close together · Specially tightly closing covers on passage between cars · Three headlights and

two red taillights at each end of the train lighting up to suit the direction of the train · A current pickup shoe at each end of the train, the front one in the direction of travelling picking up the current



 = 7154  = 7164 7175  = 60015 w
60001 r

4071 TEE First class compartment coach · 2 trucks true to the original · Grey roof · Inset windows with plastic frames · Movable covers for the corridor between coaches at each end · Special coupling fitting the TEE train only · 9" long



frames · Aluminum colored roof
Trailer car: Connected to the motor car by permanent coupling · Red plastic body · Interior fittings · Interior lighting · Inset windows with plastic frames · Aluminum colored roof
Motor car and trailer each have three headlights

working when running forward changing automatically to two red lights when reversed · Coupling hooks at both ends of train · 19½" long over buffers

 = 7154  = 7164 7175  = 60015 w
60001 r

HAMO

8376

The same model as 3076, but for two-rail D.C. operation (see page 25)



TEE coaches with interior fittings

Here we have the "showpiece" of the German Federal Railways, the TEE coaches. They are the best equipped, the most comfortable and undoubtedly the most handsome coaches of the German Federal Railways.



4085

4085 TEE compartment coach · First class · A model of the German Federal Railways' type Avm · Windows inset in plastic frames · **Interior fittings** with side corridor · Length 9 1/2" · Arranged for the interior lighting set 7320 (see page 62)

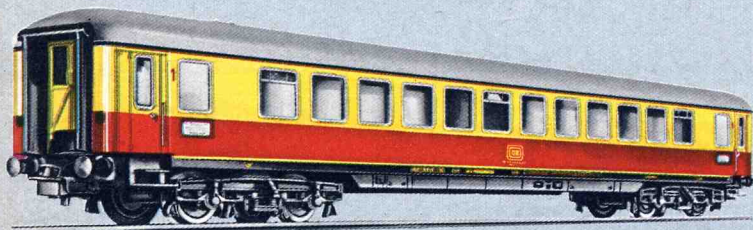

4086

4086 TEE open interior coach · First class · A model of the German Federal Railways' type Apm · Windows inset in plastic frames · **Interior fittings** with the 1-2 seating arrangement and centre corridor · 9 1/2" long · Arranged for interior lighting set 7320 (see page 62)



4087

4087 TEE restaurant car · A model of the German Federal Railways' type WRm · Windows inset in plastic frames · **Interior fittings**, divided into kitchen and restaurant compartments · 9 1/2" long · Arranged for the interior lighting set 7320 (see page 62)



4088

4088 TEE bar car · A model of the German Federal Railways' type ARDm · Windows inset in plastic frames · **Interior fittings**, divided into bar, passenger and train crew's compartments · 9 1/2" long · Arranged for interior lighting set 7320 (see page 62)

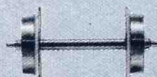
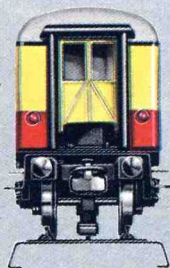

4089

4089 TEE compartment coach · As coach 4085, but with current pickup, fittings for interior lighting and tail lights

7589

MÄRKLIN-HAMO for two rail D.C. operation
Set of wheels · Consisting of 4 axle sets · For converting the TEE coaches for two-rail D.C. operation



4090

4090 TEE observation coach · First class · A model of the German Federal Railways' type ADm · Windows inset in plastic frames · **Interior fittings** · Observation dome of transparent plastic · 9 1/2" long · Arranged for interior lighting set 7322 (see page 62)

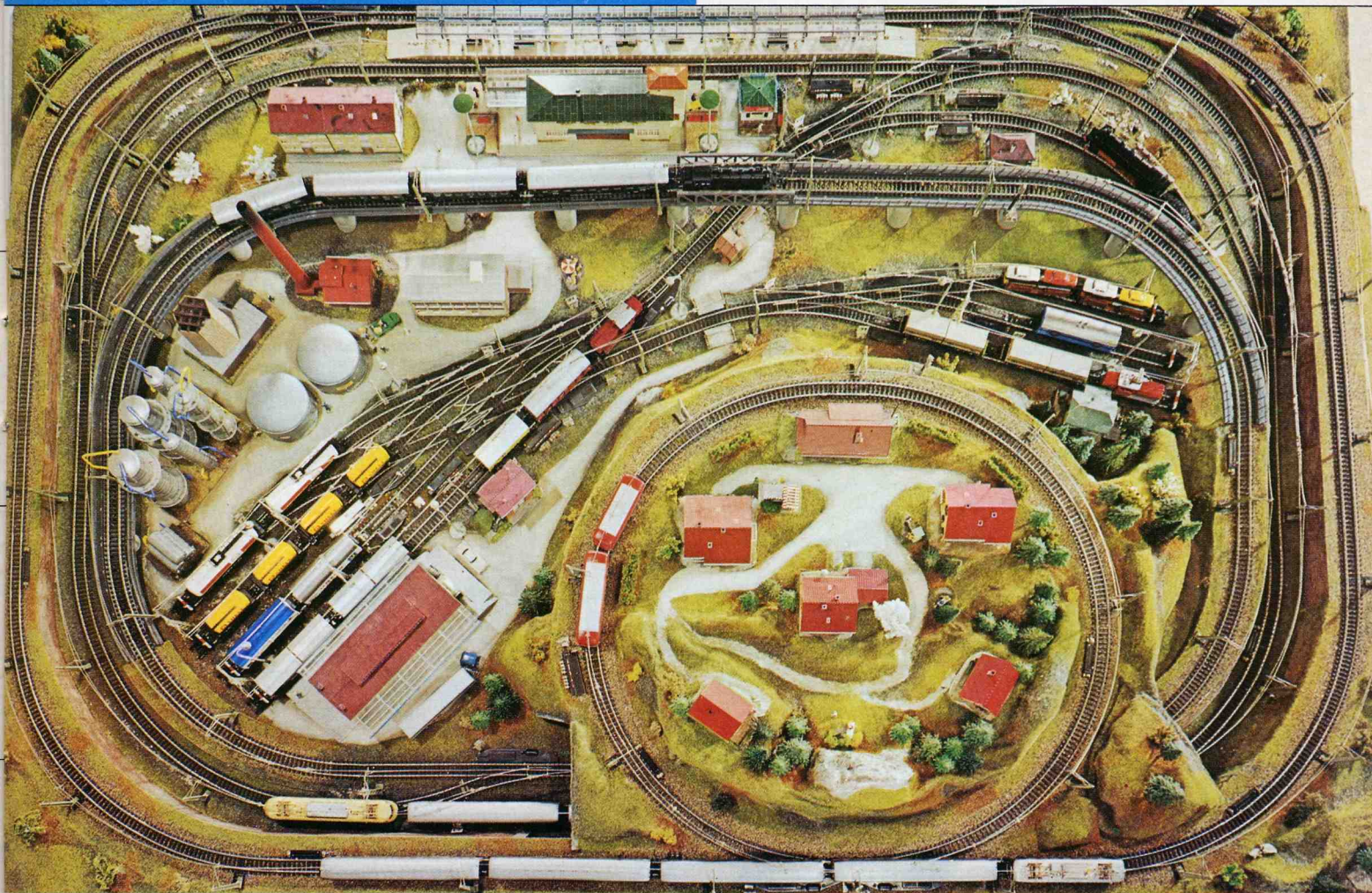

Local passenger coaches of the German Federal Railways with interior fittings



With baggage compartment and driver's cab

4081

4081 Local passenger coach with baggage compartment and driver's cab · 2nd class · A model of the

German Federal Railways' type BDnf · Body of stainless steel color with peacocks-eye pattern · **Interior fittings** · Windows with plastic frames · Roof with dummy signal horn · Headlights on the driver's cab end, which change automatically from three white lights when running forwards to two red lights when running in reverse · 9 1/2" long · Arranged for interior lighting set 7077 (see page 62)



4082

4082 Local passenger coach · 2nd class · A model of the German Federal Railways' type Bnb · Body of stainless steel color with peacocks-eye pattern · **Interior fittings** · Windows with plastic frames · 9 1/2" long · Arranged for the interior lighting set 7077 and current pickup shoe 7198 (see page 62)



4083

4083 Local passenger coach · 1st and 2nd class · A model of the German Federal Railways' type ABnb · Body of stainless steel color with peacocks-eye pattern · **Interior fittings** · Windows with plastic frames · 9 1/2" long · Arranged for interior lighting set 7077 and current pickup shoe 7198 (see page 62)

Express coaches of the German Federal Railways

Our express coaches all have metal or plastic bodies. Plastic window frames and panes are inserted separately. Door recesses and other important details and the fine, indelible lettering are true to the original. Their mat finish makes them look completely realistic. Ready for interior lighting. The Minden-Deutz design trucks have movable side frames which even out any irregularities in the track so that the coaches run safely and very quietly. Simulated rubber beading or bellows are fitted at each end where the coaches join up. Automatic coupling with advance uncoupling (RELEX).

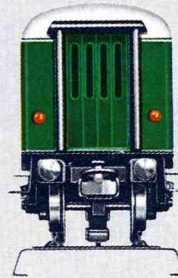
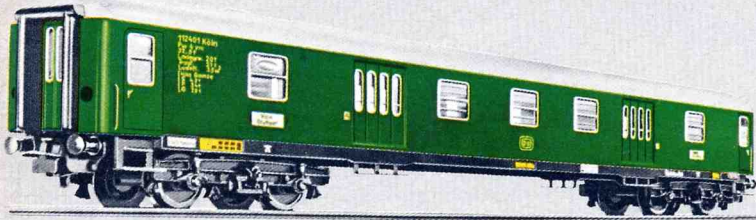

4026 4044

4026 Express baggage car · A model of the German Federal Railways' type D ym · Windows inset in plastic frames · 9 1/2" long · Arranged for interior lighting set 7077 and current pickup shoe 7198 (see page 62)

4044 Express baggage car · Similar to 4026 but with tail lights and pickup shoe



4029

4029 Express sleeping car · A model of the International Sleeping Car Company's type ISG No. 4581 · Windows inset in plastic frames · 9 1/2" long · Arranged for interior lighting set 7077 and current pickup shoe 7198 (see page 62)



4037

4037 Express coach · Second class · A model of a German Federal Railways' older type · Plastic windows · 8 1/2" long · Arranged for interior lighting set 7077 and current pickup shoe 7198 (see page 62)



4064

4064 Express sleeping car · 1st and 2nd class · A model of the German Sleeping and Restaurant Car Company's car of type WL AB um Series 33200 · Windows inset in plastic frames · 9 1/2" long · Arranged for interior lighting set 7320 (see page 62)



4078

4078 Express coach · 1st class with restaurant compartment · A model of the German Federal Railways' type AR um 65 · 1st class compartment finished in blue on the outside, the restaurant compartment in red. Windows inset in plastic frames · 9 1/2" long · Arranged for the interior lighting set 7320 (see page 62)

Interior fittings for coaches 4037, 4045, 4065, 4066, 4069 and 4075

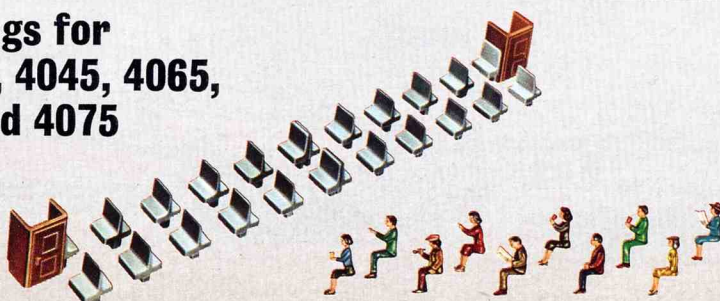

0225 0226

0225 Set of interior fittings for express coaches with 18 single-color double seats, 6 single seats and 2 toilet compartments

0226 Set of 10 brightly painted passenger figures, to supplement the interior fittings

Interior fittings and figures are of finely detailed plastic, the figures being hand painted. Illustrated installation instructions are included with each set.

MÄRKLIN HO Express coaches

**9 1/2", 10 2/3" long
with interior fittings**



4051 **NEW**

4053 **NEW**

4051 Express coach · 1st class · A model of the German Federal Railways' type A üm · **Interior fittings** · Windows inset in plastic frames · 9 1/2" long · Arranged for interior lighting set 7077 and current pickup shoe 7198 (see page 62)

4053 Express coach · Similar to 4051, but with tail lights and current pickup shoe

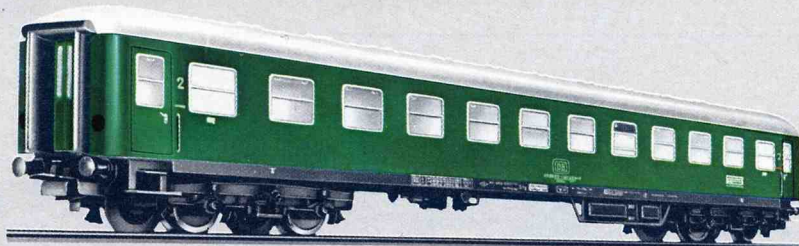

4052 **NEW**

4052 Express coach · 2nd class · A model of the German Federal Railways' type B üm · **Interior fittings** · Windows inset in plastic frames · 9 1/2" long · Arranged for interior lighting set 7077 and current pickup shoe 7198 (see page 62)



4054 **NEW**

4054 Express restaurant car · A model of the German Federal Railways' type WR üm 132 · **Interior fittings**, divided into kitchen and restaurant compartments · Windows inset in plastic frames · 9 1/2" long · Arranged for interior lighting set 7320 (see page 62)



4091 **NEW**

*Long version
10 2/3"*

4091 Express coach · 1st class · A model of the German Federal Railways' type A üm 201 · Plastic body · **Interior fittings** · Windows inset in plastic frames · 10 2/3" long · Arranged for interior lighting set 7324 (see page 62)



4092 **NEW**

*Long version
10 2/3"*

4092 Express coach · 2nd class · A model of the German Federal Railways' type B üm 234 · Plastic body · **Interior fittings** · Windows inset in plastic frames · 10 2/3" long · Arranged for interior lighting set 7324 (see page 62)



4093 **NEW**

*Long version
10 2/3"*

4093 Express baggage car · A model of the German Federal Railways' type D üm 902 · Plastic body · At the sides, **movable roller shutters** · Windows inset in plastic frames · 10 2/3" long · Arranged for interior lighting set 7324 (see page 62)



4094 **NEW**

*Long version
10 2/3"*

4094 Express restaurant car · A model of the German Federal Railways' type WR ümh 132 · Plastic body · **Interior fittings**, divided into kitchen and restaurant compartments · Windows set in plastic frames · 10 2/3" long · Arranged for interior lighting set 7324 (see page 62)

Lightweight coaches of the Swiss Federal Railways



4066

4066 Passenger coach · A model of the Swiss Federal Railways' 1st class coach of Series A 2500 · Windows inset in plastic · Roof with longitudinal ribs and simulated vents · 9 1/2" long · Arranged for interior lighting set 7320 (see page 62)



4068

4068 Express restaurant car · A model of the RIC restaurant car of the Swiss Federal Railways · Windows inset in plastic frames · Screwed-on roof with longitudinal ribs · 9 1/2" long · Arranged for the interior lighting set 7077 (see page 62)

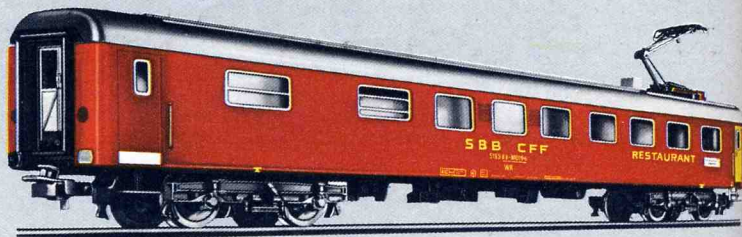

Italian express coach with interior fittings



4063 **NEW**

4063 Express coach · 1st class · A model of the Italian State Railways' type FS Az · **Interior fittings** · Windows set in plastic frames · 9 1/2" long · Arranged for interior lighting set 7077 and current pickup shoe 7198 (see page 62)



Express coaches of the French National Railways



4050

4050 Express coach · 1st class · A model of the French National Railways' stainless steel express coach, type A 8 myfi · Plastic body · Windows inset in plastic frames · 9 1/2" long · Arranged for interior lighting set 7197 (see page 62)



4065

4065 Express couchette car · A model of the 2nd class standard UIC model type Y on the French National Railways · Windows inset in plastic frames · 9 1/2" long · Arranged for interior lighting set 7320 (see page 62)

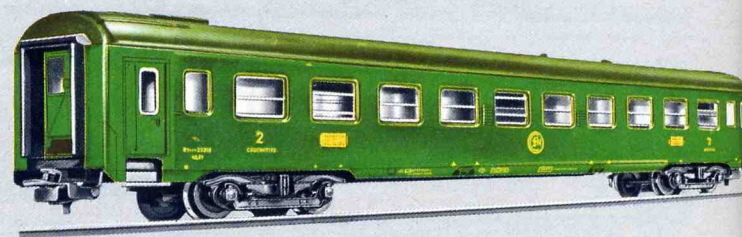

The passenger and express coaches on pages 38/39 are fitted with automatic coupling and advance uncouplers (RELEX).

4075

4075 Express coach · 1st class · A model of the French National Railways "Capitole" class · Windows inset in plastic frames · 9 1/2" long · Arranged for interior lighting set 7320 (see page 62)

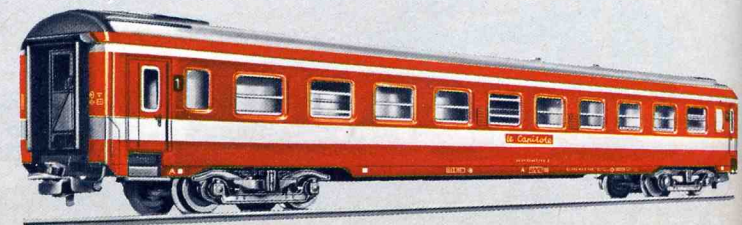



Express coaches of the Netherlands Railways



4048

4048 Express mail van · A model of the Netherlands Railways' type P 7900 · Windows inset in plastic frames · 9 1/2" long · Arranged for interior lighting set 7320 (see page 62)

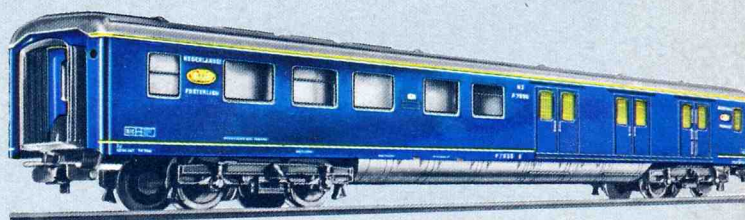

4049

4049 Express coach with seating accommodation · 2nd class · A model of the Netherlands Railways' type B 6600 · Windows inset in plastic frames · 9 1/2" long · Arranged for interior lighting set 7320 (see page 62)



Express coaches of the Swedish State Railways



4072

4072 Express coach · 2nd class · A model of the Swedish State Railways' type Bo 1) · Plastic body · Windows inset in plastic frames · 9 1/2" long · Arranged for interior lighting set 7197 (see page 62)

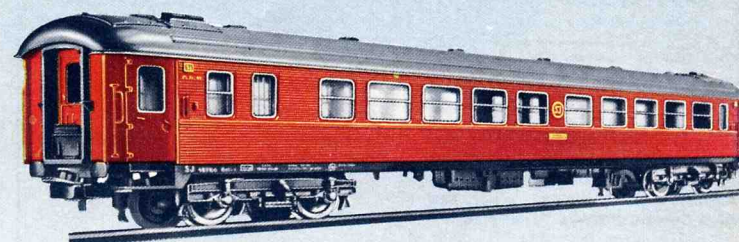

4073

4073 Express restaurant car · A model of the Swedish State Railways' type RBo 2 · Plastic body · Windows inset in plastic frames · 9 1/2" long · Arranged for the interior lighting set 7197 (see page 62)

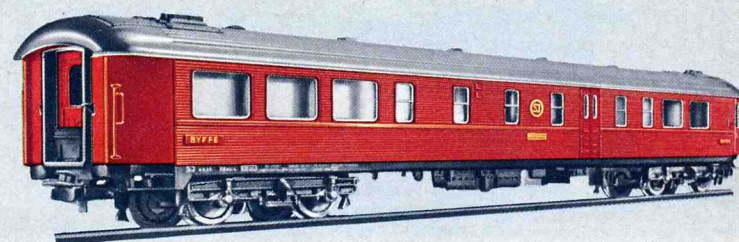

Express coach of the Belgian National Railways



4069

4069 Express couchette car · 2nd class · A model of the Belgian National Railways' RIC-couchette car · Roof with simulated vents · Windows inset in plastic frames · 9 1/2" long · Arranged for the interior lighting set 7320 (see page 62)

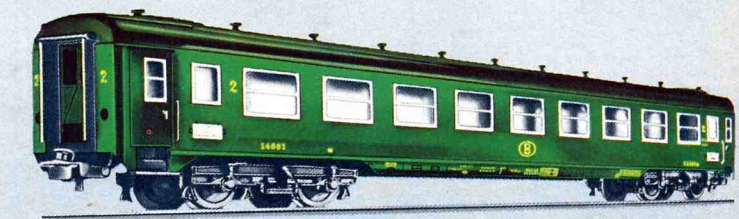

Express coach of the Danish State Railways



4045

4045 Express coach · 2nd class · A model of the Danish State Railways' type B 2300 · Windows inset in plastic frames · 9 1/2" long · Arranged for interior lighting set 7077 and current pickup shoe 7198 (see page 62)

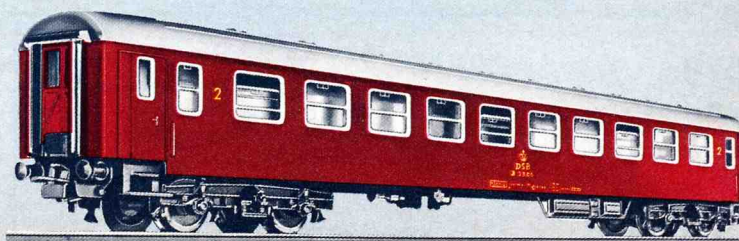

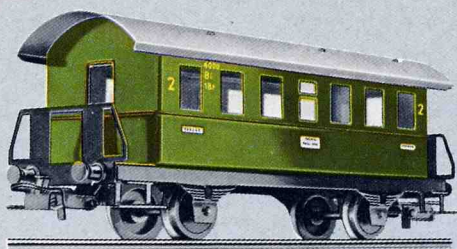

4000

4000 Passenger coach · Platform and door at each end · Open windows · 4 ½" long



4004

4004 Compartment coach without brakeman's cabin · Sides opening into 6 compartments · Windows glazed with cellophane · 5 ¼" long · Arranged for interior lighting set 7074 (see page 62)

4005

4005 Compartment coach with brakeman's cabin · Sides opening into 6 compartments · Windows glazed with cellophane · 5 ¼" long · Arranged for interior lighting set 7074 (see page 62)

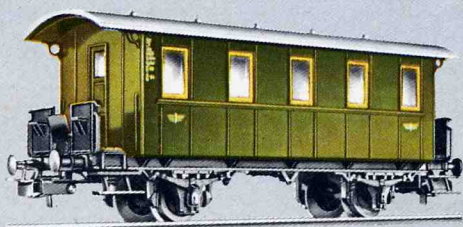

4007

4007 Passenger coach · Modelled on a private railway coach · Platform and door at each end · Plastic body · Simulated roof air vents · Windows inset in plastic frames · **Interior**

fittings · 4 ¼" long · Arranged for interior lighting set 7323 (see page 62)

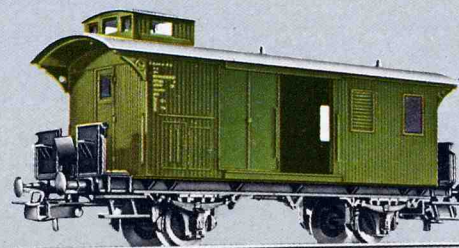

4008

4008 Baggage car · Modelled on the Stuttgart Railways private car No. 0116911 · Platform and door at each end · Plastic body · Simulated air vents and superstructure for the

train drivers compartment · 4 ¼" long · Arranged for interior lighting set 7323 (see page 62)

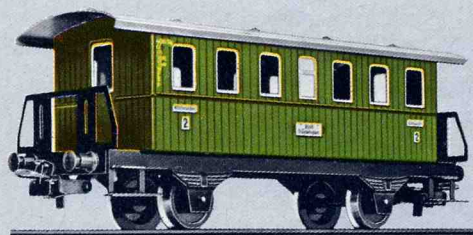

4040

4040 Passenger coach · Platform and door at each end · Cut-out windows · 4 ½" long

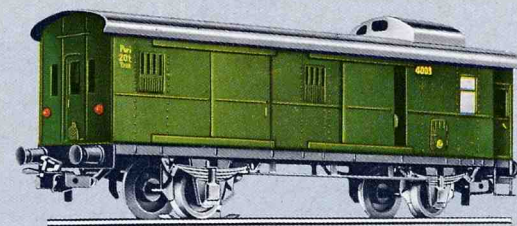

4041

4041 Baggage car · Modelled on the German Federal Railways' type Di 28 · **Sliding doors on both sides** · Roof superstructure for train driver's compartment · Tail lights and current pickup shoe · 5 ½" long

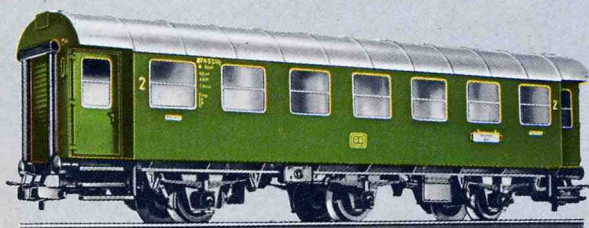

4079

4079 Passenger coach · A model of the German Federal Railways' type B3yge · Plastic body · Windows inset in plastic frames · Imitation

rubber beading · 6" long · Arranged for interior lighting set 7074 (see page 62)



4080

4080 Passenger coach with baggage compartment · A model of the German Federal Railways' type BD3yge · Plastic body · Windows

inset in plastic frames · Imitation rubber beading · 6" long · Arranged for interior lighting set 7074 (see page 62)



Freight cars with plastic bodies and automatic couplers and advance uncouplers (RELEX, see page 42)

The underframes of all these cars are made of metal and painted dull black. The wheels are zinc die castings. Bodies are made of plastic. All the lengths quoted are measured over the buffers.



4500
4500 Tank car · ARAL · 4" long



4501
4501 Tank car · ESSO · 4" long



4502
4502 Tank car · SHELL · 4" long



4503
4503 Low side car · 4" long



4504
4504 Low side car · Loaded with miniature automobiles · 4" long

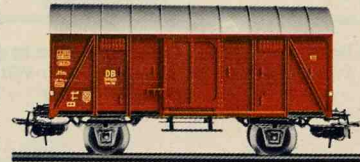

4505
4505 Box car · 4" long



4506
4506 Box car · Finely modelled side tail lights with bulbs · Current pickup shoe · 4" long

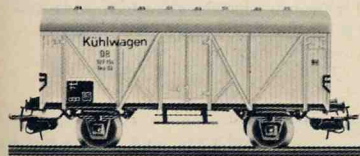

4508
4508 Refrigerator car · 4" long

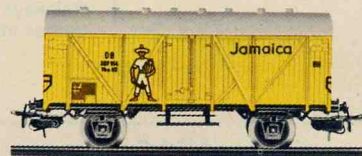

4509
4509 Banana car · 4" long

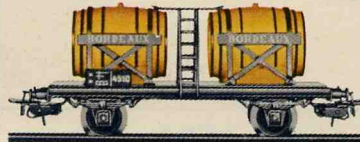

4510
4510 Wine car · 4" long



4511
4511 Pulverised coal car · 4" long

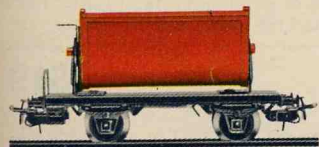

4513
4513 Dump car · Will dump to either side · Locking lever · 3 3/8" long

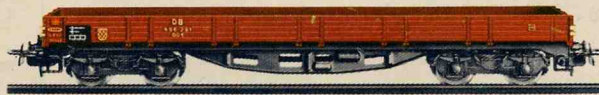

4514
4514 Low side car · 7 1/4" long



4517
4517 Covered flat car · 7 1/4" long

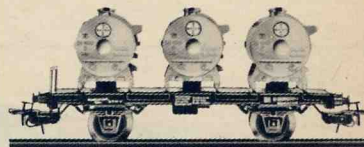

4520
4520 Chemical container car · BAYER · Containers can be removed by the crane 7051 · 4 1/4" long



Scale model freight cars with automatic coupling and advance uncoupling (RELEX)

We have specially worked out the details of these models. The RELEX coupling is of particular importance in achieving realistic switching. When the coupling is opened by the uncoupling track, the coupling stays open so that the cars can be pushed away or can roll down a ramp.

4600

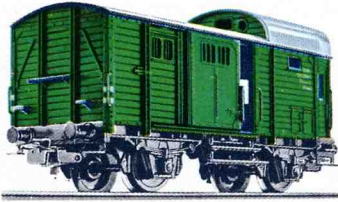

4600 Freight train baggage car (German Federal Railways' type DB-Dg) · Doors which can be opened on both sides · 3⁷/₈" long

4601

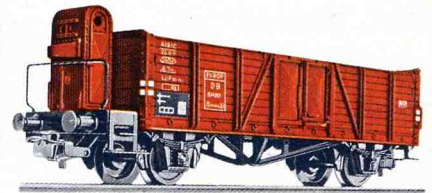

4601 Open freight car with brakeman's cab (German Federal Railways' type DB-Omm 33) · 4¹/₂" long

4602



4602 Open freight car (German Federal Railways' type DB-Omm 52) · 4¹/₂" long

4604



4604 Open freight car (German Federal Railways' type DB-Omm 52) · With removable load simulating coal · 4¹/₂" long

4605

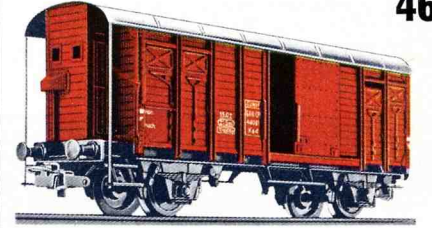

4605 Box car with brakeman's cab of the Swiss Federal Railways (type SBB-K³) · Doors which will open on both sides · 4¹/₂" long

4607

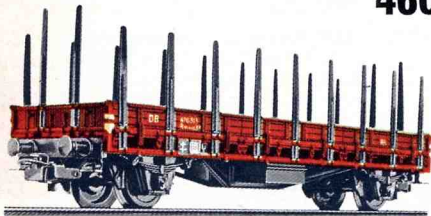

4607 Low side car with stakes (German Federal Railways' type DB-Rmms 33), with removable stakes, which can be stored in sliding case underneath car floor · 5" long

4610

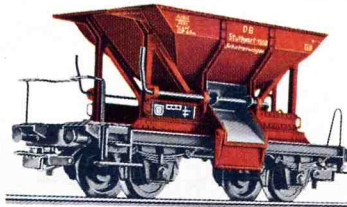

4610 Ballast car with unloading doors operated by hand lever · 3³/₄" long

4612



4612 Automobile transporter with loading ramp · Not loaded · 4¹/₂" long · (On the German Federal Railways, 2 transporters are always joining together into a single unit known as Off 52)

4611

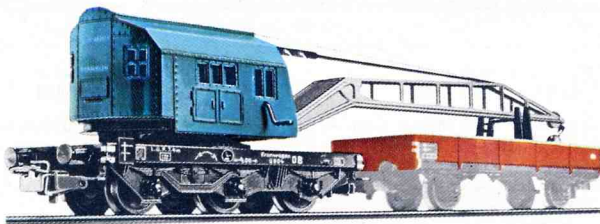

4611 Crane car with slewing crane, with movable boom and boom support · Crank handle to raise and lower the crane hook · Underframe 3⁷/₈"

long · (The low side car 4503 is not included in the price but is recommended when the crane car is being moved)

4613



4613 Automobile transporter with loading ramp · Loaded with miniature automobiles · 4¹/₂" long

4617

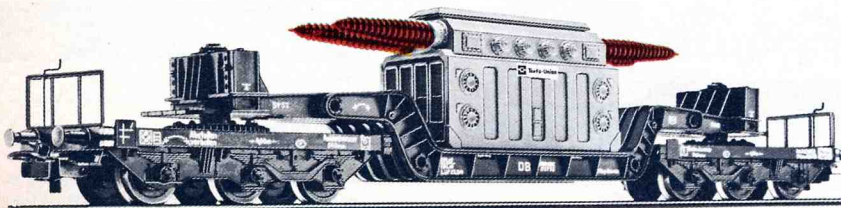

4617 Depressed center flat car · Loaded with a transformer · 10" long

4619



4619 Sliding roof car (German Federal Railways' type DB-Kmmks 51) · Roof halves which slide open · 4¹/₂" long

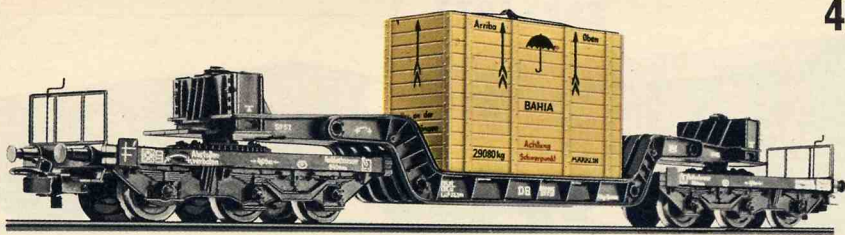

4618

4618 Depressed center flat car · Loaded with crate · 10" long



4621

4621 High capacity tank car · A model of the German Federal Railways' type Ksl 3504 · 5 1/8" long



4624

4624 High capacity goods car · A model of the German Federal Railways' type OOtz 50 · 5 1/4" long

Cars of this type are used in international traffic for carrying coal, coke, ore, etc. They are usually made into trains which are not broken up till they reach their final destination.



4626

4626 High capacity freight car with hinged roof covers · A model of the German Federal Railways' type Kkt 57 · All the covers will open · 5 1/4" long

On a number of high capacity freight cars, fixed covers are fitted so that bulk materials liable to be affected by the elements e.g. grain, can be transported.

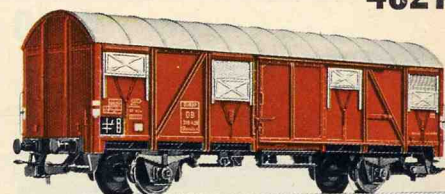

4627

4627 Box car · A model of the German Federal Railways' type Gimmehs 57 · 5 1/4" long

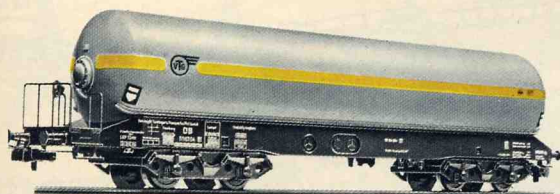

4628

4628 Pressurised gas tank car · Version used by the Vereinigte Tanklager und Transportmittel GmbH (VTG) · 7 3/4" long



4632

4632 Beer tank car · 7 3/4" long

MÄRKLIN-HAMO Sets of wheels

for two-rail D. C. operation

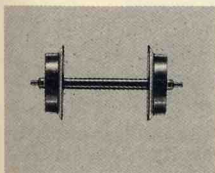

7587

7587 Wheel set, consisting of 3 axle sets · For converting the cars 4611, 4617 and 4618 to two-rail D.C. operation

7588

7588 Wheel set, consisting of 4 axle sets · For converting all cars of the 4600 series (except 4611, 4617, 4618, 4631, 4633, 4635, 4644, 4646, 4656, 4657, 4659, 4664 and all freight cars with 4 axles) to two-rail D.C. operation



4631

4631 Side dumping car with opening doors · A model of the German Federal Railways' type Otm 70 · 4 1/2" long

The discharging doors can be opened by the hand lever or by remote control using the uncoupling track sections 5112 (page 48) and 2197 (page 52).

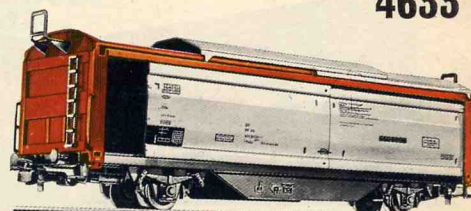

4633

4633 Freight car with sliding doors and roof (German Federal Railways' type DB-Klimgks 66) · The roof halves and side-wall halves slide open · 6 1/2" long



4634

4634 Beer tank car · A model of a private car belonging to the Dortmunder Union Brewery · Roof with simulated ventilators · 5 1/4" long

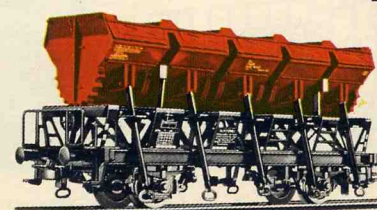

4635

4635 Dump car · A model of the German Federal Railways' type Omni 51 · Tips after the centre holding bar is unfastened · 4 1/2" long



Scale model freight cars with automatic coupling and advance uncoupling (RELEX, see page 42)

4637



4637 Box car · A model of the German Federal Railways' type Tnomehs 59 · 5 ¼" long

4639



4639 Open freight car · A Netherlands State Railways' model · 4 ½" long

4640

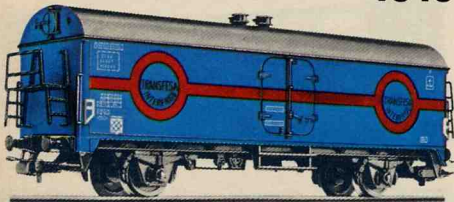

4640 Refrigerator car · A model of a car belonging to the transport firm TRANSFESA · Roof with simulated ventilators · 5 ¼" long

4644



4644 Tank car · A model of the standard tank car with "BP" markings · 4" long

4646



4646 Tank car · A model of the standard tank car with ARAL markings · 4" long

4649



4649 Tank car · AVIA · 6 ½" long

4650

NEW



4650 Tank car · ESSO · 6 ½" long

4656

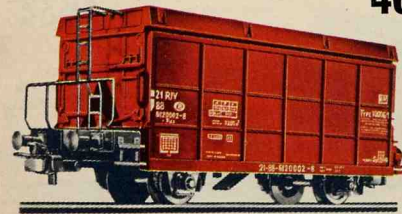

4656 Open freight car · A model of the Belgian National Railways' type 1000 G-1 · 4" long
The sides can be opened by using the uncoupling track section 5112 (see page 48) and 2197 (page 52).

4657

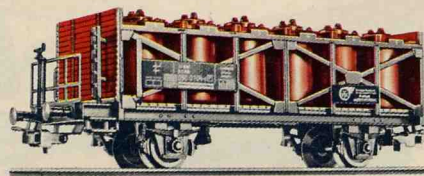

4657 Acid container car · A model of a German Federal Railways' container carrying car · 12 scale model plastic acid containers · 4 ½" long

4658



4658 Container car for fine bulk goods · A model of the German Federal Railways' type Kds 54 in use as a private car of the Franken Sugar Co. · 4" long

4659



4659 Container car · A model of the German Federal Railways' type "Berlin" container car · Loaded with 2 removable containers · 6 ½" long

4660



4660 Beer car · A model of a car owned by the Kulmbacher-Mönchshof Brewery · Roof with simulated ventilators · 5 ¼" long

4550

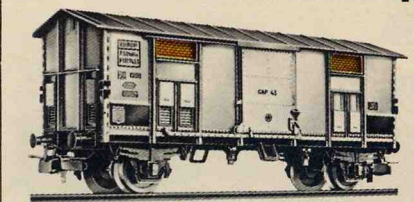

4550 Box car · An Italian State Railways' model · 4 ½" long



4663

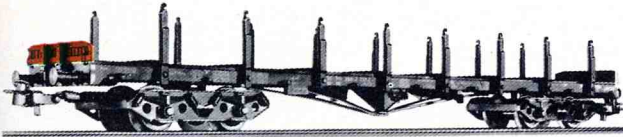

4663 Flat car · A model of the German Federal Railways' type SSI mas 53 · Die cast metal body · Side stanchions fold down · 9" long

4664

NEW

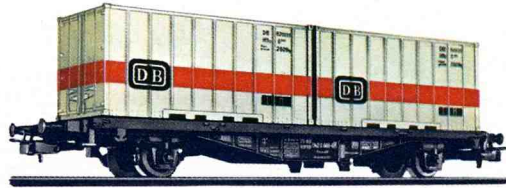

4664 Container car · A model of the German Federal Railways' type "Berlin" container car · Loaded with 2 removable containers · 6 1/8" long

4666

NEW



4666 Beer car · A model of a car owned by the Würzburger Hof Brewery · Roof with simulated ventilators · 5 1/4" long

MÄRKLIN-HAMO Wheel sets

for two-rail D. C. operation

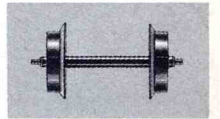

7587 Wheel set, consisting of 3 sets of axles · For converting the cars 4611, 4617 and 4618 for two-rail D.C. operation

7588 Wheel set, consisting of 4 sets of axles · For converting all type 4600 cars (except 4611, 4617, 4618, 4631, 4633, 4635, 4644, 4646, 4656, 4657, 4659, 4664 and all 4-axle freight cars) for two-rail D.C. operation

7587

7588



American freight cars

4575



4575 Gondola · A "Dixie" Line model · 8" long

4571



4571 Box car · A Western Pacific Railroad 50-ton model · Roofwalk mounted on roof · Doors which open on both sides · 8 1/8" long

4576



4576 Caboose · Roof superstructure, with walkway and ladders · 3 1/8" long

4573

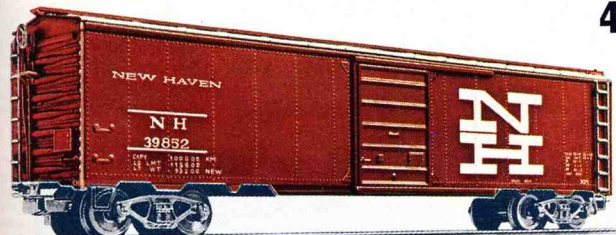

4573 Box car · A New Haven Railroad 50-ton model · Roofwalk mounted on roof · Doors which open on both sides · 8 1/8" long

4577

NEW



4577 Caboose · Roof superstructure, with walkway and ladders · 3 1/8" long

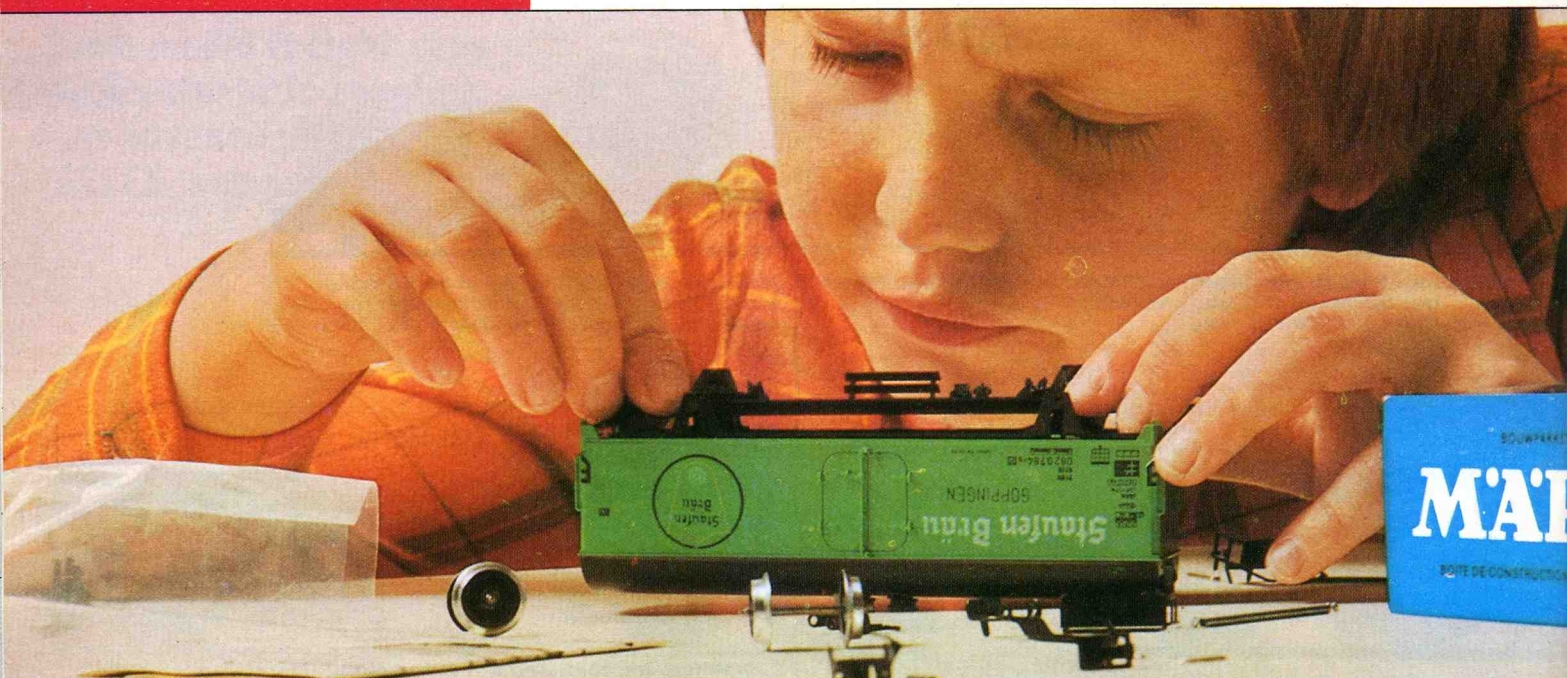

Car kits

These car kits enable you to build your own cars. Each kit includes the necessary illustrated instructions and all the kits include automatic couplers and advance uncouplers (RELEX). To assemble them, the only tools needed are a screwdriver and a pair of pliers, with a hammer in addition for car 4902.

4912

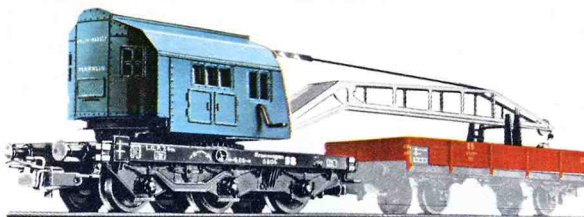

4912 Derrick car kit
Assembled kit 4912

4902



4902 Open freight car kit
Assembled kit 4902

4917

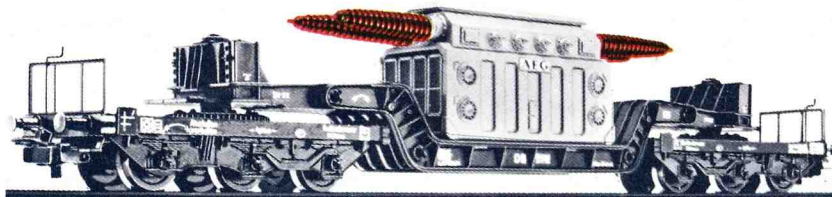

4917 Depressed center flat car kit
Assembled kit 4917

4918



4918 Refrigerator car kit
Assembled kit 4918

4921

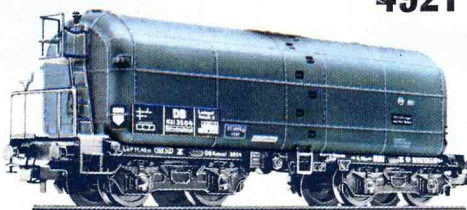

4921 Tank car kit
Assembled kit 4921

4934



4934 Beer car kit
Assembled kit 4934

4937

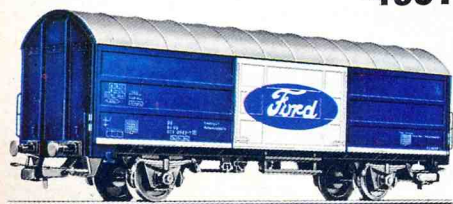

4937 Box car kit
Assembled kit 4937

4950



4950 Box car kit
Assembled kit 4950

4802



4802 Passenger coach kit
Assembled kit 4802



MÄRKLIN M-track (M = metal) for a trouble-free layout

Here we show our proven metal track. The special feature of this track is the covered current conductor in the roadbed with stud contacts projecting through the ties at the center of the track. The long current collectors between the wheels of the locomotives slide over these contacts.

Each track section consists of the road bed, which looks very realistic with its rock ballast and strong ties, and the two rails which are electrically connected to the roadbed. At the opposite ends of each track is a joiner.

The current-carrying rail has spring contact tongues at both ends, which lock together when the track sections are joined, the joiners mentioned sliding over the outer rails at the same time. The result is the reliable electrical contact which is a mark of the MÄRKLIN system and at the same time the track sections are held mechanically firmly together.

The screws needed for mounting the track when using sound deadening strips 7171 (see page 50) are included. When the sound deadening strips are not used, we recommend using the screws 7299 (see page 48).



How the different MÄRKLIN track circles compare

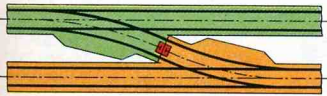

Fig. 1

Fig. 1
One section of track can be insulated from another by means of the insulator piece 5022 (see page 51), or a piece of ordinary cardboard. **No special insulating track section** is needed, so space is saved.

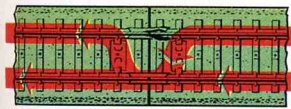

Fig. 2

Fig. 2
A special feature of the MÄRKLIN track is the **excellent current feeding qualities**. When one of the rail joiners is bent, which can always happen on a model railroad, this has no effect because the second joiner will still join the track sections and make electrical contact perfectly satisfactorily. No soldered joints are needed.

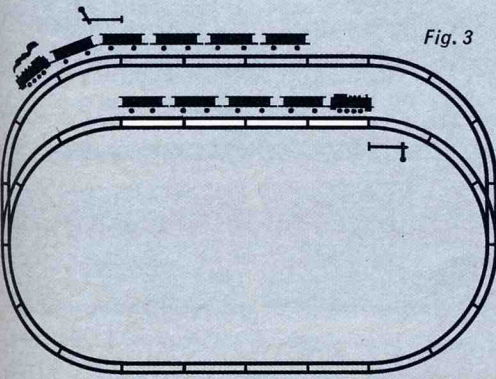

Fig. 3

Fig. 3
On track layouts with sidings or branches off the main line, locomotives or trains can run in the same direction or in opposite directions. No special reversing arrangement is necessary. There is no need to switch over the terminals on the transformer. This is one of the advantages of the MÄRKLIN system.

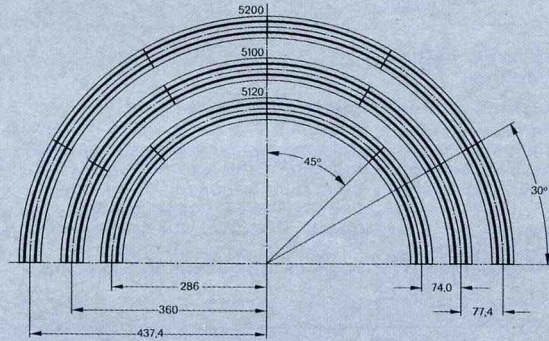

Fig. 4

Fig. 4
This drawing shows the different MÄRKLIN track circles with their radii, track intervals and angles and also the number of track sections required for a half circle.

- 1 circle of 5200 = 12 sections
- 1 circle of 5100 = 12 sections
- 1 circle of 5120 = 8 sections

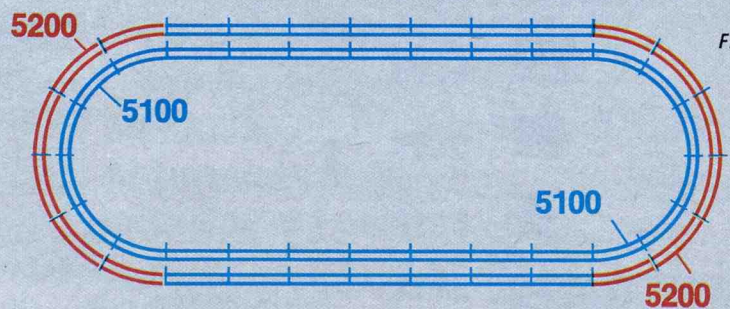

Fig. 5

Fig. 5
Track sections of the 5200 series are for extending an existing layout made up of 5100 series track. They enable concentric circles to be laid with a track center spacing of 3" (measured from contact stud to contact stud) and an operating clearance

between the two tracks of 1 1/4". The 5202 turnouts are used to cross from the inner to the outer loop. The construction of the 5200 track sections is similar to that of the 5100 series (wholly metal construction with contact studs).



Curved track sections 5100 for standard circle

Twelve 5100 track sections form a circle with outside diameter of 30".



5100 Full length = 30"



5101 Half length = 15"



5102 Quarter length = 7°30'



5103 Feeder track section, curved · Full length = 30" · 2 connecting cables

Switching track sections

The switching track sections (5146, 5147) are only half as long as the contact track sections and so save space. Moreover they can trigger one function in each direction of travel, i.e. two

in all; they can do this at the same time on one or more magnetically operated items. The switching track sections are operated from the current pickups on the locomotives.



5147 Switching track section, curved · Half length = 15"

Contact track sections

When travelling over a contact track section (5104, 5105), a train can operate signals, turnouts and other solenoids in front of it or behind it, electrically, by remote control. It does not matter which direction it is travel-

ling in. It can however always trigger only one switching operation on one or more signals or turnouts at the same time. Separate contact track sections are required e.g. to switch on signal to green and to red.



5104 Contact track section, curved · Full length = 30"

Track with small radius for branch lines and industrial sidings

5120 Curved track section · Full length = 45" · 8 track sections form a circle with an outside diameter of 24" · Even the big MÄRK-

LIN locomotives and coaches can negotiate this curve · Only if there is a direct reverse curve, at least one full length straight track section must be interposed, for a locomotive like the 3047 or an express coach · The 5120 track sections can be used in conjunction with all types of turnout and track sections



Straight track sections 5100



5106 Full length = 7"



5107 Half length = 3 1/2"



5129 Make-up section · Length 2 1/4"



5108 Quarter length = 1 3/4"



5109 2/16 length = 1 1/16"



5110 1/8 length = 7/16"



5111 Feeder track section, straight · Full length = 7" · 2 connecting cables



5146 Switching track section, straight · Half length = 3 1/2"



5105 Contact track section, straight · Full length = 7"



5114 Crossing · Length 7 1/8" = 30" · The crossing center conductors are electrically insulated from one another

Curved track sections 5200 for large parallel curve

Twelve 5200 track sections form a circle with an outside diameter of 36". Full length = 30"



5200



5206 Length = 24°17' · Matches the curve of the turnout 5202



5201 Half length = 15"



5205 Length = 5°43' · This section used with 5206 is equal to 5200



5213 Switching track section, curved · For parallel curve · Half length = 15" · Construction and operation as for 5146/5147



5208 Make-up section, straight · Length 5/16"



5210 Make-up section, straight · Length 5/16"



5211 Crossing · Frog angle 48 1/2° · Length 3 3/8" · The crossing center conductors are electrically insulated from one another



7299 Flush wood screws for mounting metal track · In packets of 200



Buffer stops

7190 Buffer stop · Die cast zinc buffer beam · 2 1/4" long

7191 Buffer stop with working signal light · Die cast zinc buffer beam · 2 1/4" long

Remote controlled uncoupling system

5113

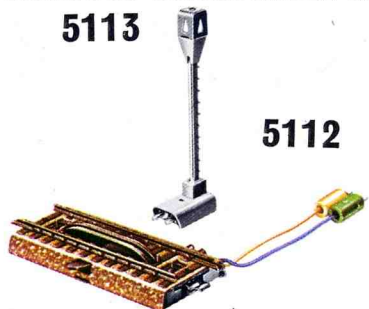

5112

5112 Uncoupling track section for releasing automatic couplings · The two ramps to the right and left of the contact studs are operated electronically by remote control and release the couplings when the button on the control panel or the manual switch lever is operated · 2 connecting cables · Length of track 3 1/2"

5113 Light standard for uncoupling track section · Die cast zinc · The signal on the standard lights up during the uncoupling · Height 3 3/8"

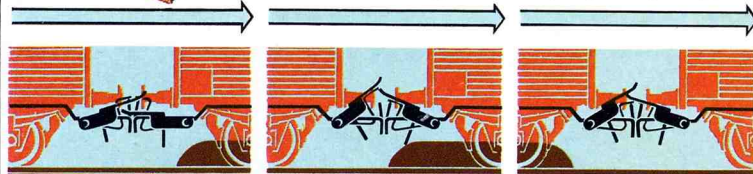

The coupling is released by raising the ramp.

The RELEX coupling is designed so that it remains "open" after uncou-

pling, which means that the coaches or cars can be pushed, or dropped off at any required point without the couplings closing again.

Rail operations only become realistic when it is not necessary to do the uncoupling of locomotives from trains or of cars from one another by hand any more. This can be done automatically using the uncoupling track section with its light standard whose signal lights up when the uncoupler is operated. When the coupling between locomotive and coach or between coach and coach is near the

uncoupler light, depressing the control panel button will open the coupling and the detached coach or section of train remains standing. Coaches with the advance uncoupler (RELEX) can then be pushed back again by the locomotive under remote control, without the coupling closing again.

At least four solenoid turnouts can be connected to one control panel (see page 60).

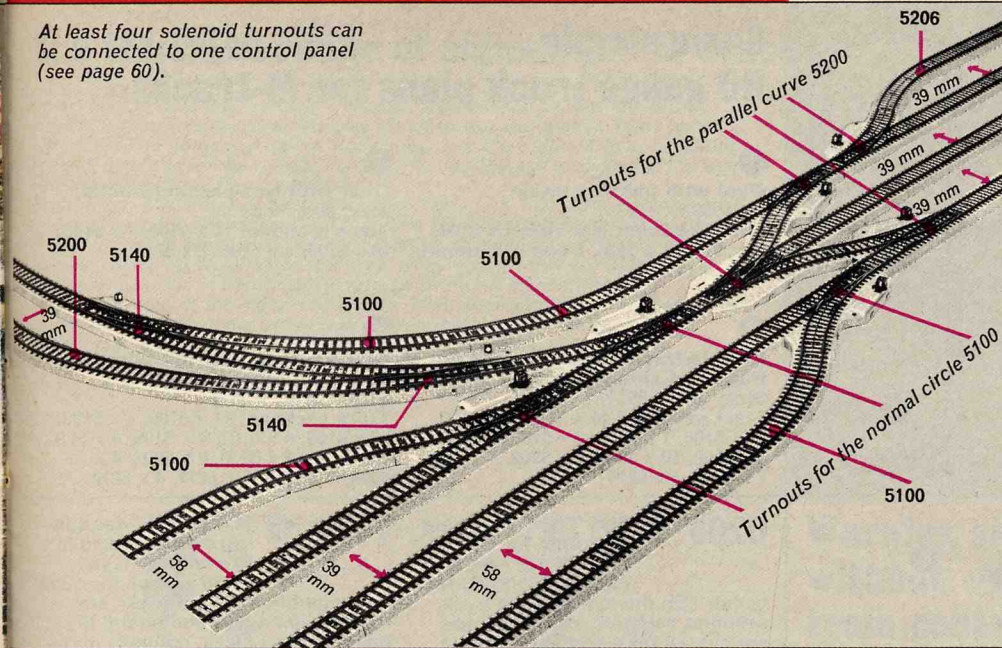

Fig. 1

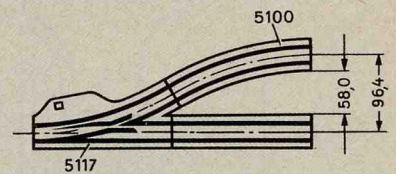

Fig. 2

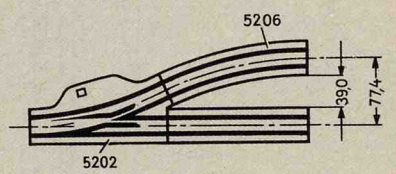
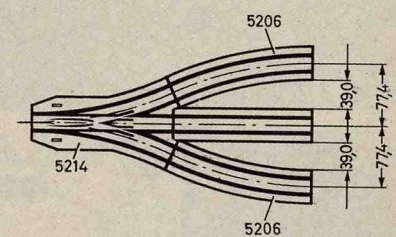

Fig. 3



MÄRKLIN M-turnouts and how to use them

When laying out sidings parallel to the main track using the 5117 and 5121 turnouts (Fig. 1), use curved track 5100 to form the reverse curve (distance between track centers $3\frac{1}{8}$ "). With the 5202 (Fig. 2) and 5214 (Fig. 3) turnouts on the other hand, use the track section 5206 to form the reverse curve. The turnout which is shorter by $\frac{1}{8}$ " in the curve, gives a reduced distance of $3\frac{1}{8}$ " between track centers.

The solenoid turnouts 5117, 5140 and 5202 and the double switch slips 5128 and 5207 are operated by double solenoids. When crossed in the reverse direction, the points of all the turnouts are opened up by the wheels of the vehicle. The turnouts return automatically to their initial setting. The working signal lights show the setting of the turnout. Further turnouts can be joined directly on to either end of the turnout section.

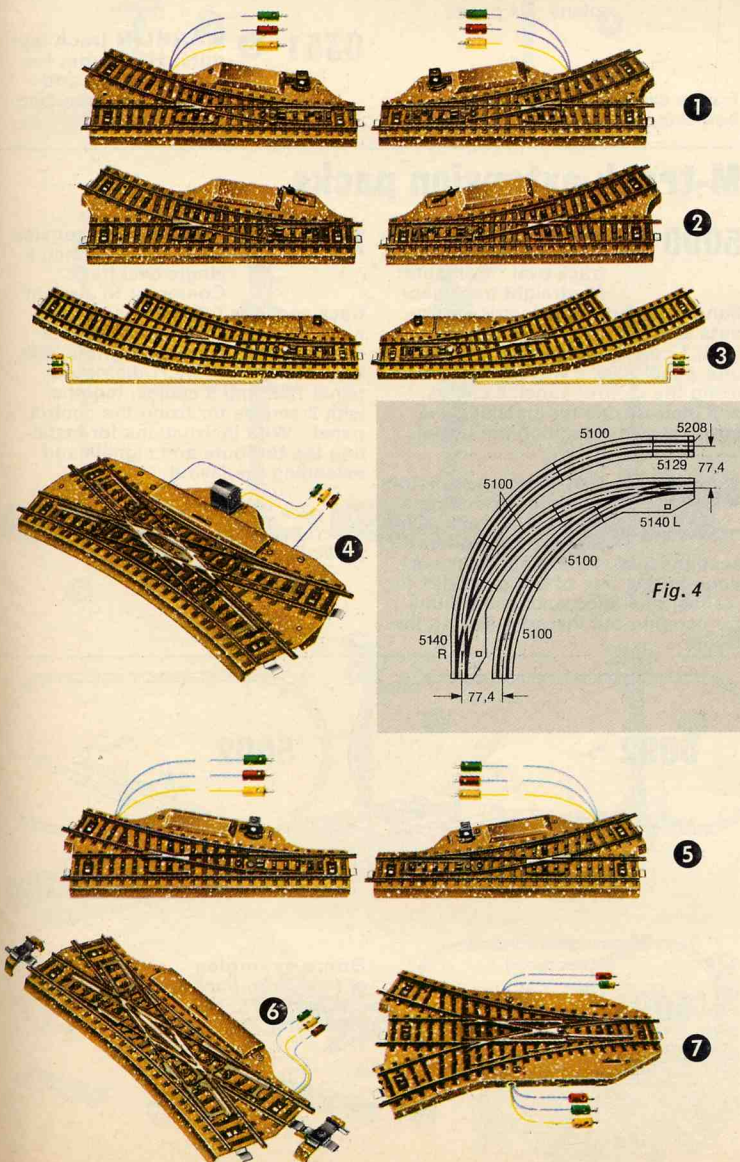

MÄRKLIN M-turnouts 5100 with sprung points

operated by double solenoids for remote control

5117 ① 5117 Pair of solenoid turnouts · Consisting of one right-hand and one left-hand turnout, both operated by double solenoids · Working signal lights · The track lengths are the same as track sections 5100 and 5106

5121 ② 5121 Pair of manually operated turnouts · Track dimensions as for 5117

5140 ③ 5140 Pair of solenoid curved turnouts · Consisting of a right-hand and a left-hand turnout, both operated by a double solenoid · Working signal lights · Length and curvature of the branch tracks as for track section 5100 · Length of the outer curve $10\frac{1}{2}$ "

If the curved turnouts are incorporated, the train when already in the curve can change from one track to the other. The narrow interval between the parallel curves of the track ($3\frac{1}{8}$ ") is maintained and space is saved for a longer overtaking section (Fig. 4).

5128 ④ 5128 Double slip switch · 30° crossing angle · Operated by double solenoid · Working electric signal lights which change to show the setting of the points (curve or crossing) · Hand lever for manual operation · Length of straight section $7\frac{1}{16}$ " , length of curve section $7\frac{1}{2}$ "

MÄRKLIN M-turnouts 5200 with sprung points

operated by double solenoid for remote control

5202 ⑤ 5202 Pair of solenoid turnouts · Consisting of one right-hand and one left-hand turnout, each with double solenoid · Working signal lights · The track lengths are as for track sections 5206 and 5106

5207 ⑥ 5207 Double slip switch · When used with the turnouts 5202 enables the track spacing of $3\frac{1}{8}$ " to be maintained · Operated by double solenoid · Hand switching lever on the drive case · Length of straight section $7\frac{1}{16}$ " · Two make-up sections 5208, each $\frac{5}{16}$ " long, are included

5214 ⑦ 5214 Symmetrical three-way turnout operated by 2 double solenoids · 2 hand levers for manual setting of the points · 5 connecting cables · Length of the straight track $7\frac{1}{16}$ " · Radius of the branch tracks $18\frac{1}{16}$ " , the same as for the outer circle track · When used with the 5206 track sections, the $3\frac{1}{8}$ " track center spacing can be maintained on both sides (see Fig. 3 above)

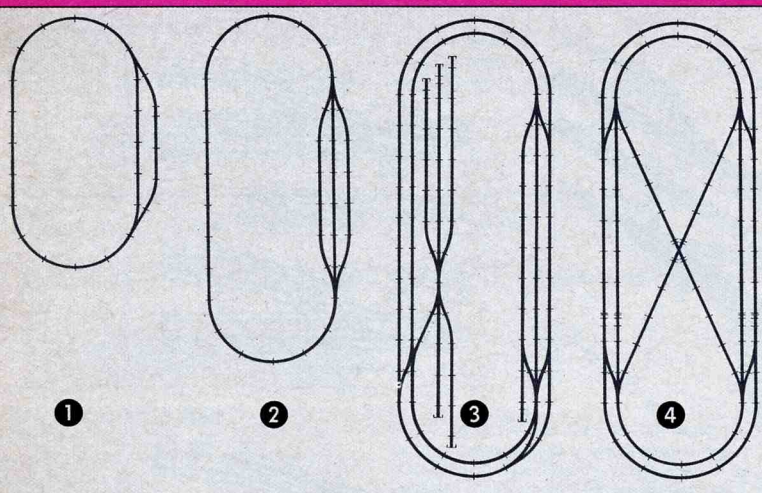

Some simple HO gauge track plans for M-tracks

- 1** **Oval with passing track**
Size: 58 1/4" x 33 1/2"
Track sections: 11 x 5100, 1 x 5103, 10 x 5106, 1 x 5108, 1 pair of turnouts 5117 or 5121
- 2** **Oval with two passing tracks**
Size: 80 1/4" x 33 1/2"
Track sections: 11 x 5100, 1 x 5103, 18 x 5106, 4 x 5206, 2 x 5214
- 3** **Double-track oval with passing track and sidings**
Size: 107" x 36 1/4"
Track sections: 11 x 5100, 1 x 5103, 61 x 5106, 1 x 5107, 3 x 5108, 1 x 5111, 1 x 5140, 10 x 5200, 2 x 5202, 4 x 5206, 1 x 5207, 4 x 5214
- 4** **Double track oval with double reversing loop**
Size: 106 1/4" x 36 1/4"
Track sections: 11 x 5100, 1 x 5103, 43 x 5106, 4 x 5107, 4 x 5108, 4 x 5110, 1 x 5111, 12 x 5200, 2 x 5202, 4 x 5208, 4 x 5210, 1 x 5211, 4 x 5214

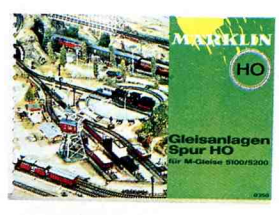
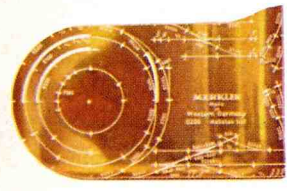

- 0206** **5** **0206 Track planning template for MÄRKLIN M-track sections (series 5100/5200) HO gauge** · On the template the track sections, turnouts, crossings, etc. are cut out on a scale of 1:10 and they can easily be transferred on to paper with a sharp pencil
- 7171** **6** **7171 Sound deadening strips** packed in 50's with 50 flush wood screws for quiet train operation · If the tracks are mounted on a plywood board, the trains as they move, naturally make some but not excessive, noise, to the rhythm of the wheels · If it is desired to dampen this noise down to about half, it is recommended that the tracks, turnouts and crossings should be laid on sound deadening strips · This makes no difference in the mounting of the catenary
- 0321** **7** **MÄRKLIN track layouts, HO gauge, for M-tracks 5100 and 5200** · Simple track plans · 24 pages
- 0351** **8** **MÄRKLIN track layouts, HO gauge, for M-tracks 5100 and 5200** · An outstanding guide · 86 pages

For an exact description of these booklets, see page 65

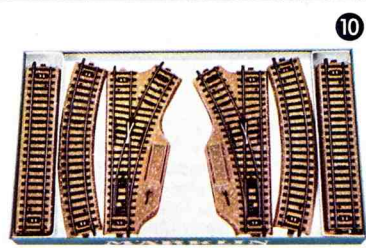
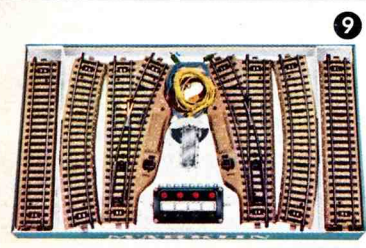

The track extension packs 5090, 5091 and 5092 can be used particularly for extending the track layouts in the

following Gift Sets: 2900-2914, 2960-2979, 3122, 3200 and 3203.

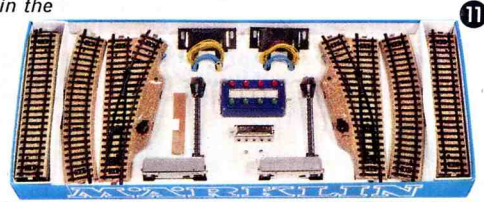

M-track extension packs

- 5090** **9** **5090 Track extension pack** for extending a track oval · Contents: 10 straight track sections 5106, 1 pair of electrical turnouts 5202, 2 curved track sections 5206, 1 control panel 7072, 1 distributor panel 7209, 2 wood screws for fixing the control panel, 2 cables and instructions for installing the turnouts and extending the layout
- 5092** **11** **5092 Track extension pack** for extending a single oval track · Contents: 13 straight track sections 5106, 1 pair of solenoid turnouts 5202, 2 curved track sections 5206, **2 home signals 7039**, 1 control panel 7072, 1 distributor panel 7209 and 5 cables, together with 2 screws for fixing the control panel · With instructions for installing the turnouts and signals and extending the layout
- 5091** **10** **5091 Track extension pack** for extending a single oval track · Contents: 2 curved track sections 5100, 10 straight track sections 5106, 1 pair of turnouts 5121 for manual operation and instructions for carrying out the extension to the layout

The pack 5092 contains signals which make the layout operation particularly interesting.

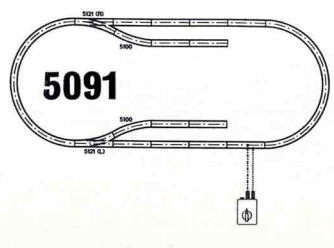
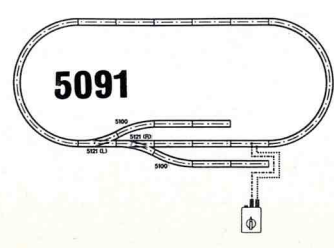
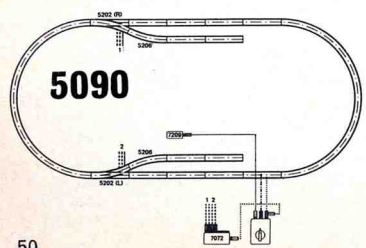
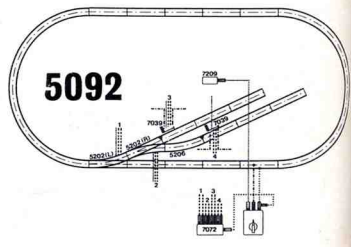
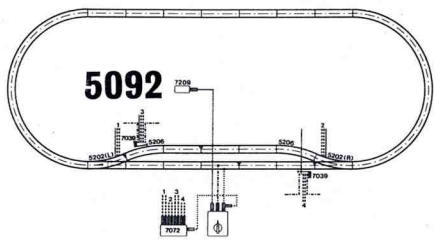
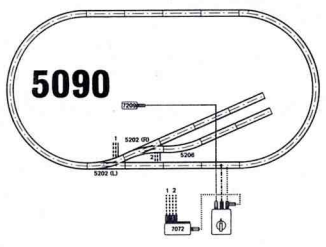
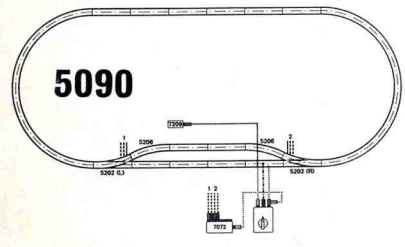

Some examples of how these track extension packs can be used to extend the Gift Sets 2900-2914, 2960-2979, 3122, 3200 and 3203.



The MÄRKLIN range of signals for M-tracks

There should be a few, suitably arranged, signals even on a small railway layout, and not just because the play of red, green and orange lights looks attractive. The home and siding signals regulate the traffic in that, by setting them at red or green by remote control, the starting and stopping of the trains can be controlled at the same time.

Even more: Switching or contact track sections only have to be incorporated and connected to the signals and then one train controls the other by means of the signals automatically, without it being possible for an "accident" to happen (block operations). In this way, while some trains are travelling as programmed, one is free to carry out e.g. shunting manoeuvres.

The installation of the signals is simple. Their base plates are clamped either to the right or left under straight or curved metal tracks and the cable connected as shown in the accompanying instructions. The signals are connected electrically to the control panels (7072, see page 60) in such a way that it can be seen from the position of the switch button

whether the signals are at "stop" or "go".

Anyone who wants his layout to be realistic, should install warning signals as well as the home signals described. They are mounted in the same way as the home signals and simply connected to them by a wire. With a control panel 7072, it is possible to operate, e.g. 4 home signals 7039 with warning signals, but also groups of signals and turnouts. The home and warning signals have rail current switches by means of which the current in the contact studs and in the catenary can be altered. The silver contacts in the switches enable them to cope with heavy loads. The connecting wires have color-coded plugs with side sockets allowing extra plugs to be inserted. In addition, sockets are incorporated into the signal bases for connection to the catenary and ground. Lighting is provided by small bulbs. Track insulators, a base plate and careful instructions are included in each pack.

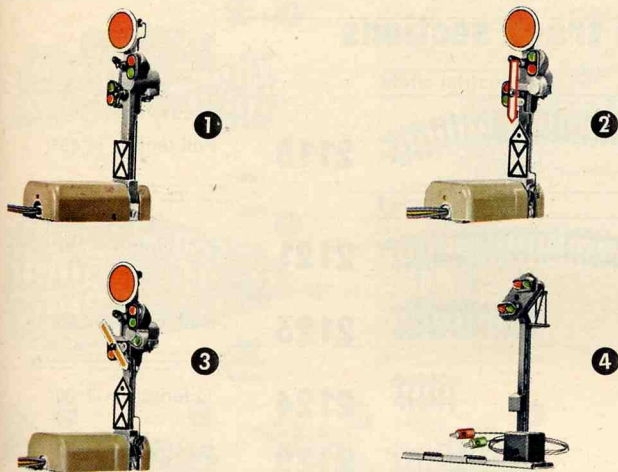

Warning signals without train control

7036 ① 7036 Warning signal with movable disc · Signal lights change from amber/amber to green/green. Double solenoid · Used with home signal 7039 · Width 1 1/8", length 2 5/8", height 2 7/8"

7037 ② 7037 Warning signal with extra movable arm · Disc fixed · Signal lights change from amber/amber to amber/amber/green · Double solenoid · Used with home signal 7040 · Width 1 1/8", length 2 5/8", height 2 7/8"

7038 ③ 7038 Warning signal with extra movable arm and movable disc · Signal lights change either as in 7036 or as in 7037 · 2 double solenoids · Used mostly with home signal 7041 · Width 1 1/8", length 2 5/8", height 2 7/8"

7187 ④ 7187 Color light warning signal · Used only in conjunction with home light signal 7188 · Signal lights change from green/green to amber/amber using four bulbs · Width 5/8", length 7/16", height 2 5/8"

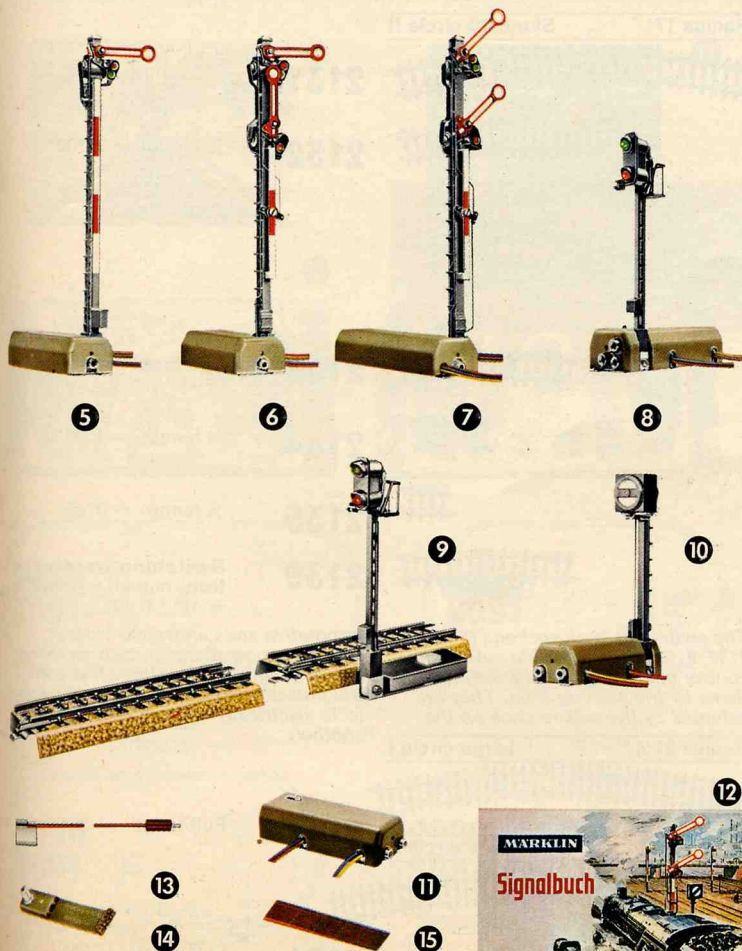

Signals with train control for catenary and rail conductors

7039 ⑤ 7039 Home signal with one semaphore arm · Signal light changes from red to green · Double solenoid · Width 1 1/8", length 2 3/4", height 5"

7040 ⑥ 7040 Home signal with two coupled semaphore arms · Signal lights change from red to green/amber · Double solenoid · Width 1 1/8", length 2 3/4", height 5"

7041 ⑦ 7041 Home signal with two independent semaphore arms · Signal lights change from red to green or red to green/amber · 3 solenoids · Width 1 1/8", length 3 7/8", height 5"

7188 ⑧ 7188 Color light home signal · Signal light changes from red to green · Double solenoid · Lighting by two bulbs · Additional manual switching lever · Pair of sockets for connecting to the warning signal 7187 · Width 1 1/8", length 2 3/4", height 3 1/2"

7339 ⑨ 7339 Color light home signal · Signal light changes from red to green by manual operation and at the same time controls the current to the section of metal track connected to the signal. Additional track section 3 1/2" long with continuous central conductor · Width 2 1/4", length 3 1/2", height 3 1/2"

7042 ⑩ 7042 Yard and siding signal · Mast with movable front and rear discs · Double solenoid · Width 1 1/8", length 2 3/4", height 2 3/4"

7045 ⑪ 7045 Universal remote control switch · It can be given various functions which it then carries out automatically and reliably, e.g. causing a moving train to switch station lighting on and off, overriding the control by signal for trains travelling in the opposite direction, and many more · It is all fully described in the installation instructions and our signal manual · The universal remote control switch is controlled from the control panel or by switching and contact track sections · Double solenoid · Width 1 1/8", length 2 3/4", height 7/16"

0341 ⑫ MÄRKLIN signal manual for M-tracks · For description see page 65

5004 ⑬ 5004 Connecting cable for center track conductor · Length 30"

5015 ⑭ 5015 Insulation marker for marking insulation points

5022 ⑮ 5022 Center track conductor insulation for insulating 5 joints



MÄRKLIN K-tracks 2100 (K = plastic)



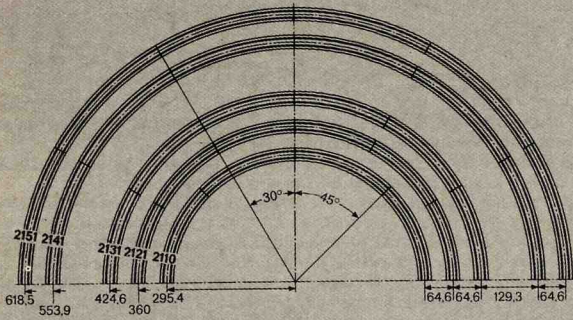

The MÄRKLIN K-track, 2100 series, uses the same stud contact system, the advantages of which were described on page 47. With these track sections the two rails are laid on plastic strip with ties. The contact studs project through from underneath the ties and ensure very reliable current pickup. The rails are connected by rail joiners, sprung connectors for the center conductor and snap couplings for the plastic tie strips. Flush wood screws 7599 (see page 53) are recommended for fastening the K-tracks to the base.



The five MÄRKLIN K-track circles:



- 1 industrial circle 2110 = 8 track sections
- 1 standard circle I 2121 = 12 track sections
- 1 standard circle II 2131 = 12 track sections
- 1 large circle I 2141 = 12 track sections
- 1 large circle II 2151 = 12 track sections

Straight track sections

-  **2100** Full length = 7"
-  **2101** Half length = 3½"
-  **2102** Quarter length = 1¾"
-  **2104** ¼ length = 7/8"

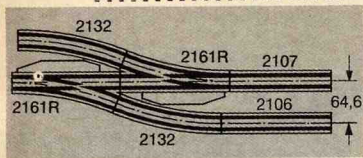
Straight make-up sections

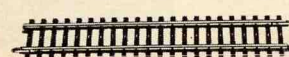
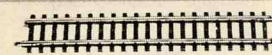

-  **2106** Length 6 ¾"
-  **2107** Length 6"
-  **2108** Length 1 ½"

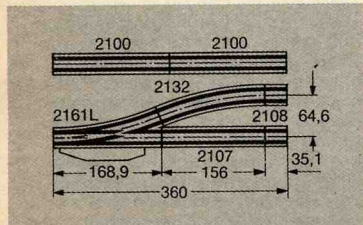

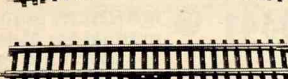

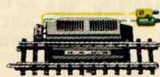

-  **2159** Crossing · Crossing angle 22°30' · Length of straight sections 6 ¾"
-  **2190** Feeder track section, straight · Full length = 7" · 2 cable terminals marked "0" and "B" for connecting the power cable

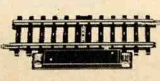
-  **2191** Adapter track section, straight · Full length = 7" · Makes it possible to connect track sections of the 5100 and 5200 series to the 2100 series

-  **2197** Uncoupler track section · Half length = 3 ½" · For releasing automatic couplings · The uncoupling ramp between the rails can be operated either manually by the hand switch lever, or from the control panel by means of solenoids incorporated

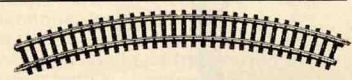
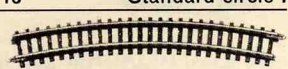
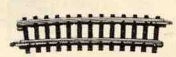
-  **2199** Switching track section, straight · Half length = 3 ½"

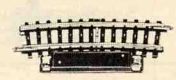
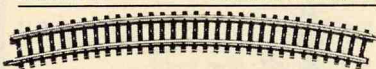
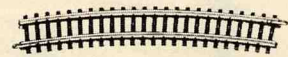
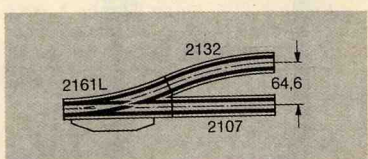
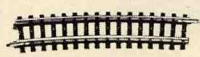
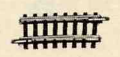
Curved track sections

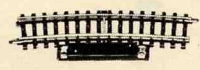
- Radius 12"** Industrial circle
 -  **2110** Full length = 45°
- Radius 15"** Standard circle I
 -  **2121** Full length = 30°
 -  **2123** Half length = 15°
 -  **2124** ¼ length = 7°30'
 -  **2129** Switching track section, curved · Half length = 15° R 15"
- Radius 17"** Standard circle II
 -  **2131** Full length = 30°
 -  **2132** ¼ length = 22°30'
- 
 -  **2133** Half length = 15°
 -  **2134** ¼ length = 7°30'
 -  **2135** ¼ length = 3°45'
 -  **2139** Switching track section, curved · ½ length = 15° · R 17"

The switching track sections (2129, 2139, 2199) make possible automatic control of all magnetically operated items by the passing train. They are actuated by the pickup shoe on the

locomotive and can trigger various switching operations in each direction independently of the other. The control pulses are picked up from two contacts electrically isolated from one another.

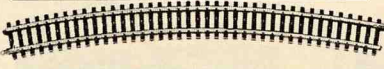
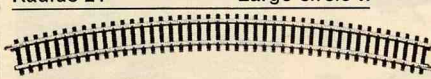
- Radius 21 ½"** Large circle I
 -  **2141** Full length = 30°
- Radius 24"** Large circle II
 -  **2151** Full length = 30°

K-turnouts K-track extension packs

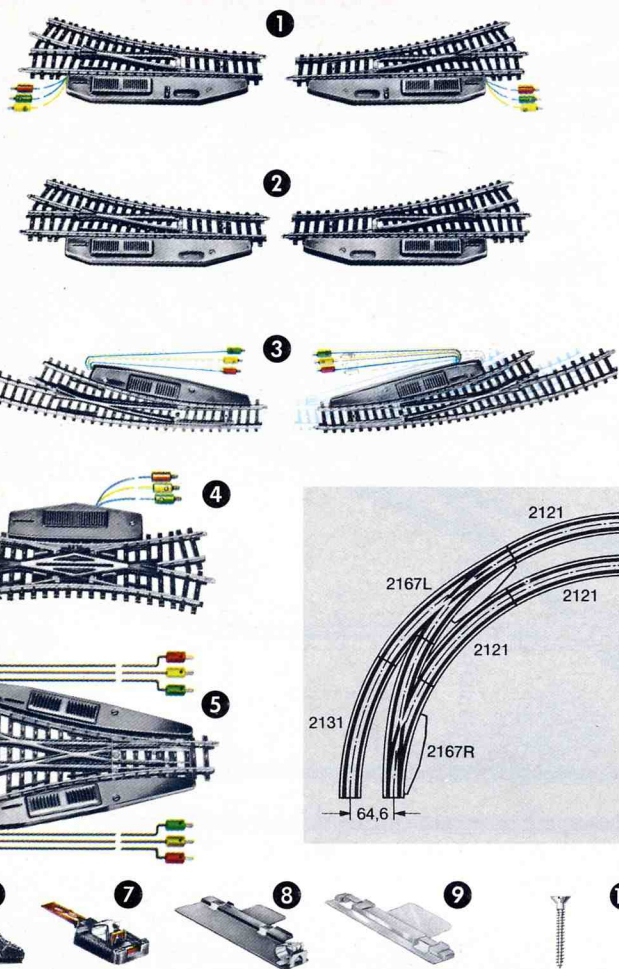

MÄRKLIN K-turnouts 2100 with sprung points

- 2161** ① **2161 Pair of solenoid turnouts** · Consisting of one right-hand and one left-hand turnout, each operated by double solenoid · Working signal lights · Frog angle 22°30' · Radius of branch track 17" · Length of straight section 6⁷/₁₆"
- 2170** ⑤ **2170 Symmetrical three-way turnout** operated by 2 double solenoids · 2 hand lever for manual setting of the two pairs of points · Length of the straight track section 6⁷/₁₆" · Frog angle 22°30' · Radius of the branch tracks 17"
- 2164** ② **2164 Pair of manually operated turnouts** · Consisting of one right-hand and one left-hand turnout · Frog angle 22°30' · Radius of branch track 17" · Length of straight track 6⁷/₁₆" · Operated by hand lever
- 7391** ⑥ **7391 Buffer stop** of riveted steel construction · Snaps into the rails · Length 1¹/₂" · Wood screw for fixing supplied
- 7500** ⑦ **7500 Ground connection** with terminal for connecting the ground wire to track of series 2100
- 2167** ③ **2167 Pair of solenoid curved turnouts** · Consisting of one right-hand and one left-hand inside turnout operated by double solenoid · Length and curvature of the branch track as for track section 2121 · Length of the outside track section 9¹/₂"
- 7504** ⑧ **7504 Connection for center conductor** with terminal · Is pushed, at the rail joint, on to the contact strip of the track sections of series 2100
- 2160** ④ **2160 Double slip switch** · Crossing angle 22°30' · Radius 17" · Inside points operated by double solenoid actuated remotely · Additionally, hand lever for manual operation · Length of the straight track section 6⁷/₁₆"
- 7522** ⑨ **7522 Insulation for center conductor** · Is inserted at the rail joint, between the contact strips of the track sections of series 2100 to provide a break in the circuit
- 7599** ⑩ **7599 Flush wood screws** for fixing plastic tracks · Packed in 200's



- 0371** ⑪ **MÄRKLIN track layouts, H0 gauge, for K-tracks 2100** · Outstanding guide · 52 pages
- 0379** ⑫ **MÄRKLIN track layouts, H0 gauge, for K-tracks 2100** · Simple track plans · 20 pages

These booklets are described on page 65

K-track extension packs

- 2090** ⑬ **2090 Track extension pack** for extending an oval track · Contents: 8 straight track sections 2100, 2 straight track sections 2107, 4 straight make-up sections 2108, 2 curved track sections 2132, 1 pair solenoid turnouts 2161, 1 control panel 7072, 1 distributor panel 7209, 2 wood screws for fixing the control panel, 2 cables and instructions for installing the turnouts and extending the layout
- 2091** ⑭ **2091 Track extension pack** for extending an oval track · Contents: 8 straight track sections 2100, 2 straight track sections 2107, 4 straight make-up sections 2108, 2 curved track sections 2132, 1 pair of turnouts for manual operation 2164, instruction for extending the layout

Some examples of applications of 2090 and 2091

With the track extension pack 2091, the manually operated turnout 2164 takes the place of the solenoid turnout 2161 shown in the track plan. The control panel 7072 and distributor panel 7209 are omitted in addition.

The track extension packs 2090 and 2091 can be used for extending the track layouts in Gift Sets 2800-2818 and 3183.

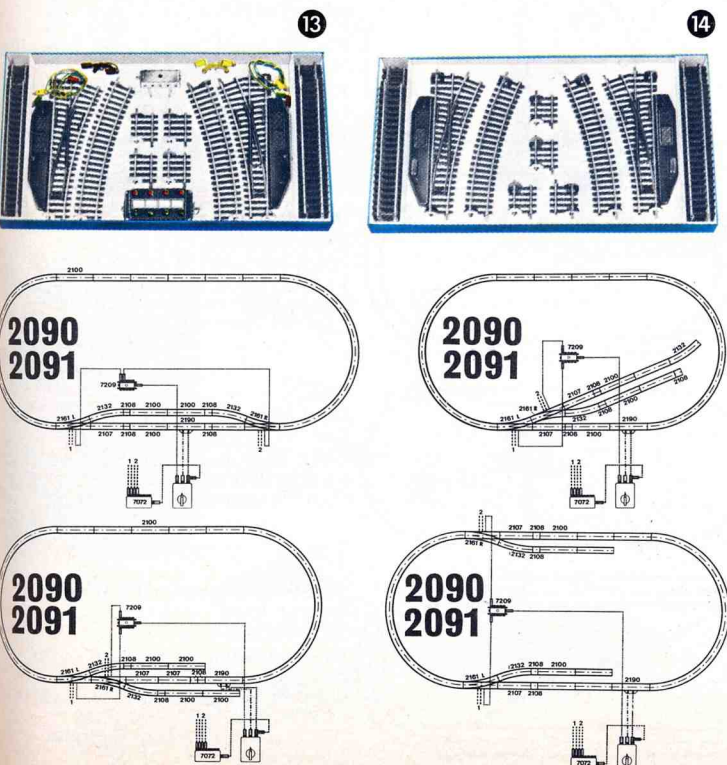



Track plan for a MÄRKLIN HO layout with K tracks

86 1/2" x 59"

The track plan is taken from our publication 0371 (pages 40 and 41, annex 1), which also contains other interesting suggestions.

Track plan for MÄRKLIN HO layout on the pages 33, 35 and 47.

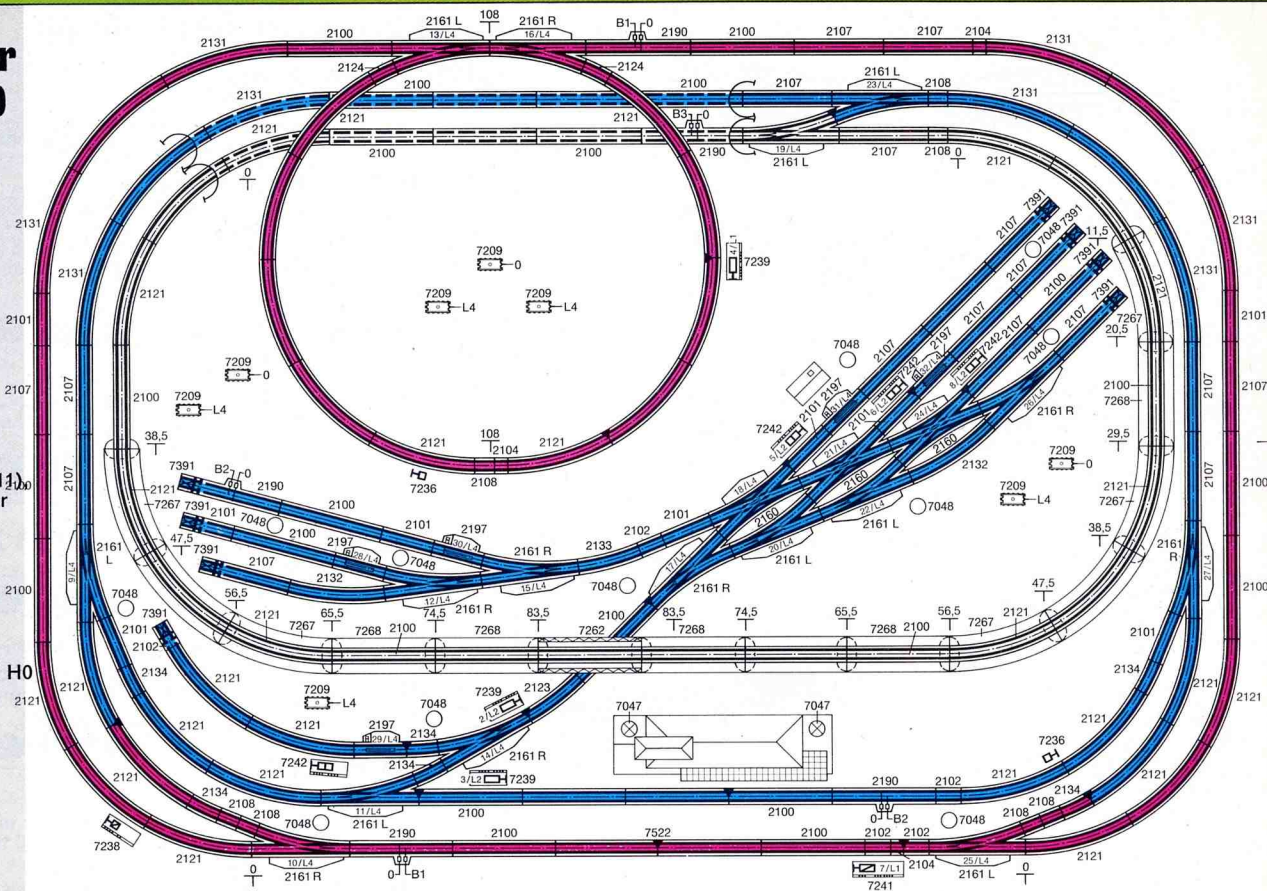

Parts list

For building this model railroad layout, the following items were used:

- | | | |
|---------|---------|---------|
| 33-2100 | 12-2131 | 2-7047 |
| 9-2101 | 2-2132 | 11-7048 |
| 5-2102 | 1-2133 | 9-7072 |
| 3-2104 | 6-2134 | 8-7209 |
| 18-2107 | 3-2160 | 2-7236 |
| 7-2108 | 8-2161 | 1-7238 |
| 38-2121 | 5-2190 | 3-7239 |
| 1-2123 | 5-2197 | 1-7241 |
| 2-2124 | | 4-7242 |

- | | | |
|---------|---------|---------|
| 15-7250 | 18-7000 | 4-7114 |
| 8-7251 | 7-7101 | 73-7115 |
| 32-7252 | 3-7102 | 90-7131 |
| 18-7253 | 3-7103 | 76-7132 |
| 1-7262 | 3-7105 | 40-7133 |
| 7-7267 | 32-7111 | 4-7134 |
| 6-7268 | 44-7112 | 85-7135 |
| 8-7391 | 38-7113 | |

- 1 Lighting transformer 50 VA
3 Transformers 30 VA

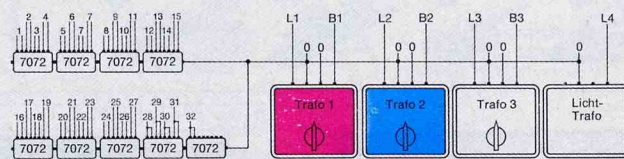

Symbol code

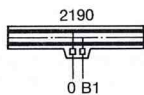

0 B1
Locomotive current feeder track for point contact conductor. Red cable from terminal B, brown cable from terminal O to sockets of the same color on transformer 1.



3
Blue cable with green plug in green socket; blue cable with red plug in red socket of the pair of sockets, e.g. those marked "3", on the control panel (7072).



L1
Yellow cable yellow lighting current socket L on transformer 1 or the terminal strip L1 connected to it.



Circuit isolation with isolating section 7522.

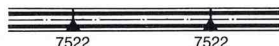

Isolating section for halting train in conjunction with signals. The length of the section must be suited to the speed and the stopping distance of the trains.

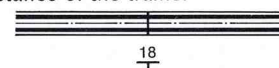

Height of pier or track support in mm.

0207 0207 Track planning template for MÄRKLIN K-tracks (series 2100), HO gauge. Track sections, turnouts, crossings, etc. are cut out on the template to a scale of 1:10 and can easily be transferred on to paper with a sharp pencil

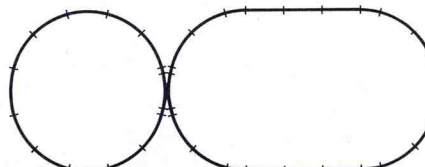
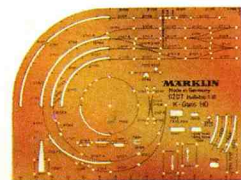

Some simple HO gauge track plans for K-tracks

Simple track layout with crossing

Size: 82 1/2" x 33"
Track sections: 5 x 2100, 18 x 2121, 4 x 2123, 2 x 2131, 4 x 2135, 1 x 2190, 1 crossing 2159 or 2160

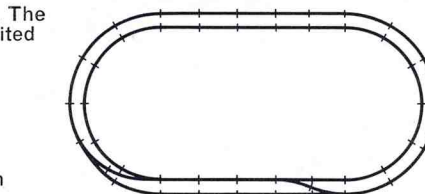

Double track oval

Size: 72" x 37 1/2"
Track sections: 11 x 2100, 2 x 2106, 4 x 2107, 12 x 2121, 10 x 2131, 1 x 2190, 2 right-hand turnouts 2161 or 2164, 1 pair of turnouts 2167

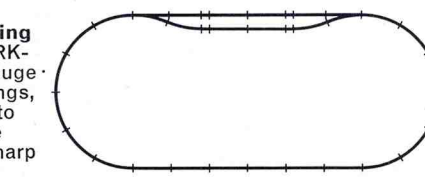

Oval with passing siding

Size: 74 3/4" x 32"
Track sections: 9 x 2100, 2 x 2107, 4 x 2108, 12 x 2121, 2 x 2132, 1 x 2190, 1 pair of turnouts 2161 or 2164

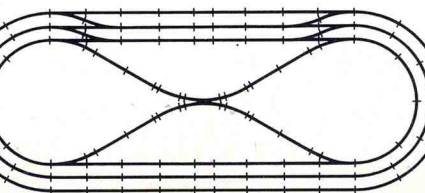

Three-track oval with double reverse loop

Size: 92" x 37 1/2"
Track sections: 11 x 2100, 6 x 2101, 4 x 2104, 22 x 2106, 10 x 2107, 8 x 2110, 12 x 2121, 12 x 2131, 4 x 2133, 4 x 2134, 4 x 2135, 1 x 2190, 1 crossing 2159 or 2160, 6 pairs of turnouts 2161 or 2164

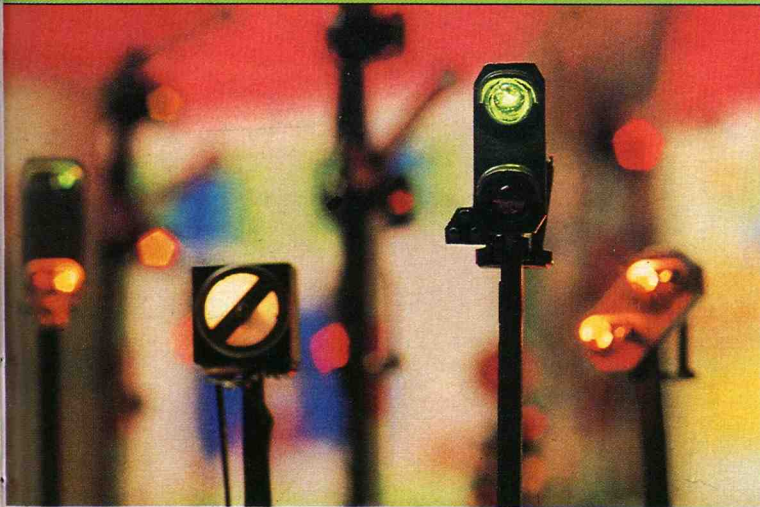

MÄRKLIN signals 7200 for K+M-track

The home light signals and siding signals of the series 7200 are equipped with switches for the power to the locomotives, with separate control for the catenary system and the center contacts on the track. The masts of these signals, or the light-holder housing of the siding signal 7242, can be set up individually and separated from the signal actuation. For fixing the masts, the bracket 7230 is required. Base plates 7531, 7532 and 7533 are used in connecting to the track sections of series 2100 to ensure grounding of the tracks.

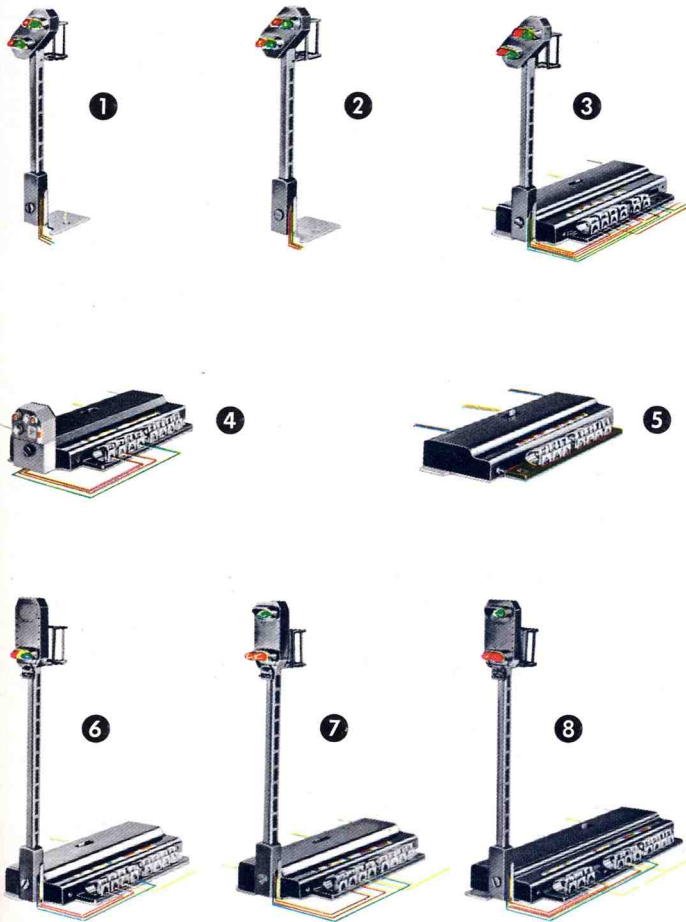

7236 ① 7236 Warning light signal · Signal lights change from amber/amber (caution) to green/green (proceed) using 4 bulbs · Only for connection to the home light signal 7239 · Used with fixing bracket 7230 · Width $\frac{3}{8}$ " length $1\frac{1}{8}$ ", height $2\frac{1}{2}$ "

7237 ② 7237 Warning light signal · Signal lights change from amber/amber (caution) to amber/green (proceed with caution) using 4 bulbs · Only for connection to the home light signal 7240 · To be used with fixing bracket 7230 · Width $\frac{3}{8}$ ", length $1\frac{1}{8}$ ", height $2\frac{1}{2}$ "

7238 ③ 7238 Warning light signal · Signal lights change from amber/amber (caution) to green/green (proceed) or amber/green (proceed with caution), using 4 bulbs · Electromagnetic double solenoid operation for the green/amber setting · To be used with home light signal 7241 · Width $1\frac{1}{8}$ ", length $2\frac{3}{4}$ ", height $2\frac{1}{2}$ "

7242 ④ 7242 Siding signal, dwarf version · Signal lights change from red/red (stop) to white/white (proceed with extreme caution) and the traction current is controlled by double solenoid operation · Two light bulbs provide the signals · Additionally, a lever for manual operation · Width $1\frac{1}{8}$ ", length $2\frac{3}{4}$ ", height $\frac{3}{4}$ "

7245 ⑤ 7245 Universal remote control switch with 2 single-pole switches and a change-over switch for various circuits · Operated by double solenoid · Can be set by means of switching track sections, the control panel or an extra, manually operated, lever · The instructions provided explain the various applications · Width $1\frac{1}{8}$ ", length $2\frac{3}{4}$ ", height $\frac{3}{8}$ "

7239 ⑥ 7239 Light home signal · Signal light changes from red (stop) to green (proceed) with simultaneous control of the traction current by double solenoid · 2 bulbs · Additionally, a manually operated switch · Width $1\frac{1}{8}$ ", length $2\frac{3}{4}$ ", height $3\frac{1}{2}$ "

7240 ⑦ 7240 Light home signal · Signal lights change from red (stop) to green/amber (proceed with caution), with control of the traction current by operation of a double solenoid · 3 bulbs · Additionally, a manually operated lever · Width $1\frac{1}{8}$ ", length $2\frac{3}{4}$ ", height $3\frac{1}{2}$ "

7241 ⑧ 7241 Light home signal · Signal lights change from red (stop) to green (proceed) or green/amber (proceed with caution), with control of the traction current by double solenoid with a third solenoid in addition for the green/amber setting · 3 bulbs · 2 additional manually operated levers · Width $1\frac{1}{8}$ ", length $3\frac{3}{4}$ ", height $3\frac{1}{2}$ "

Insulators for center track conductors, terminals for center track conductors and instructions are included with the home signals 7239, 7240 and 7241.

7230 ⑨ 7230 Fixing bracket · Is required with the mast of light signals 7238, 7239, 7240, 7241 or the siding signal 7242 if set up separated from the solenoid drive

7531 ⑩ 7531 Mounting plate for connecting the warning light signals 7236 and 7237 to track sections of series 2100

7532 ⑪ 7532 Mounting plate for connecting the light signals 7238, 7239, 7240 and 7242 to track sections of series 2100

7533 ⑫ 7533 Mounting plate for connecting the light home signal 7241 to track sections of series 2100

7539 ⑬ 7539 Light home signal · Signal light changes from red (stop) to green (proceed) by manual operation with simultaneous control of the traction current in the center track conductor of the track section which is permanently connected. Additional track section $3\frac{1}{2}$ " long with continuous center conductor · Width $2\frac{1}{8}$ ", length $3\frac{1}{2}$ ", height $3\frac{1}{2}$ "

0361 ⑭ MÄRKLIN signal manual for K-tracks · Description on page 65

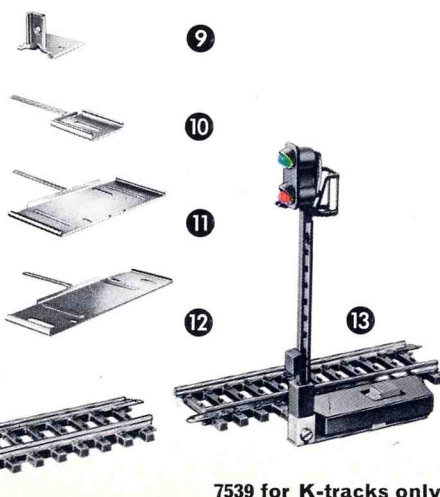
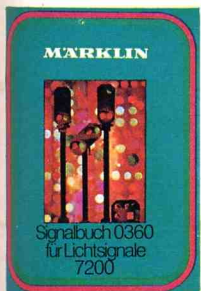

7539 for K-tracks only

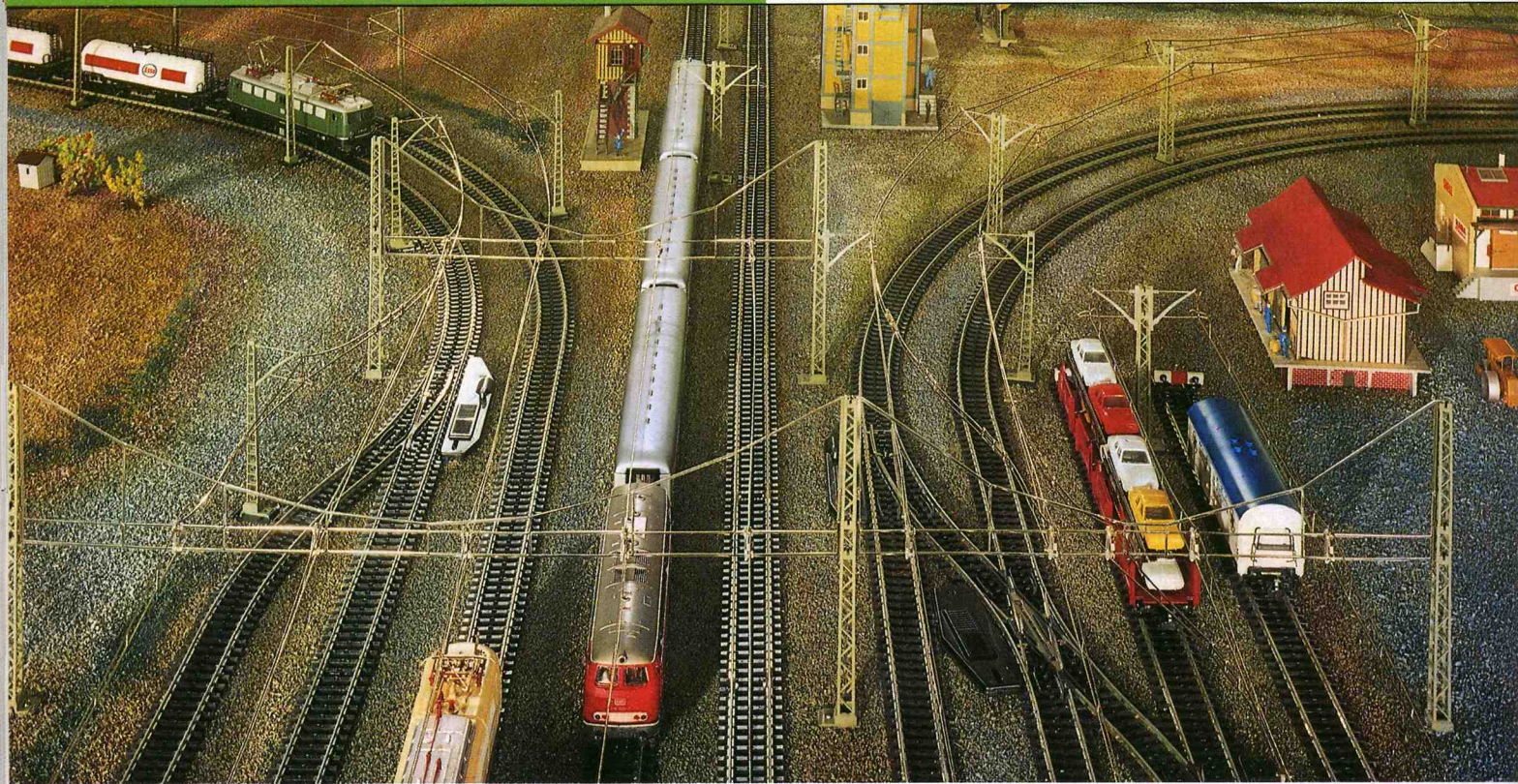

The electric locomotives can pick up their current from the overhead contact wire with the same reliability as from the stud contacts. All that has to be done is to switch over a small lever on the locomotive. With the MÄRKLIN system it makes no difference in which direction the locomotive is placed on the track. It is advisable to connect the catenary system to a separate transformer. Two trains can then run independently of one another on the same track using the catenary system and the stud contacts.

MÄRKLIN catenary system for M-track 5100/5200

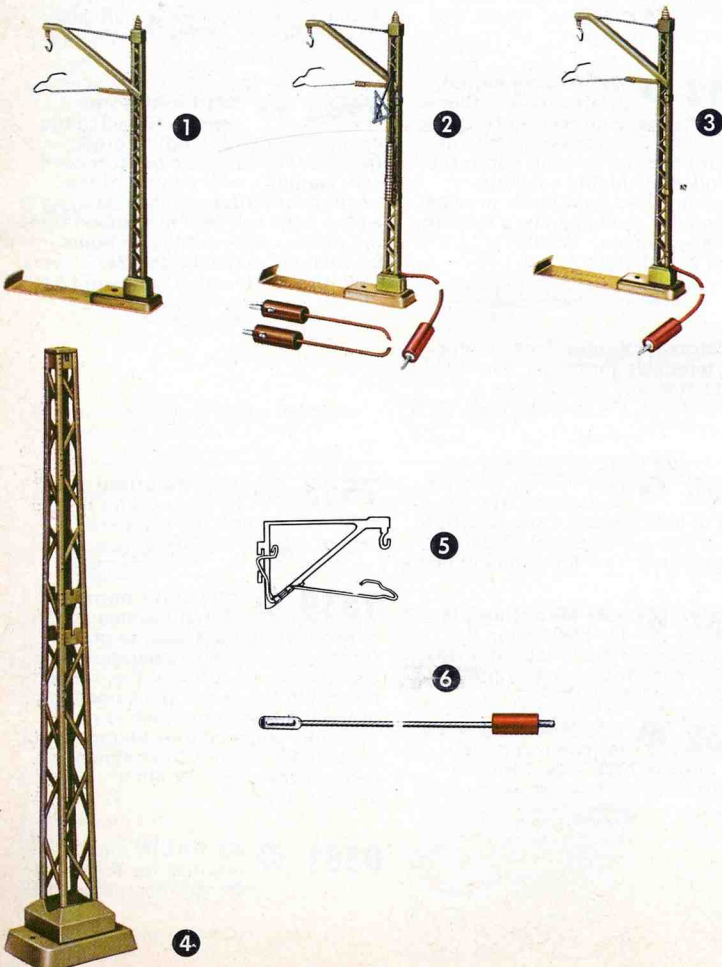

- 7009** ① **7009 Catenary mast** · Basic unit · Height 4³/₈"
- 7010** ② **7010 Feeder mast** for supplying current, with 2 cables and instructions for using the catenary system · Height 4³/₈"
- 7011** **7011 Bridge mast** with mounting bracket · For metal bridges only · Height 4³/₈"
- 7012** ③ **7012 Feeder mast** for signals, with 1 cable · Height 4³/₈"
- 7021** ④ **7021 Tower mast**, plastic · Base 1" x 1 1/4" · Height 7 1/2" · For tower mast with lights, see page 63
- 7025** ⑤ **7025 Cantilever support arm** · A single track passing by the tower mast can be connected to the overhead line by means of the cantilever support arm 7025
- 7003** ⑥ **7003 Cantilever system feeder cable** for connection to signals when tower masts are used, and for supplying current to any point · Length 24"
- 7005** **7005 Catenary set** for train control for signals of the 7000 series which are not mounted on tower masts · Consisting of 2 feeder masts 7012, 2 insulator pieces 7022 and 2 contact wires 7014

The overhead contact wires with their tensioning and cross span connectors are designed exactly like the real thing. That is why the MÄRKLIN catenary system appears so realistic both on single tracks and above all where spanning station tracks. The contact wire sections are for use both with M-tracks and with K-tracks. The spring contact wire holders on the mast ensure reliable contact with the contact wires. The ingenious snap-plug connectors allow most contact wires, e.g. 7013 and 7023, always to be pushed through to the required length. The contact

wires are flexible and can be adapted to any curve, without the use of any auxiliary equipment. The longest contact wire section 7019 is intended for long straight runs. Using the tower masts 7021 and 7521 and the cross spans 7016, any width of tracks can be spanned. 4 tracks need one cross span and 2 tower masts, and each extra 4 tracks a further cross span and a tower mast. For single tracks passing by a tower and not between two towers, the overhead contact wire can be mounted on the cantilever arms 7025 and 7525.

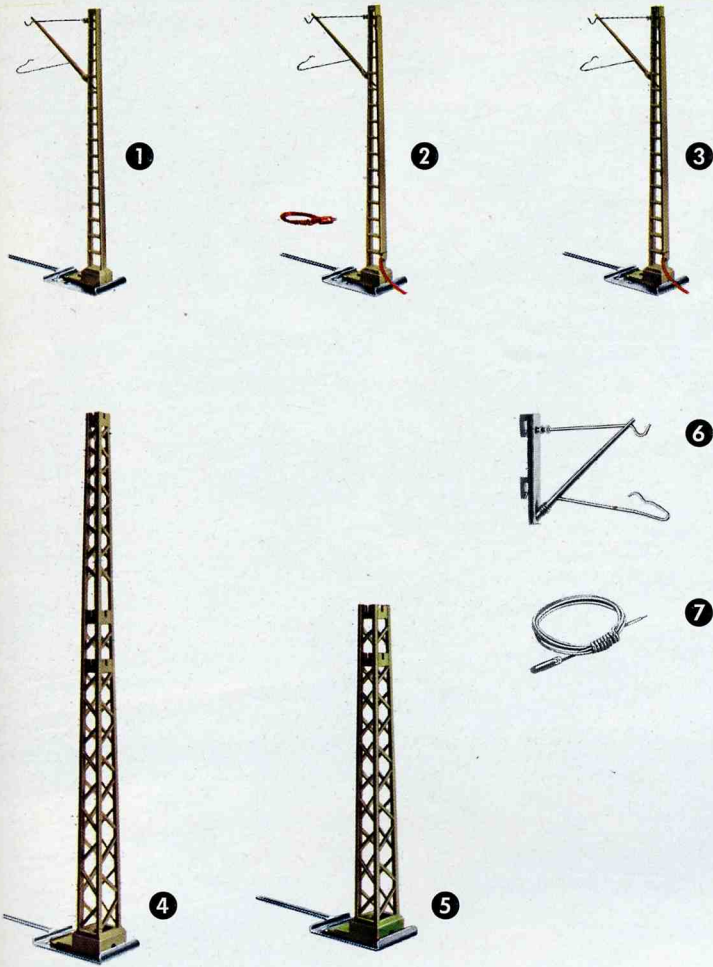

MÄRKLIN catenary system for K-track 2100

7509 ① 7509 Catenary mast · Basic mast for constructing a catenary system with the track sections of the 2100 series · Height 3⁷/₈" · With base plate for fastening to the track

7510 ② 7510 Feeder mast with red cable with plug connected to the mast · Brown cable with plug · Instructions for building the catenary system are included · Height 3⁷/₈" · With base plate for fastening to the 2100 series track

7512 ③ 7512 Feeder mast with red cable for connecting the catenary system to the home signals · Height 3⁷/₈" · With base plate for fastening to the series 2100 tracks

7521 ④ 7521 Tower mast with recesses to support the cross connections to the catenary system · Base 1/2" x 3/4" · Height 6" · With base plate for fastening to the series 2100 tracks

7524 ⑤ 7524 Lattice mast with recesses to support the cantilever arm 7525 · Height 3 3/4" · With base plate for fastening to the series 2100 tracks

7525 ⑥ 7525 Cantilever support arm for suspending single or double catenary wires, in conjunction with tower mast 7521 or lattice mast 7524

7503 ⑦ 7503 Catenary system connecting cable · For use in connecting the signals with the catenary system when tower masts are used and for feeding the catenary system current to any point · Grey cable · Length 22"

7505 7505 Catenary set for train control for home light signals of the 7200 series, which are not mounted on tower masts · Consisting of 2 feeder masts 7512, 2 insulator pieces 7022 and 2 contact wires 7014 · For use with track sections of the 2100 series

MÄRKLIN catenary system for K+M track

7511 ⑧ 7511 Bridge mast · For attaching to the side of plastic bridges and ramps · Height 3⁷/₈"

7004 7004 Fastening kit · Consisting of 5 bolts, 5 nuts and 5 washers · It is used only in exceptional cases, where it is not possible to make a reliable joint in contact wire sections by the usual method

7006 ⑨ 7006 Contact wire insulator · Insulating a section of the contact wire from cross spans · One required for each track and cross span · 5/8" x 1/4"

7013 ⑩ 7013 Contact wire section for plug connection, specially for turnouts · Length 9 1/2"

7014 ⑪ 7014 Contact wire section · Female portion (for plug connection) · Length 4 1/2"

7015 ⑫ 7015 Contact wire section · Male portion (for plug connection) · Length 4 1/2"

7016 ⑬ 7016 Cross span · Nickel plated · For hooking into tower masts · Spans about 4 tracks · Span 15 1/2"

7017 ⑭ 7017 Cross span · Nickel plated · For hooking into tower masts · Spans about 3 tracks · Span 11"

7018 ⑮ 7018 Contact wire section for straight and curved sections · Length 10 1/2"

7019 ⑯ 7019 Contact wire section for straight track only · Length 14 1/2"

7020 ⑰ 7020 Contact wire tensioner for fixing to track and tower masts

7022 ⑱ 7022 Insulator section · Male portion (for plug connection) for interrupting the contact wire current · Length 4 1/2"

7023 ⑲ 7023 Make-up section for plug connection · Length 4"

7277 ⑳ 7277 Crossing section for 2159, 2160, 5114, 5128, 5207 and 5211

7278 ㉑ 7278 Contact wire section, specially for use with track sections 2121 · Length 9 1/4"



K + M



1

7269 for **M** only

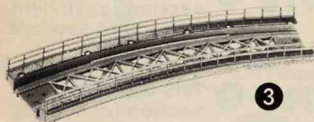

3

K + M

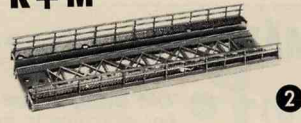

2

7569 for **K** only

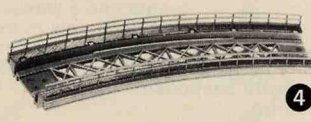

4

K + M

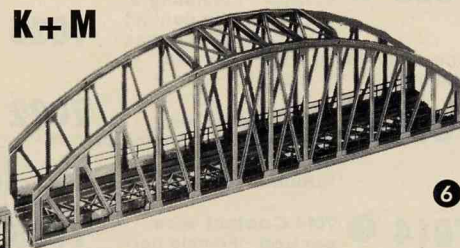

6

K + M



5



7



8



9



10



11

MÄRKLIN bridges in plastic for K + M tracks

With these MÄRKLIN bridge parts any size or combination of bridges and ramps can be built. The pier constructional elements 7252 and 7253, which fit together like building blocks, enable piers of any height to be built up in steps of $\frac{1}{8}$ ". When using the base plate 7251 in conjunction with the base plate 7250 it is even possible to raise the height by steps of $\frac{1}{8}$ " at a time. For fixing the pier sections on the base plate and fixing the sections together the use of buttonhead screws is recommended.

7267 1 7267 Curved ramp section · Grey · Radius of curvature 15" · For use with plastic or metal tracks · 3 clamps for fixing the K-track · Length and radius as for track sections 2121 and 5100

7268 2 7268 Straight ramp section · Grey · For use with plastic or metal tracks · 3 clamps for fixing the K-tracks · Length 7"

7269 3 7269 Curved ramp section · Grey · Radius of curvature 18" · For metal tracks 5200 only · Angle subtended 30°

7569 4 7569 Curved ramp section · Grey · Radius of curvature 17" · For plastic tracks only · 3 clamps for fixing the track sections · Length and radius as for track section 2131

7234 11 7234 Base plate · For fastening signal masts of the signal series 7200 to bridges

7262 5 7262 Truss bridge · Grey · Can be used on its own, or with arch bridge 7263 · For use with plastic or metal tracks · 3 clamps for fixing K-tracks and instructions for bridge building · Height $1\frac{1}{8}$ " · Length 7"

7263 6 7263 Arch bridge · Grey · For use with plastic or metal tracks · 6 clamps for fixing K-tracks and instructions for bridge building · Height of arch $4\frac{1}{2}$ " · Length 14"

7250 7 7250 Base plate · $\frac{1}{16}$ " high · Light brown · Can be used as foundation

7251 8 7251 Base plate · $\frac{1}{8}$ " high · Light brown · To be used only in conjunction with 7250

7252 9 7252 Pier · $\frac{1}{8}$ " high · Grey · Suitable for building ramps with $\frac{1}{8}$ " rise from one pier to the next

7253 10 7253 Pier · $\frac{1}{4}$ " high · Grey

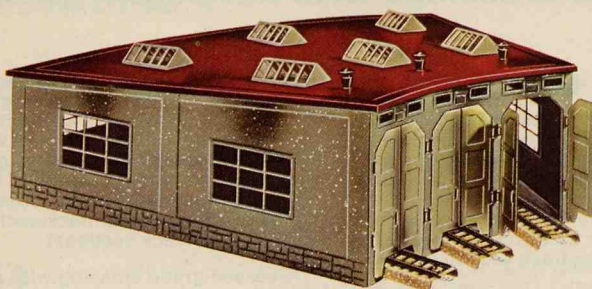

2

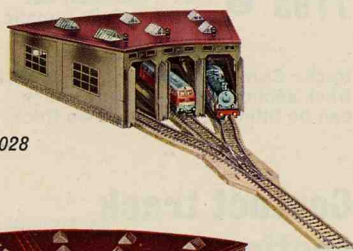

Suggested combination for engine shed 7028 with three-way turnout 5214

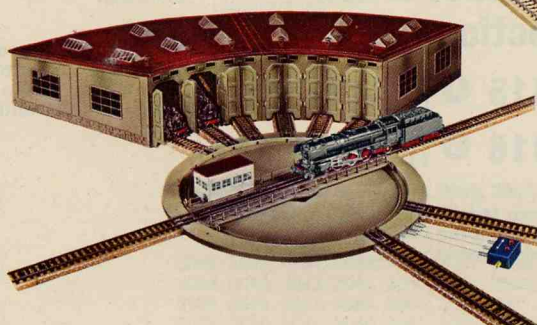

This illustration shows two roundhouses used with the turntable to give a realistic reproduction of the original.

Remote controlled turntable Locomotive roundhouse

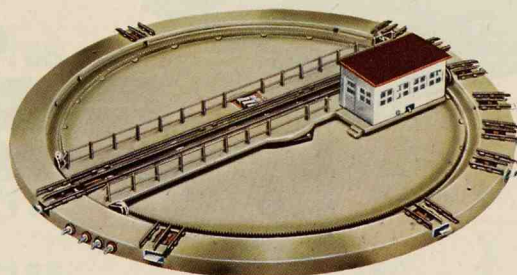

1



A turntable and roundhouse help to complete your model railroad. The turntable is used to enable locomotives to be turned on the spot so that they have the smokestack in front in the direction of travel. Most steam locomotives have higher authorised speeds when travelling forwards and not backwards. In addition the turntable is used to distribute the locomotives to the 3 or 6 tracks in the roundhouse. The current is cut off in all tracks not in contact with the turntable track.

7186 1 7186 Turntable set · Consisting of turntable, 14" outside diameter, turning in either direction by remote control, change-over switch and cable · Current is automatically cut off from all tracks not in contact with the turntable track

Adapter track section 2191 (see page 52) enables K-track 2100 to be connected to the turntable 7186.

7028 2 7028 Locomotive roundhouse with 3 automatically closing doors for 3 tracks (track sections not included) · Size 18 1/4" x 14 3/8" · Height 5 1/4"

Remote controlled slewing crane

Whoever wants to load and unload his freight trains properly, needs this crane. The lifting magnet will of course lift only iron, but other things besides "scrap iron" and "pig iron" can still be loaded. A couple of small screws, screwed inconspicuously into wood, and everyone is surprised to see the magnet lift a wooden crate or planking out of a truck on to a freight car. A slewing crane not only extends the interesting variations in the operation of a model railroad system since all the operations can be remotely controlled, but it adds realism to the transport procedure.

7051 3 7051 Remote controlled slewing crane with lifting magnet · One motor rotates the boom, another raises and lowers the load · Load hook and lifting magnet enable iron or iron-containing ob-

jects to be transferred by remote control · Boom adjustable manually for elevation · Working light in the control cab · Height 10 1/2" · Base 3 1/2" x 3 1/2" · 1 combined control and switch panel · Price does not include locomotives, cars or tracks

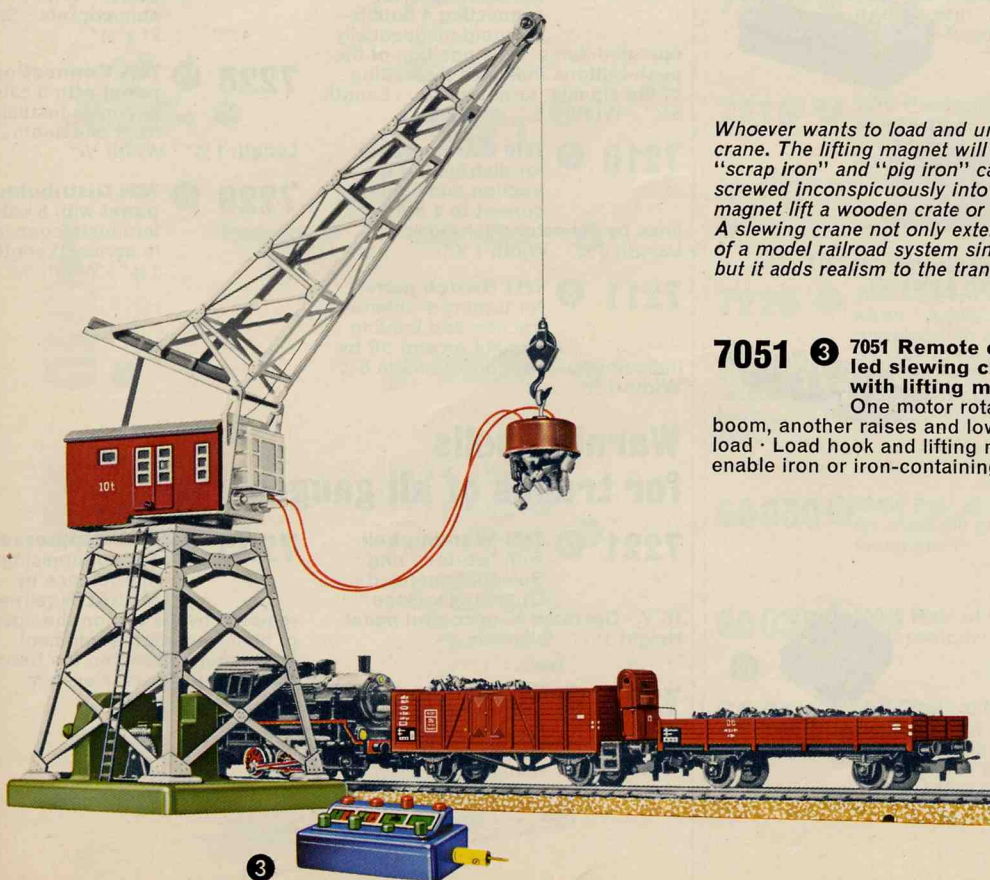

3

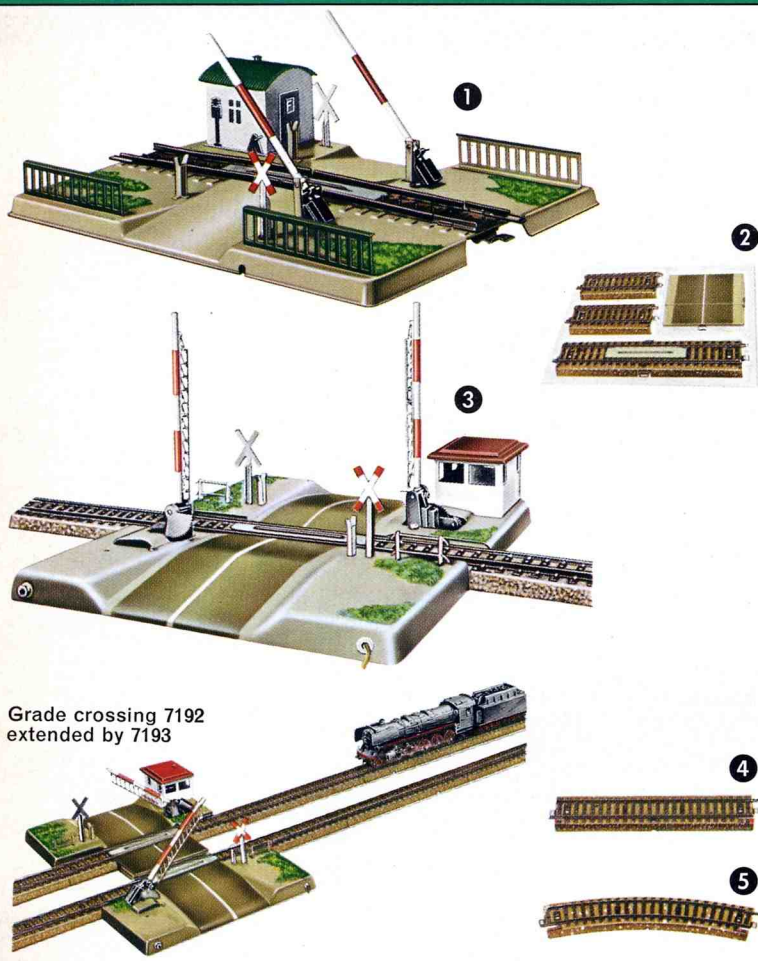

Grade crossing 7192 extended by 7193

Grade crossings with automatic gates

7390 ① 7390 Mechanically operated grade crossing for single-track lines made with M-track sections. The gates are closed by floating bars pressed down by the wheels of the passing train. The length of track section in the grade crossing is equal to the length of a track section 5106. Base $4\frac{3}{4}'' \times 7''$

7192 ③ 7192 Fully automatic grade crossing with M-track sections. The set consists of 2 electromagnetically operated gates with guard shed (designed to take interior lighting), warning crosses and a set of contact track sections (2 straight track sections)

7193 ② 7193 Extension set for the fully automatic grade crossing 7192, for each extra parallel track. Consisting of a set of contact track sections and adapters which can be fitted between the two tracks

Guarded grade crossing with automatic gates. As soon as the train approaches the crossing and runs on to the contact track sections, the gates close. They open again only after the last car has left the last section of contact track after the crossing.

The grade crossing 7192 together with the extension set 7193 can also be arranged for use with several tracks. In this case, it still operates automatically.

Contact track sections

5115 ④ 5115 Straight. Length $7''$

5116 ⑤ 5116 Curved. Radius $15''$

These M-track sections are for extending the contact sections of the grade crossing 7192.

Adapter track section 2191 (see page 52) enables K-track 2100 to be connected to the grade crossings 7192 and 7390.

Accessories for remote operation

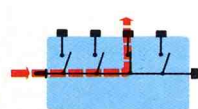

Circuit diagram for 7210 (switch 3 closed)

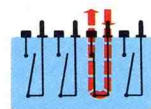

Circuit diagram for 7211 (switch 3 closed)



7072 ⑥ 7072 Control panel with 8 sockets for connecting 4 double-solenoid magnetically operated items. The position of the push-buttons indicates the setting of the signals, turnouts, etc. Length $3\frac{1}{4}''$. Width $1\frac{1}{4}''$

7209 ⑨ 7209 Distributor panel. With 11 single-pole sockets. Size $2'' \times \frac{3}{8}''$

7210 ⑦ 7210 Switch panel for distributing the traction and lighting current to 4 different lines by indicator push-buttons. Length $3\frac{1}{4}''$. Width $1\frac{1}{4}''$

7228 ⑩ 7228 Connecting panel with 5 cable terminals insulated from one another. Length $1\frac{1}{2}''$. Width $\frac{3}{8}''$

7211 ⑧ 7211 Switch panel for turning 4 different traction and lighting circuits on and off by indicator push-buttons. Length $3\frac{1}{4}''$. Width $1\frac{1}{4}''$

7229 ⑪ 7229 Distributor panel with 5 cable terminals connected in series. Length $1\frac{1}{2}''$. Width $\frac{3}{8}''$

Warning bells for tracks of all gauges

7221 ⑫ 7221 Warning bell with two-tone ring. Solenoid operated. Operating voltage 16 V. Operated from control panel. Height $1\frac{3}{8}''$. Diameter $2''$





7223 ⑬ 7223 Suppressor. For suppressing radio interference by MÄRKLIN railways, as required by the law on the operation of high-frequency equipment. It is incorporated between the transformer and the track system. $1\frac{7}{16}'' \times 1\frac{3}{8}'' \times \frac{3}{4}''$

7222 ⑬ 7222 Warning bell with two-tone ring. Hand operated. Height $4''$. Base diameter $1\frac{1}{2}''$

Rubber tires

- 7152** for locomotives
3005, 3048, 3089, 3091, 3094, 3098
- 7153**
3003, 3015, 3016, 3022, 3030, 3034, 3035, 3036, 3037, 3038, 3039, 3040, 3043, 3046, 3047, 3050, 3054, 3064, 3065, 3095, 3096
- 7154**
3000, 3021, 3031, 3044, 3051, 3055, 3060, 3061, 3066, 3067, 3068, 3071, 3072, 3075, 3076, 3078, 3080, 3087, 3090

Light bulbs

- 60000**  for locomotives
3005, 3015
- 60001**  3071, 3076
- 60010**  3000, 3003, 3016, 3021, 3031, 3046, 3047, 3048, 3064, 3065, 3072, 3095, 4018
- 60015**  3022, 3030, 3034, 3035, 3036, 3037, 3038, 3039, 3040, 3043, 3044, 3050, 3051, 3054, 3055, 3060, 3061, 3066, 3067, 3068, 3071, 3075, 3076, 3078, 3089, 3091, 3094, 3096, 3098, 4060, 4061

Current pickup shoes

- 7164** for locomotives
3016, 3022, 3034, 3035, 3036, 3037, 3038, 3039, 3040, 3043, 3050, 3051, 3054, 3055, 3066, 3067, 3068, 3071 front, 3072, 3075, 3076, 3096
- 7166**
3044, 3078, 3080, 4060, 4061
- 7173**
3005, 3030
- 7175**
3015, 3046, 3047, 3071 rear, 4018
- 7183**
3021
- 7185**
3000, 3003, 3031, 3048, 3060, 3061, 3064, 3065, 3087, 3089, 3090, 3091, 3094, 3095, 3098

Reverser unit springs

- 7194** Pack with 5 springs for reversing switch

Instructions for fitting rubber tires, current pickup shoes, light bulbs and reverser unit springs are given in the locomotive instructions.

Whistle for MÄRKLIN locomotives, see page 62



- 7218** **1** **7218 Pantograph, double arm** · 1 cheese-head screw
- 7219** **2** **7219 Pantograph, single arm** · 1 cheese-head screw · The catenary system must be set very carefully when using 7219 · At crossings, only the crossing section 7277 must be used
- 7220** **3** **7220 Current pickup shoe** · Additional requirement in order to be able to negotiate the curved turnout 2167 with the railbus trailer 4018 or with coaches having the interior lighting 7074 · Length 1"
- 60030** **4** **60030 Pair of brushes** for most HO gauge locomotives
- 60035** **60035 Pair of brushes** for locomotive 3015
- 60054** **60054 Pair of brushes** · Consisting of 2 graphite brushes for locomotives with permanent magnet motors
- 7199** **5** **7199 Oil bottle** · Contains about 1 oz. of lubricating oil for locomotives, cars and coaches
- 0241** **6** **0241 Smoke fluid** in plastic capsule as refill for the locomotives 3046, 3047, 3048 and 3091
- 7001** **7** **7001 Coupling gauge** made of nickel-plated steel sheet for checking locomotive and car couplings
- 7195** **8** **7195 Number plate set** · For identifying turnouts and signals in the track layout · Contents: 12 bases, with slots to hold the numbers 1-24 which are supplied
- 7224** **NEW** **9** **7224 Locomotive positioning device** · Plastic · Facilitates placing multi-axle locomotives on the track · Length 12" · Height 1"

Electric interior lighting

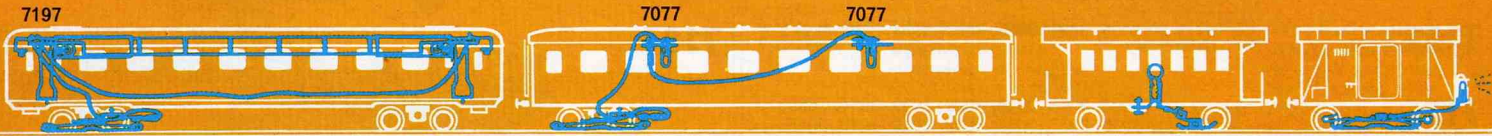

(7197 for 4050, 4072 and 4073)

7198

7074

7076

7079

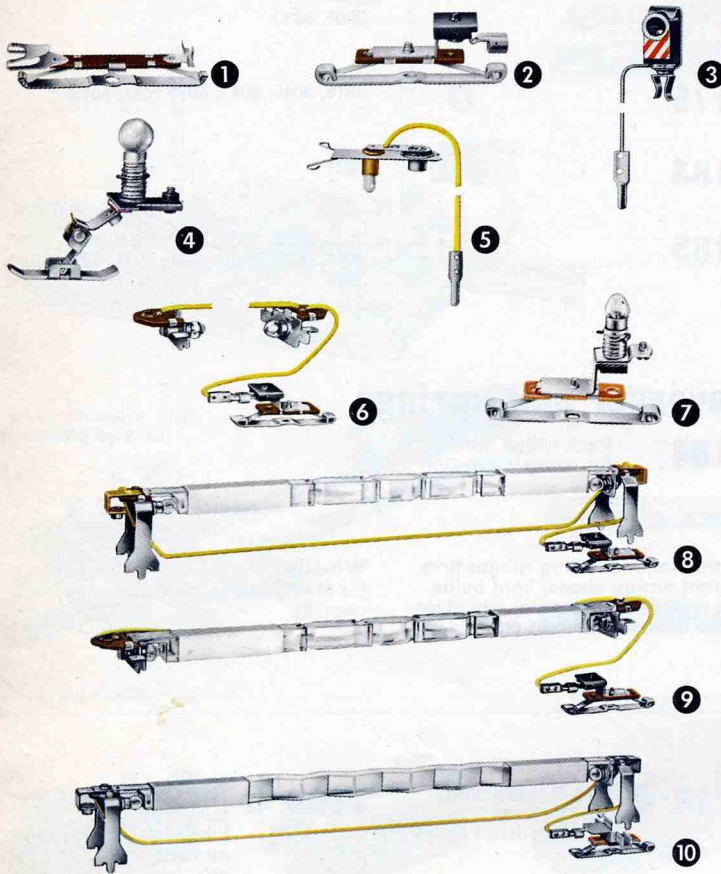

7076 ① **7076 Pickup shoe** for taillight 7079, for passenger cars 4000 and 4040 and two-axle freight cars only

7198 ② **7198 Pickup shoe** for the interior light fitting 7077

7079 ③ **7079 Taillight** with bulb · Clips on to buffer · For use on cars with metal buffers only · Requires 7074, 7076, 7077 or 7198

7074 ④ **7074 Interior light fitting** for passenger cars 4004, 4005, 4079 and 4080, featuring socket for additional lights, with bulb

7077 ⑤ **7077 Interior light fitting** for most long-distance coaches · With socket for additional lights and bulb

7322 ⑥ **7322 Interior light set** for TEE coach 4090 · Comprising pickup shoe 7198, two lamp sockets, 2 bulbs and installation instructions

7323 ⑦ **7323 Interior light fitting** for cars 4007 and 4008, with bulb

7197 ⑧ **7197 Interior light set** for long-distance coaches 4050, 4072 and 4073 · Comprising pickup shoe 7198, light diffuser, 2 lamp sockets, 2 bulbs and installation instructions

7320 ⑨ **7320 Interior light set** for TEE coaches 4085, 4086, 4087 and 4088 and long-distance coaches 4048, 4049, 4054, 4064, 4065, 4066, 4069, 4075 and 4078 · Comprising pickup shoe 7198, light diffuser, 2 lamp sockets, 2 bulbs and installation instructions

NEW

7324 ⑩ **7324 Interior light set** for long-distance coaches 4091 4092, 4093 and 4094 · Comprising pickup shoe, light diffuser, 2 lamp sockets, 2 bulbs and installation instructions

Whistle attachment for MÄRKLIN locomotives

A number of MÄRKLIN locomotives (see 7213) have provisions for mounting the whistle 7213. Signals can be sounded in the locomotive with the traction current switched off, by incorporating the whistle switch 7215 between transformer and track.

For sounding the whistle while the train is running, the whistle actuator 7216 is required. It should be arranged between transformer and whistle switch. The whistle can also be sounded while the locomotive is halted by a signal

with automatic train control. For this the halt control 7217 is required. Its two leads connect the controlled track section in front of the signal, with the remainder of the track system.

It is also possible for the locomotive to sound its whistle automatically by using the Universal Remote Control Switches 7045 or 7245 (see pages 51 and 55) and contact and/or switching track sections (see pages 48 and 52).



7213 **7213 Whistle**, complete · Suitable for MÄRKLIN locomotives 3022, 3034, 3035, 3036, 3037, 3038, 3039, 3040, 3043, 3050, 3051, 3054, 3055, 3060, 3061, 3066, 3067, 3068, 3071 and 3075, as well as for some models 3021 without any soldering · On the other locomotives 3021, a single soldered joint is required · Installation instructions are included · The power of the whistle is reduced if bulbs, e.g. coach interior lighting, are connected in the same circuit



7215 **7215 Whistle switch** · For sounding the whistle when the locomotive is stopped · Three leads, yellow, brown and red, each with plug · Dimensions 3" x 2 1/8" x 1"

Detailed operating instructions are included in the whistle switch set.



7216 **7216 Whistle actuator** · In conjunction with Whistle Switch 7215 it enables the whistle to be sounded when a locomotive is stopped or running · One red lead with plug · Dimensions 2" x 1 1/4" x 1"



7217 **7217 Halt Control** is required in addition to the Whistle Actuator 7215 if the whistle is to be sounded in a section of track from which the current has been switched off, e.g. in front of a signal · 2 red leads with plugs · Dimensions 2" x 1 1/4" x 1/8"



7280

NEW

7280 Street light, modern style · Height 4⁵/₈" · Base diameter 1" · With bulb



7281

NEW

7281 Station platform light, branched · Height 3⁷/₈" · Diameter of base 1" · With bulbs



7282

NEW

7282 Square and street light, branched · Height 4³/₈" · Diameter of base 1" · With bulbs



7283

NEW

7283 Lattice mast light, mounted on lattice mast, base plate for mounting onto K-tracks · Height 6³/₈" · With bulb



7284

NEW

7284 Sidewalk light · Height 2¹/₂" · Diameter of base 3¹/₈" · With bulb



7046

Base 1" x 1¹/₄" · With bulb

7046 Arc lamp on lattice mast · Can be used with catenary system · Height 8¹/₄" · With bulb



7048

7048 Arc lamp · Height 6³/₈" · Diameter of base 1¹/₄" · With bulb



7047

7047 Light · Height 5" · Diameter of base 1¹/₄" · With bulb

Commonly used lead colors for MÄRKLIN circuits



Red = For running trains (from transformer to center rail or catenary contact wire)



Yellow = Lighting and solenoid operated equipment



Brown = Ground lead from tracks and lighting sockets or from control panel to transformer



Blue = Ground lead from solenoid operated equipment to control panel or switching track (with green, red and orange plugs)

Leads

The copper conductor in this stranded lead consists of 24 separate strands each with a diameter of 4¹/₁₀₀₀" approx., giving a total cross-section which is fully adequate for all loads, even for a short circuit with a 50 VA transformer.

7100 Lead · Single conductor · 33' long · Grey

7101 Lead · Single conductor · 33' long · Blue

7102 Lead · Single conductor · 33' long · Brown

7103 Lead · Single conductor · 33' long · Yellow

7105 Lead · Single conductor · 33' long · Red

Sockets



7111 = brown
7112 = yellow
7113 = green
7114 = orange
7115 = red
7117 = grey

Plugs with side sockets



7131 = brown
7132 = yellow
7133 = green
7134 = orange
7135 = red
7137 = grey



7073 Lamp socket with bulb and lead, for stations, freight sheds etc.



7140 Adapter, for connecting two sockets or plugs



7000 Staples · Bag of 50 · For fastening leads to a wooden base



The heavy-duty MÄRKLIN transformers

The reliable insulation, tested at several thousand volts, makes every MÄRKLIN transformer absolutely safe. Furthermore, a built-in circuitbreaker switches off the current if there is a short-circuit in the layout or if the transformer is overloaded. The transformer can be plugged into the mains supply by means of the fitted cable and plug just as easily as any standard lamp.

The speed of the locomotives increases with the transformer output voltage, i.e., they go faster as you turn the red control knob to the right and slower as you turn it to the left. When the control knob is turned momentarily past the zero position on the left, the 24 V reversing circuit is activated and the locomotive reverses direction. (The "engineer" is built-in.) The trains can be run at a still slower speed with the 30 VA transformers of the 6100 and 6600 series than with the 16 VA transformers of the 6500 series.

We guarantee trouble-free operation of our railroads only when genuine MÄRKLIN transformers are being used.

The MÄRKLIN transformers of series 6100, 6500 and 6600 have connectors for train and lighting / solenoid equipment supply.

For A. C. mains only

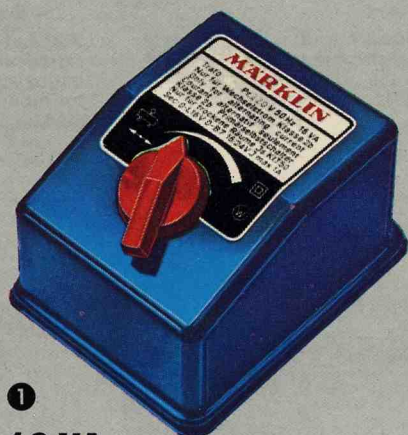

①
16 VA

16 VA ①

Transformer · Output 16 VA · Sheet metal case · Weight 3 lbs. · Dimensions 4 1/4" x 3 3/4" x 3"

- 6500 = 100 volts for Japan
- 6501 = 110 volts
- 6505 = 125 volts
- 6507 = 115 volts for USA

- 6509 = 240 volts for England
- 6511 = 220 volts
- 6514 = 220 volts for Finland

When ordering please quote the number corresponding to the required mains voltage.

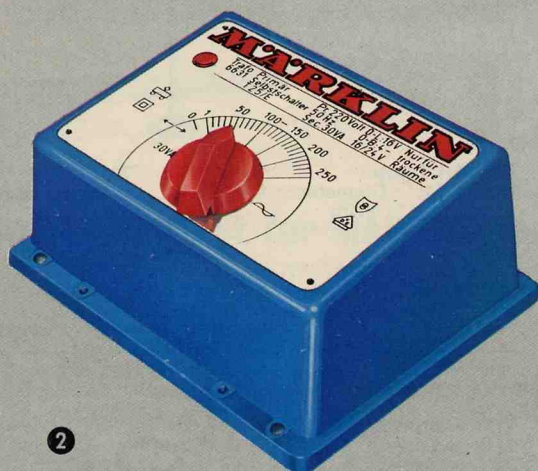

②
30 VA

30 VA ②

Transformer · Output 30 VA · Locomotive voltage infinitely variable between 4 V and 16 V · Lighting voltage 16 V · Plastic case · Red pilot light · Weight 4 1/2 lbs. · Dimensions 6 1/8" x 5 1/4" x 3"

- 6631 = 220 volts

NEW

When ordering please quote the number corresponding to the required mains voltage.

30 VA

Transformer · Output 30 VA · Sheet metal case · Red pilot light · Weight 4 1/2 lbs. · Dimensions 6 1/8" x 5 1/8" x 3"

- 6114 = 110 volts
- 6115 = 125 volts
- 6117 = 220 volts
- 6153 = 110 volts for USA
- 6158 = 100 volts for Japan
- 6166 = 240 volts for England
- 6197 = 220 volts for Finland



③
50 VA

Transformers for lighting

Up to 50 bulbs can be connected

50 VA ③

Transformer for lighting and solenoid equipment · Output 50 VA · Output voltage about 16 V A.C. · Sheet metal case · Weight 4 1/2 lbs. · Dimensions 6 1/4" x 5 1/8" x 3"

- 6211 = 220 volts

Power requirement for locomotives and lights

Examples:

This is how you can calculate how many items can be connected to the transformers: the 3-axle tank locomotive 3000 takes about 9 VA, the express diesel locomotive 3021 about 12 VA and the heavy express steam locomotive 3048 about 15 VA. Any transformer capacity left over by the locomotives can be used for lighting, with 1 VA counted as the power required for each bulb.

The transformer in the Gift Sets on page 10 has the same basic features as the transformers described here. The only difference is its lower output.

MÄRKLIN magazin

für große und kleine Modell-Eisenbahner - DM 1.90



The MÄRKLIN Magazine

The magazine for all model railroaders, young and old, reports on interesting topics connected with model railroads

The MÄRKLIN Magazine contains reports on real railroad practice and model railroad operation in interesting and stimulating articles. A lively, well illustrated magazine, it provides much worthwhile information for all model railroad enthusiasts, it gives useful hints and tips, it makes what seems complicated understandable, in short, with it, every model railroader can become a perfect model railroader. The MÄRKLIN Magazine is published quarterly in German. An annual subscription makes a welcome present.

Available from:

Modellbahnen-Welt Verlags-GmbH, 732 Göppingen, Postfach 940, Germany

or from your MÄRKLIN dealer, or through bookshops.



0380

0380 "MÄRKLIN HO Railroads and their Originals", a handbook for the MÄRKLIN model railroad fan. From the contents: Suggestions for designing landscaped model railroad layouts, the MÄRKLIN locomotives and cars and the originals on which they are modelled, signals, railroad regulations and procedures, examples of circuits e.g. simultaneous operation of several trains, and much more. 228 pages · 9 1/4" x 6 1/2". German text

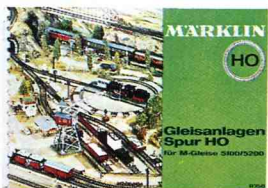

0351

0351 "MÄRKLIN HO Gauge Track Layouts for M-tracks 5100 and 5200". Apart from 20 track plans and detailed suggestions for construction, many combinations of turnouts and signals are explained and all possible variants shown. With 13 full-color illustrations of model track layouts. The text contains plenty of suggestions on how to plan even the biggest layouts. 86 pages · 8 1/4" x 11 1/4"

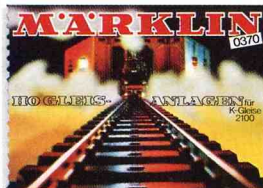

0371

0371 "MÄRKLIN HO Gauge Track Layouts for K-track 2100". With full-color illustrations and detailed track plans for 16 comprehensive layouts, including catenary system. The various circuits are shown in different colors. This publication also contains many plans of track section and turnout variants. An outstanding guide for building large layouts. 52 pages · 8" x 12"

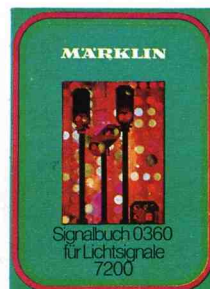

0361

0361 MÄRKLIN Signal Manual. This explains in detail, with the aid of 6-color illustrations, how signals and universal remote control switches of the 7200 series are incorporated into a system. 48 pages · 7" x 9 1/2"



0321

0321 "MÄRKLIN HO Gauge Track Layouts for M-tracks 5100 and 5200" with 16 simple track plans. This gives a good review of the design of basic track layouts and their variants. 24 pages · 8 1/4" x 6"



0379

0379 "MÄRKLIN HO Gauge Track Layouts for K-track 2100" contains 7 simple track plans. 20 pages · 6" x 8 1/4"

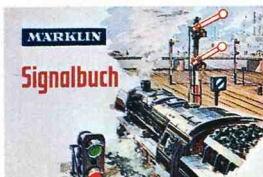

0341

0341 MÄRKLIN Signal Manual. This explains in detail, with the aid of 6-color illustrations, how signals and universal remote control switches of the 7000 series are incorporated into an M-track system. 44 pages · 6" x 8 1/4"

MÄRKLIN Brochures Available only from your MÄRKLIN dealer



4454

4452

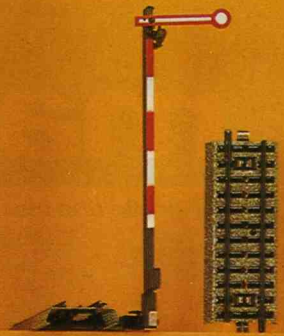

7400



3470



4450



4459



4453

4400



4401



3420



4451



3400



3450



Model narrow-gauge railroad using MÄRKLIN HO gauge track

3400

3400 Tank locomotive · Model of an 0-6-0 type narrow gauge locomotive of the Württemberg Railroad Co. (WEG) · All axles driven · 2 rubber tires to increase traction force · Exact reproduction of Allan valve gear · Reversing by remote control · Three working headlights on the front · Outstandingly detailed plastic body with many extras · Windows inset in plastic frames · Die cast zinc frame · Automatic coupling at each end with advance uncoupler (RELEX) · 5 1/2" long

3420

3420 Diesel locomotive · Model of an 0-6-0 type narrow gauge locomotive of the Southwest German Railroad Co. (SWEG) · Rear set of wheels driven · 2 rubber tires for increased traction force · Reversing by remote control · Three working headlights on the front · Plastic body · Plastic sheet in window frames · Die cast zinc frame · Automatic coupling at each end with advance uncoupler (RELEX) · 4 3/4" long

3450

3450 Passenger train (excl. transformer) · With tank locomotive 3400, 1 passenger car 4400, 1 passenger car 4401, 1 straight track section 5106, 1 feeder track section 5111 and 12 curved track sections 5200 · Length of train 20"

3470

3470 Freight train (excl. transformer) · With diesel locomotive 3420, 1 open freight car 4451, 1 dump car 4459, 1 straight track section 5106, 1 feeder track section 5111 and 12 curved track sections 5200 · Length of train 18 3/4"

4400

4400 Passenger car · Plastic body · 2 opening doors · Interior furnishings · Windows inset in plastic frames · 6 1/2" long

4401

4401 Passenger car · Plastic body · 2 opening doors · Interior furnishings · Windows inset in plastic frames · 6 1/2" long

4450

4450 Open freight car · 6 1/4" long

4451

4451 Open freight car · 6 1/4" long

4452

4452 Boxcar · Opening sliding doors on both sides · 6 1/2" long

4453

4453 Boxcar · Opening sliding doors on both sides · 6 1/2" long

4454

4454 Boxcar · Opening sliding doors on both sides · 6 1/2" long

4459

4459 Dump car · 2 dumping hoppers that can be independently tipped to either side · Hoppers lock in upright position · 6 1/4" long

7400

7400 Home signal · Operated by hand to move the semaphore arm and at the same time to control the current in the permanently connected track section, to start and stop the train · Additional track section, 3 1/2" long, with divided center conductor is included to form an insulated section at approach to signal · 2 1/2" wide · 3 1/2" long · 6 1/4" high

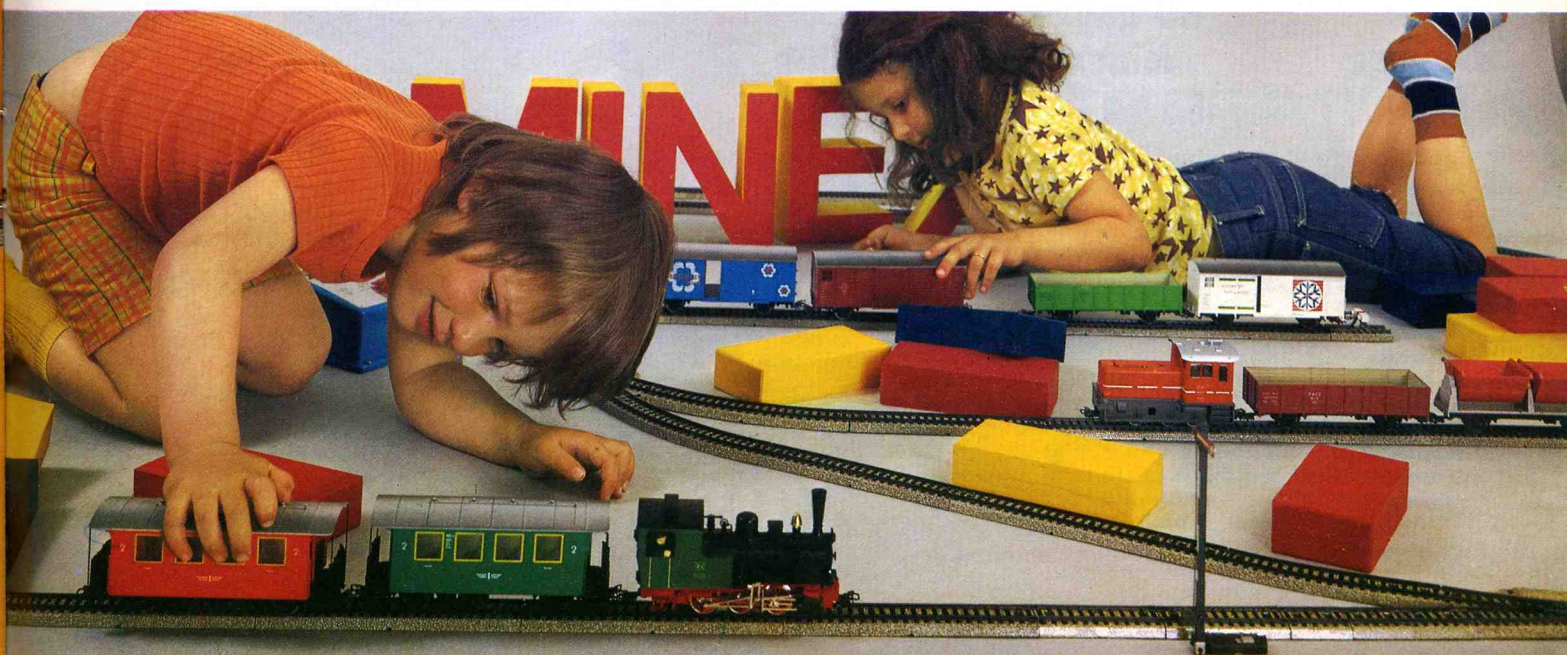



I gauge Scale 1:32 Two-rail A.C.

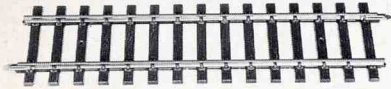

1



2

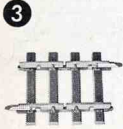

3

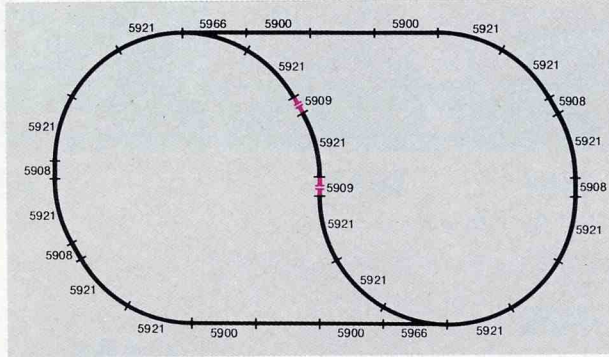

4

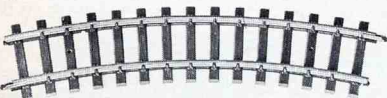

5

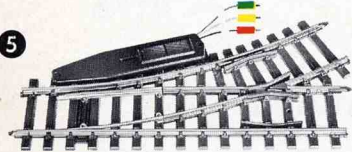

6

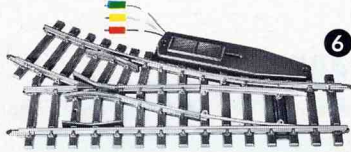

7

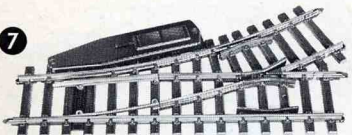

8

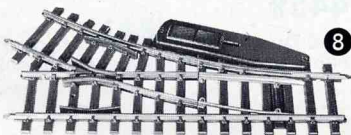

9

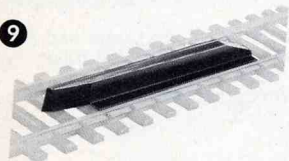

10



11



12



Track sections

The rails, mounted on plastic ties, not only guide the wheels but also supply the power to the locomotives. The track sections are connected by rail plus a clip on the base of the plastic tie strip. The rails are made of solid corrosion resistant sections, so the track can even be laid in the garden. Outside diameter of the rail circle 4" 2".

5900 1

5900 Track section, straight · 12" long

5965 7

5965 Manual left-hand turnout · Sprung switch points · Crossing angle 30° · Radius of the curved rails 24" · Length of straight track 12"

5908 2

5908 Track section, straight · 3 1/4" long

5966 8

5966 Manual right-hand turnout · Sprung switch points · Crossing angle 30° · Radius of the curved rails 24" · Length of straight track 12"

5909 3

5909 Divider track section, straight · For insulating individual track sections electrically · 3 1/4" long

5600 9

5600 Uncoupler · To be installed between the two rails of track section 5900 · Releases the coupling in one direction only, thus enabling kicking of the cars · 6 1/2" long

5921 4

5921 Track section, curved · Radius 24" · Curve 30°

5601 10

5601 Feeder set · Comprising 2 connector clips, with one red and one brown lead each and plugs at each end · 39" long

5962 5

5962 Solenoid controlled left-hand turnout · Operated by double solenoid · Sprung switch points · Crossing angle 30° · Radius of curved rails 24" · Length of straight track 12"

5602 11

5602 Track end bumper · Riveted steel construction · Sprung buffers · Clips on to rails · 3 1/4" long

5963 6

5963 Solenoid controlled right-hand turnout · Operated by double solenoid · Sprung switch points · Crossing angle 30° · Radius of the curved rails 24" · Length of straight track 12"

5603 12

5603 Clips · In packs of 28 · For securing the joints between I gauge track sections

In spite of the two conductor-rail system, the introduction of reverse loops, crossings and Y-tracks into the layout presents no polarity problem, because we have equipped the large MÄRKLIN model railroads with A.C. motors, which means that the advantages present in the MÄRKLIN H0 gauge railroads are also found here. As with the H0 gauge, reversing is effected in the locomotive. On the I gauge locomotive too, the "engineer" is built-in.

Comparison of sizes:

I gauge
45 mm (1 3/4")

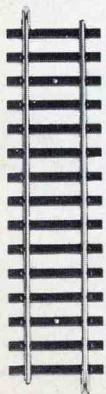

5900

H0 gauge

Minex
16,5 mm (5/8")



5100
M



2100
K

mini-club
6,5 mm (17/64")



8500

Comparison of sizes:

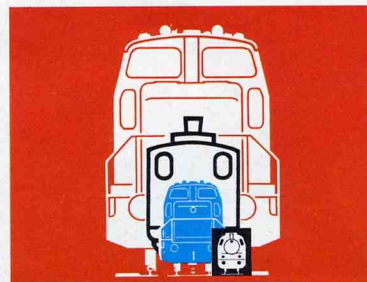

I gauge

Minex

H0 gauge

mini-club

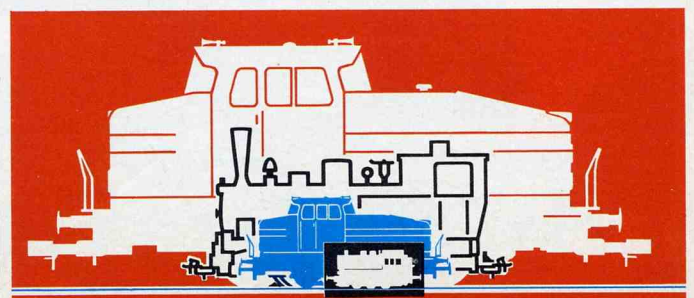

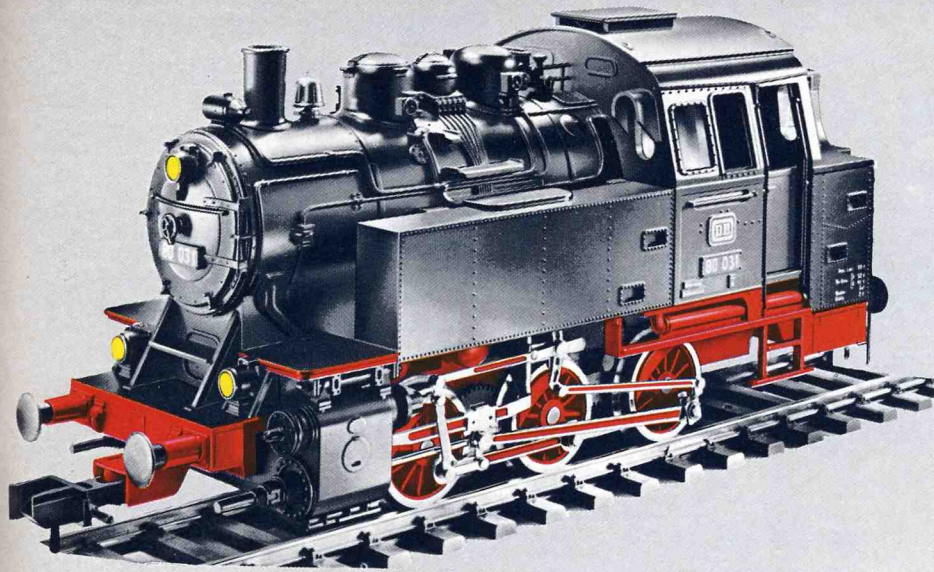

Tank locomotive

5700

5700 Tank locomotive · A model of the 0-6-0 type German Federal Railways' class 80 · 2 rubber tires for increased traction force · Detailed reproduction of the Heusinger valve gear · Reversing by remote control · Three working headlights on each end · Dull black plastic body · Opening cab doors · Windows of plastic sheet · Die cast zinc frame · Automatic coupling and sprung buffers at each end · Length over buffers 12"



Tank locomotive

5702

5702 Tank locomotive · 0-6-0 type · 2 rubber tires for increased traction force · Detailed reproduction of the Heusinger valve gear · Reversing by remote control · Three working headlights at each end · Plastic body, black boiler, water tanks and cab dark green, window frames and hand rails brass colored · Opening cab doors · Windows of plastic sheet · Die cast zinc frame · Automatic coupling and sprung buffers at each end · Length over buffers 12"



Diesel locomotive

5720

5720 Diesel locomotive · Model of an 0-6-0 type industrial locomotive · 2 rubber tires for increased traction force · Reversing by remote control · Three working headlights at each end · Red plastic body with two yellow horizontal stripes · Opening cab doors · Windows of plastic sheet · Die cast zinc frame · Automatic couplings and sprung buffers at each end · Length over buffers 12"

60 041

Pair of motor brushes for I gauge locomotives



① Passenger cars with interior furnishings

5800 ①

5800 Passenger car · Modelled on a private rail-road car · 2 opening doors · Simulated roof ventilators · Windows inset in plastic frames · Interior furnishings simulating wooden seats · 12 ¼" long

5801 ②

5801 Passenger car · Modelled on an original of the Royal Württemberg Railway · Otherwise similar to 5800



③ Freight cars

5850 ③

5850 Open freight car · A model of the German Federal Railways' (DB) type Omm 55 · 12 ¼" long

5851 ④

5851 Open freight car · Model of a Belgian State Railways (SNCB) freight car · 12 ¼" long

5855 ⑤

5855 Open freight car · Car body orange · Frame black · 12 ¼" long

5856 ⑥

5856 Open freight car · Car body light green · Frame black · 12 ¼" long

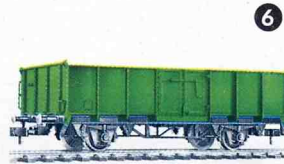
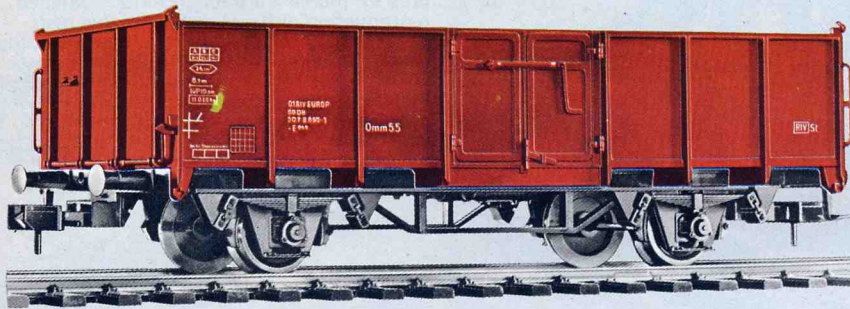

5853 ⑦

5853 Flat car · With removable stanchions · 12 ¼" long

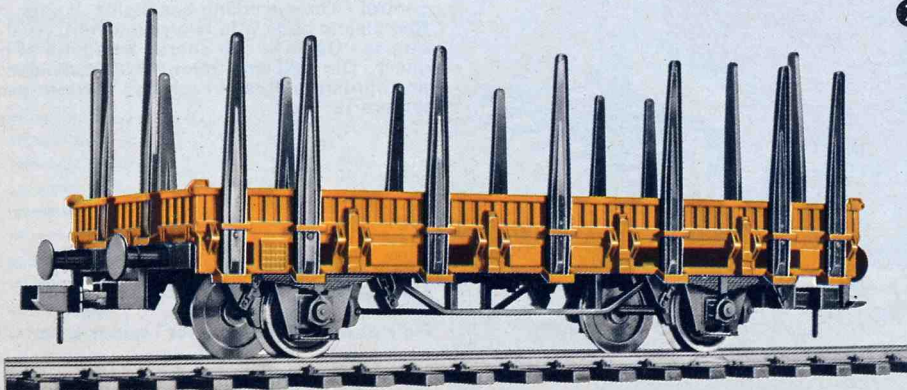



I gauge Two rail A. C. operation

1 Freight cars

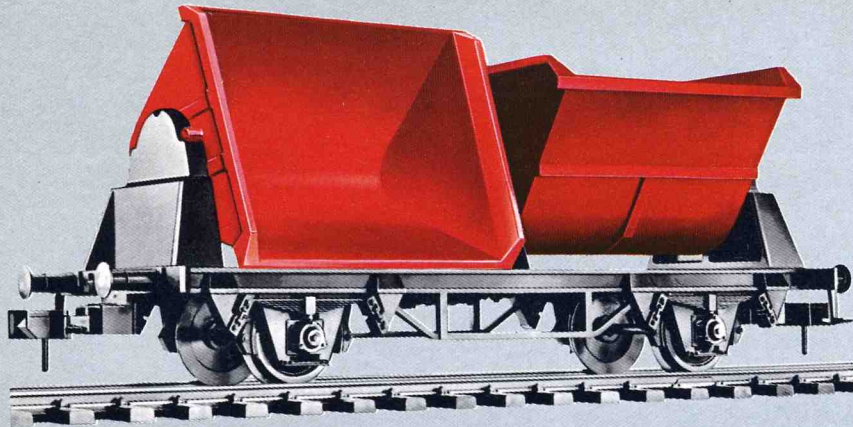

5859 ①

5859 Dump car · Two independent hoppers dump to either side · Latch holds hoppers in upright position · 12 1/4" long



5860 ② NEW

5860 Boxcar · Model of the German Federal Railways' (DB) type Gls · Opening doors on both sides · 12 1/4" long



③



④

5861 ③ NEW

5861 Beer car · Model of a private car belonging to the Dortmunder Union Brewery · Opening doors on both sides · 12 1/4" long

5862 ④ NEW

5862 Beer car "Staufenbräu" · Opening doors on both sides · 12 1/4" long

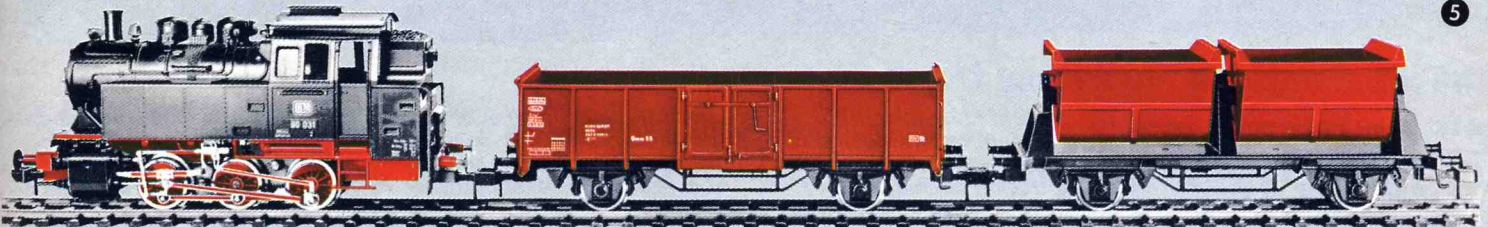

⑤

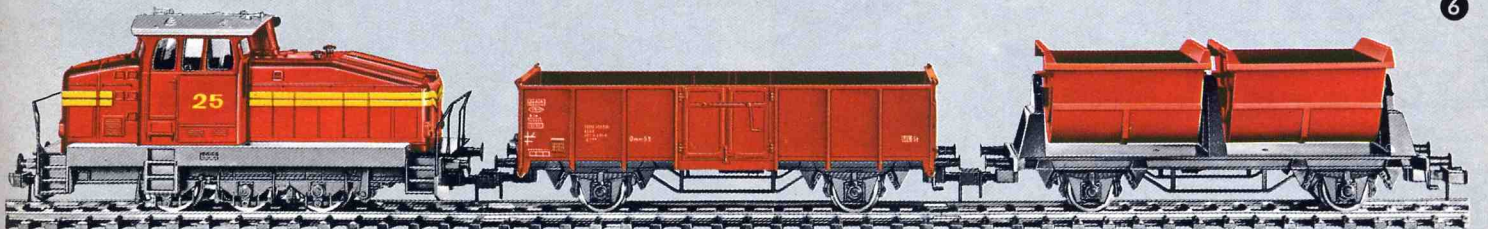

⑥

Train sets

5500 ⑤

5500 Freight train (excl. transformer) · Comprising tank locomotive 5700, 1 open freight car 5850, 1 dump car 5859, 2 straight track sections 5900, 12 curved track sections 5921 and 1 feeder connector 5601 · Length of train 40"

5520 ⑥

5520 Freight train (excl. transformer) · Comprising diesel locomotive 5720, 1 open freight car 5850, 1 dump car 5859, 2 straight track sections 5900, 12 curved track sections 5921 and 1 feeder connector 5601 · Length of train 40"

5521

5521 Freight train (excl. transformer) · Comprising simplified diesel locomotive, 1 dump truck 5859, 12 curved track sections and 1 feeder connector 5601 · Length of train 25"

The MÄRKLIN transformers 6114-6197 and 6631 are suitable for gauge I locomotives.



The ideal automobile racing track

1:32

MÄRKLIN
Sprint

The scale of 1:32 is just right because it requires a minimum of space for the MÄRKLIN-Sprint racing track. The course is quickly assembled and very rigid in the mechanical and electrical connections, thanks to the hinged locking couplings and spring conductor contacts. Although no retaining clips are used, the course will stand up well to extended and severe racing.

The track can be extended to two, four or six lanes, with long straightaways, or many banked or

unbanked curves, inclines, overpasses, lane crossovers, with or without automatic braking sections. Lap counters indicate the number of laps which have been covered by the race.

A comprehensive range of accessories is available to build up the most varied racing circuits—where necessary, with strong crash barriers for added protection.

Every MÄRKLIN racing car is a miniature masterpiece. The high speed motor is favorably located at the center of gravity, providing excellent roadability. In addition, the precision stepped gearing ensures sensitive response to all voltage variations. It enables short, sharp braking before curves and fast acceleration in the curve. It also gives superior hill climbing capability on the MÄRKLIN steep gradient stretch. MÄRKLIN racing cars achieve unbelievably fast lap times on this fully matched racing track.

Another feature typical of the superior MÄRKLIN quality is the solid skid-type pickup with compensating suspension system. This ensures positive contact and reliable and maintained power supply, at the same time cleaning the feeder-rails and the pickups themselves.

The tires of the cars can be changed and adapted to the surface characteristics of the course.

The speed controller is designed to provide infinitely variable speed regulation, or, with panel engaged, enables uniform up-stepping. In addition, using the built-in emergency stop-button, you can develop your own individual driving technique. The speed controller cable can be connected to the course at any point, at the choice of the "driver".

A host of valuable hints and tips for designing exciting courses are contained in the interesting MÄRKLIN-Sprint Manual. It also covers various "racing rules" for different types of racing on your own track, providing thrilling entertainment for all participants, young and old alike.

Running the small, lightning-fast racing cars with the merry, exciting struggle for victory is something quite different from the creative planning which characterises model railroads as a hobby. Because both these hobbies are so basically different, they complement one another, as a change.

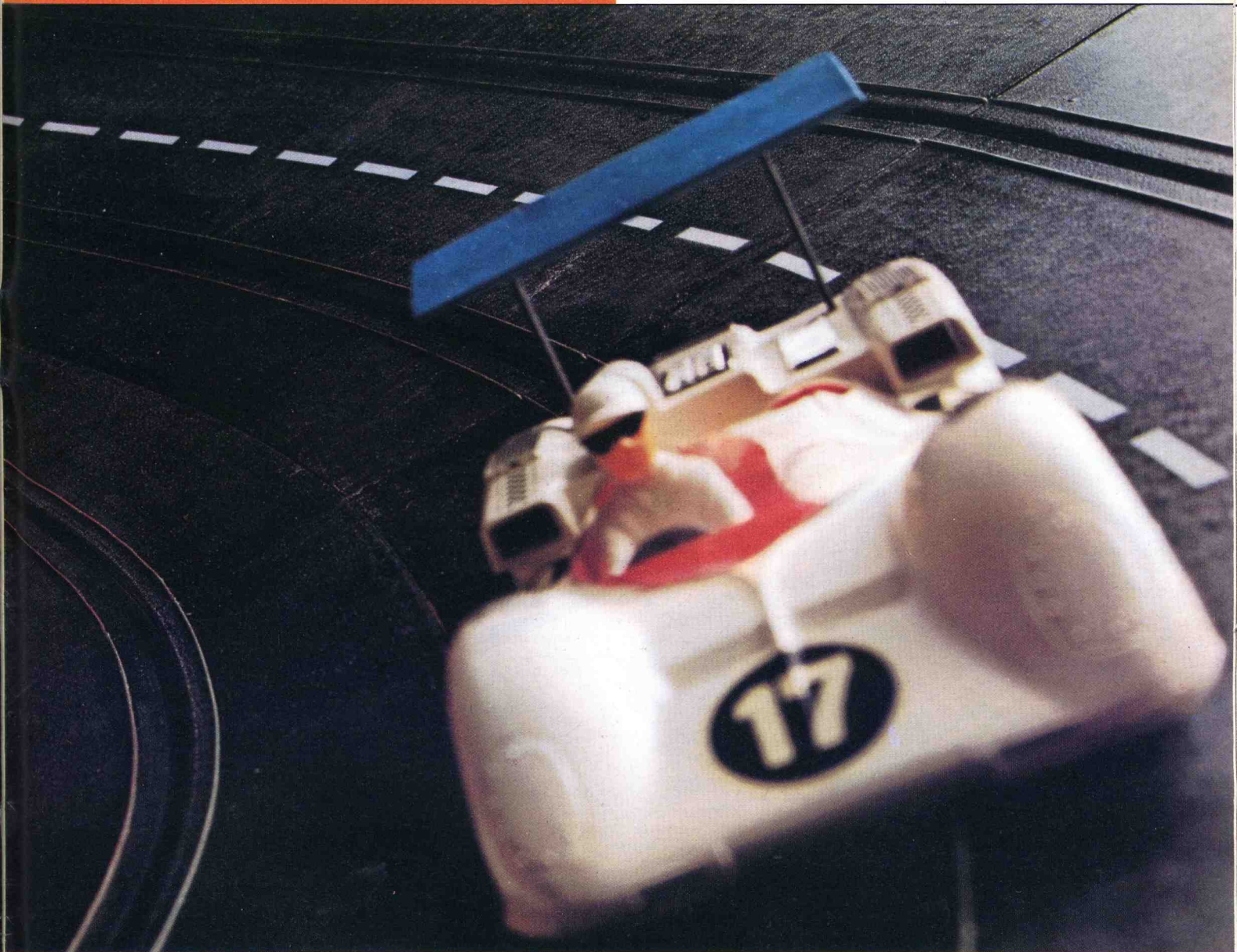

Gift Sets

All MÄRKLIN-Sprint sets come in these attractive gift boxes. Ask your

dealer for the racing track gift presentation box with this picture.

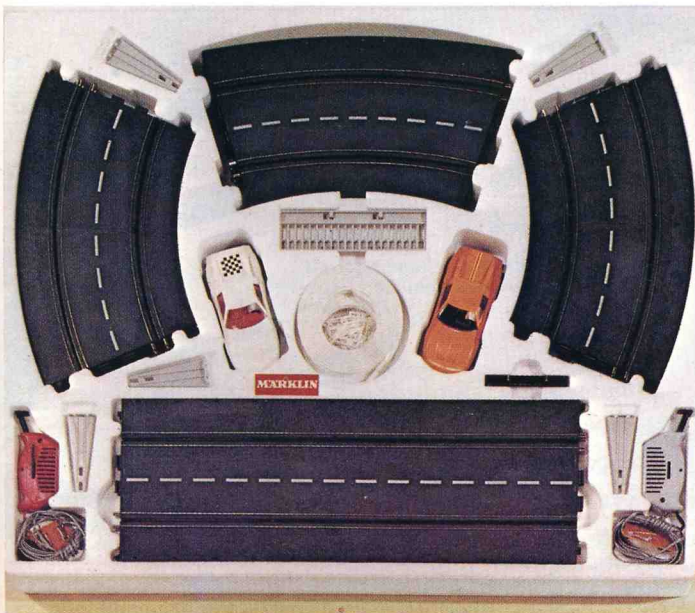

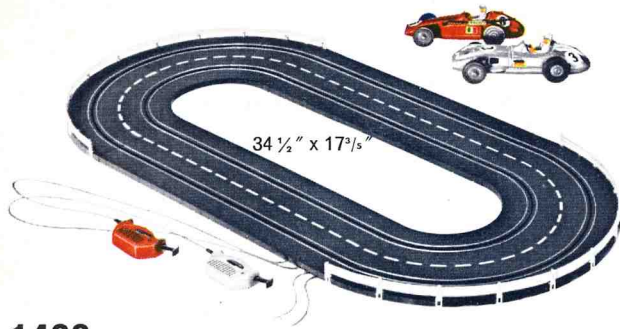

1400

1400 Racing track set · Comprising two formula racing cars, one Mercedes Monoposto and one Ferrari Supersqualo, two speed controllers, one red and one grey, 4 straight course sections 1200 and 4 curved course sections 1220, together with crash barriers and 20 crash barrier supports · These parts will make up an oval circuit · Full instructions are included

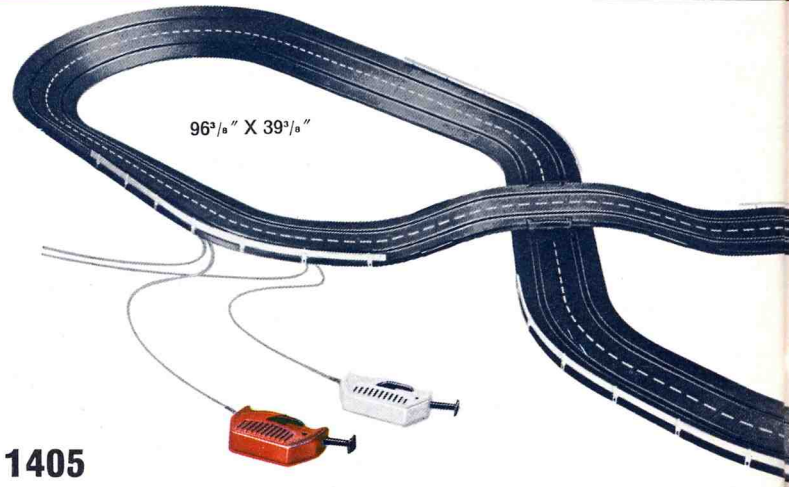

1405

1405 Racing track set with one steep turn · Comprising one white and one orange-colored Mercedes C 111, 1 red and 1 green speed controller, 2 straight course sections 1200, 4 straight sections 1201, 2 straight sections 1205, 8 curved course sections 1241, 4 steep turn sections 1248, 2 levelling out sections for start of incline 1290, 2 levelling out sections for end of incline 1291, crash barrier, 30 crash barrier supports, 4 fish plates 1547 and 2 clips · From this a figure-eight course with an overpass and one steep turn can be constructed · Full instructions are included

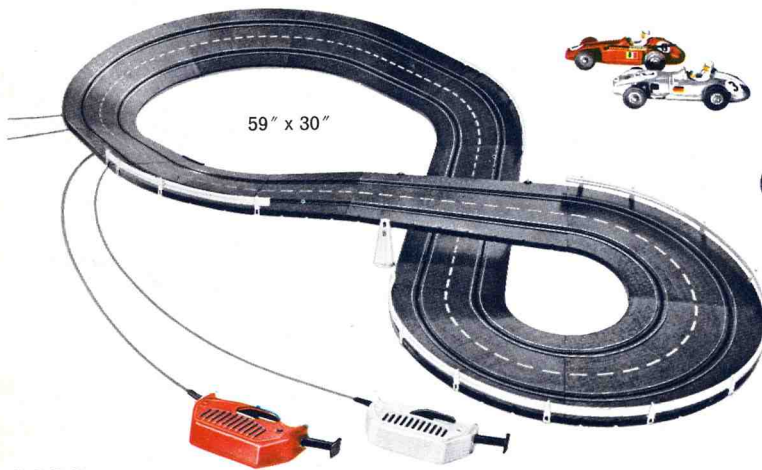

1409

1409 Racing track set with 1 steep turn · Comprising two formula racing cars, one Mercedes Monoposto and one Ferrari Supersqualo, 1 red and 1 grey speed controller, 2 straight course sections 1200, 2 straight sections 1201, 2 straight sections 1206, 3 curved course sections 1220, 2 curved sections 1241, 4 steep turn sections 1248, crash barriers, 19 crash barrier supports, 3 steep turn supports and 1 fish plate 1547 · These parts enable a large figure-eight course with overpass and 1 steep turn to be assembled · Full instructions are included

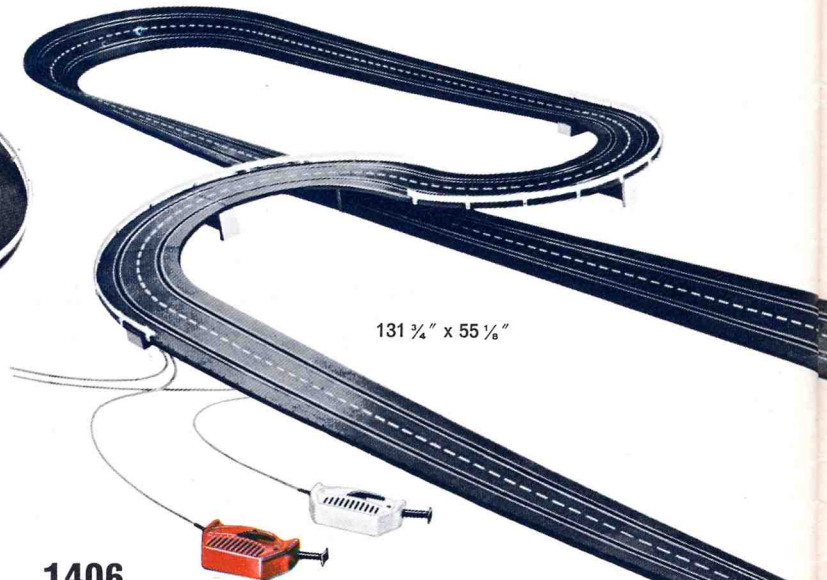

1406

1406 Racing track set with two steep turns · Comprising 1 white Chaparral sports car, 1 orange-colored open sports car, 1 red and 1 grey speed controller, 4 straight course sections 1200, 10 straight sections 1205, 8 curved course sections 1241, 8 steep turn sections 1248, 2 piers each 1 1/16" x 1 1/8" x 2 3/8" high, crash barriers, 30 crash barrier supports and 4 steep turn supports · These parts enable a large figure-eight course with an overpass and two steep turns to be assembled · Full instructions are included

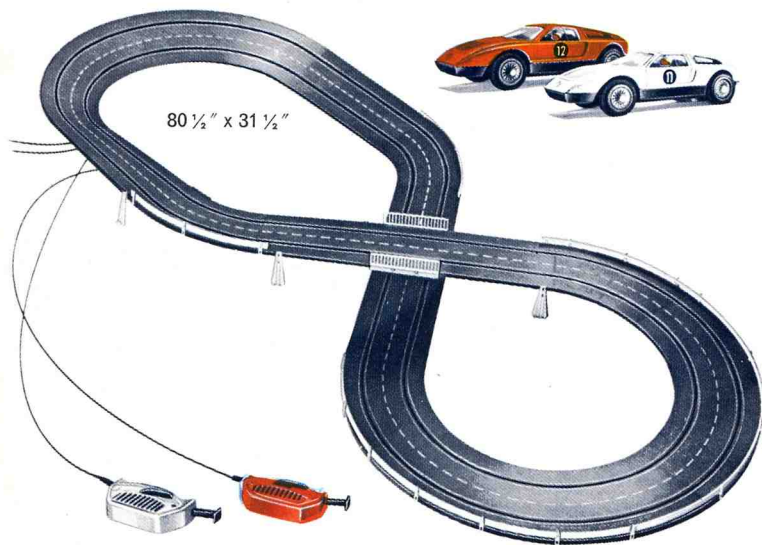

1412

1412 Racing track set with 1 steep turn · Comprising 2 Mercedes C 111 sports cars, 1 red and 1 grey speed controller, 2 straight course sections 1205, 4 straight sections 1206, 8 curved sections 1241, 4 steep turn sections 1248, crash barriers, 22 crash barrier supports, 2 bridge railings, 1 fish plate section 1547 and 5 steep turn supports · With these parts, a figure-eight course with overpass and 1 steep turn can be assembled · Full instructions are included

NEW



1410

1410 Racing track set · Comprising 2 Porsche 911 Targa sports cars, 1 red and 1 grey speed controller, 4 straight course sections 1205, 4 straight sections 1206, 10 curved sections 1241, 2 piers each 1 1/16" x 1 1/8" x 2 3/8" high, 4 bridge railings, crash barriers, 50 crash barrier supports · This enables a large figure-eight course with overpass to be constructed · Full instructions are included

The front wheels are steered by the slots in the course. Accurate reproduction of the suspension arm assembly. Current pickup by 2 sprung skids.



1300 1300 Formula racing car · Model of the Mercedes W 196 Monoposto · Driven through multi-ratio gearbox · Silver plastic body · 5" long · Spare tires for this car: front 1500, rear 1501 or 1504



1301 1301 Formula racing car · Model of the Ferrari Supersqualo · Driven through multi-ratio gearbox · Red plastic body · 5" long · Spare tires for this car: front 1500, rear 1501 or 1504



1302 1302 Sports car · Model of the Porsche Carrera 6 · Driven through a multi-ratio gearbox · White plastic body · Cockpit enclosed by clear plastic hood · 5 1/4" · Spare tires for this car: front 1500, rear 1503



1305 1305 Sports car · Model of the Porsche Carrera 6 · Construction as for 1302, but with red body



1308 1308 Sports car · Model of the Jaguar E type · Swing front axle · Driven through spur gears · Red plastic body · Inset windows · 5 1/4" long · Spare tires for this car: front 1500, rear 1503



1310 1310 Sports car · Model of the Porsche 911 T Targa · Swing front axle · Driven through spur gears · Orange plastic body · Inset windows · 5" long · Spare tires for this car: front 1500, rear 1503



1311 1311 Sports car · Model of the Mercedes C 111 · Swing front axle · Driven through spur gears · Body white with black chassis · Inset windows · 4 3/4" long · Spare tires for this car: front 1500, rear 1503



1312 1312 Sports car · Construction as for 1311, but orange body



1313 1313 Sports car · Construction as for 1302 but open cockpit with windshield · Body silver with black chassis · 5 1/4" long



1314 1314 Sports car · Construction as for 1313 but body orange with white chassis



1315 1315 Sports car · Model of the Chaparral 2E with rear stabilising fin · Driven through multi-ratio gearbox · White plastic body · 4 1/2" long · Spare tires for this car: front 1500, rear 1503



1316 1316 Sports car · Model of the Porsche Carrera 6 · Driven through multi-ratio gearbox · Silver plastic body · Two working headlights · Cockpit enclosed by clear plastic hood · 5 1/4" long · Spare tires for this car: front 1500, rear 1503



1317 1317 Sports car · Construction as for 1316 but open cockpit with windshield · Red plastic body · 5 1/4" long



NEW

1318 1318 Sports car · Porsche 911 T Targa as police car · Blue light · Swing front axle · Driven through spur gears · Green and white plastic body · Inset windows · 5" long · Spare tires for this car: front 1500, rear 1503

Straight sections

Two lanes · With feeder connector

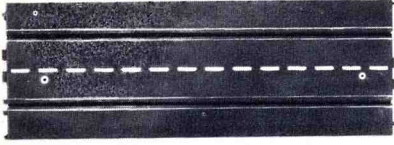

1205

16 3/8" long
(twice the length of 1200)

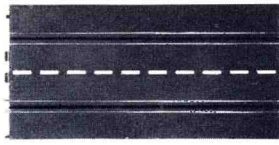

1206

12" long
(twice the length of 1201)

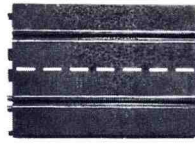

1200

8 3/8" long

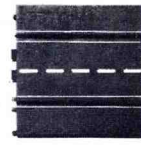

1201

6" long

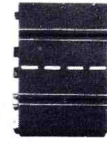

1202

4 1/8" long



1203

2 1/8" long



1204

1 3/8" long

All course sections are made of rigid plastic with slots for guiding the cars, current being supplied to the cars by contact rails arranged on both sides of the slots. Snap on links couple the sections of the track securely together. No additional braces required. The sections are black with a broken white line in the center.

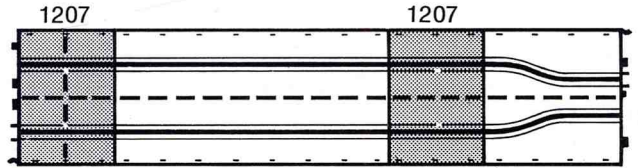

1207

Controlled zone set · Comprising 2 sections each 4 1/8" long · For use at approach to chicane or change lane sections · The first vehicle entering this zone automatically

cuts off the power to the other lane and restores it only after leaving the controlled zone

Chicane, straight section

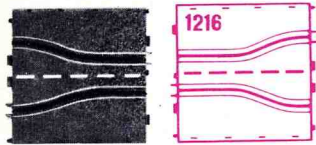

1216

Chicane, straight section · Two lanes · Track spacing reduced from 3" to 1 1/2" · 6" long · **Two of these track sections should be adjoining**

Change lane section, straight

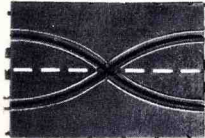

Change lane sections (1217, 1227, 1247) cannot be used singly. They should either be used in pairs, or in combination.

1217

8 3/8" long · Two lanes · The crossing conductor rails are electrically separated

Curved change lane sections

1227 ③ 90° change lane section · Two lanes · Mean radius 6"

1247 ④ 45° change lane section · Two lanes · Means radius 12"

The crossing conductor rails are electrically separated.

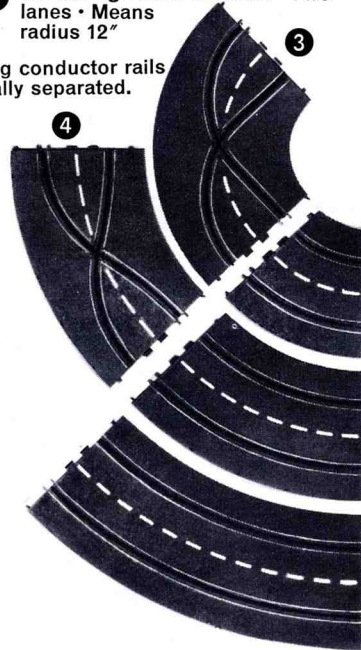

Curved course sections

1220 90° course section · Two lanes · Mean radius 6"

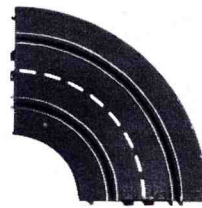

1221 45° course section · Two lanes · Mean radius 6"

1241 45° course section · Two lanes · Mean radius 12"

1261 45° course section · Two lanes · Mean radius 18"

Inclines



1290 ① **Straight levelling out section for start of incline** · Two lanes · Concave pattern · Final incline angle approx. 30° · 8 3/8" long

1291 ② **Straight levelling out section for end of incline** · Similar to 1290 but convex pattern · Including 1 bracket for stiffening the section

45° steep turn sections

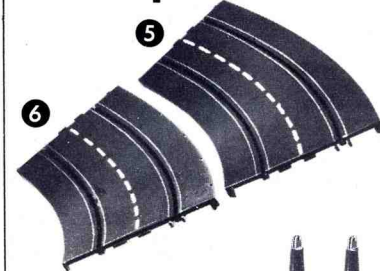

1268 ⑤ 45° steep turn sections · Two lanes · Mean radius 18"

1248 ⑥ 45° steep turn sections · Two lanes · Mean radius 12"

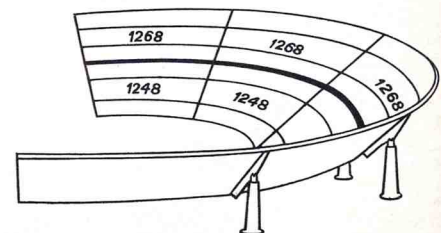

1546 **Set of steep turn supports** · Comprising 7 cross supports, 3 columns 5" high, 4 columns 3" high and 12 connectors · Plastic · Required for four-lane steep turns



1590 ① **1590 Speed controller** with fittings · Grey · Ergonomic design · Control button will engage to set various speeds · An emergency stop key enables the power to be disconnected without losing the control button setting · Built-in suppressor capacitor · The fittings comprise the connector plate with a 2-core lead 4 3/4" long to the speed controller and another 2-core lead 3 1/2" long with plug for connecting to the power supply unit · A speed controller must never be used for more than one car at a time

1591 ② **1591 Speed controller** · Similar to 1590 but colored red



6930 **6930 MÄRKLIN-Sprint D. C. power supply unit** · For use on 220 volts A. C. only · Output 14 volts D. C., approx. 10 Watts · Overload protection with automatic current limiter · Mains cable with moulded mains plug · Sheet metal case · On the output side, 2 pairs of sockets marked "Auto 1" and "Auto 2" · Weight 2 1/2 lbs. · Dimensions 5" x 3 3/4" x 2 1/16"

The use of this Power Supply Unit 6930 is recommended. If MÄRKLIN railroad transformers are used, it is essential to connect the rectifier 1592 between transformer and speed controller.

Important! MÄRKLIN-Sprint racing cars should be operated with D. C. supply only.



1592 **1592 Rectifier** · For use in conjunction with MÄRKLIN railroad transformers · Dimensions 2 1/4" x 2" x 1/16" · D. C. supply for operating up to 4 cars simultaneously can be taken from the two pairs of sockets marked "Auto 1" and "Auto 2". The transformer to be used should be rated 16 VA or more



1540 **1540 Crash barrier** · Flexible plastic corrugated section · White · 6 1/4" long



1541 **1541 Support for crash barrier** · White plastic · For mounting crash barriers to the course

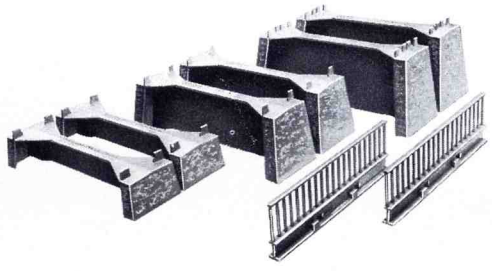

1542 **1542 Construction kit for overpass** · Comprising 2 piers 1 1/16" high, 2 piers 1 7/16" high, 2 piers 2 2/5" high and 2 bridge parapets · All parts grey plastic · A very strong overpass to span even multi-lane courses



1543 **1543 Pier** · 2 2/5" high · Grey plastic · Mounting stubs on top engage in course sections

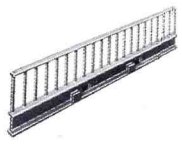

1544 **1544 Bridge parapet** · For reinforcing overpasses · Grey plastic · 5 7/10" long · 1 1/2" high



1545 **1545 Mechanical lap counter** · On 4 7/10" long 2-lane section long · Displays up to 99 laps for each lane in either direction · Can be zeroed by hand · 5 7/10" high · 6" wide · A section 1202 is required to compensate for the length · On multi-lane courses, several lap counters can be arranged in line



1547 **1547 Fish plates** · 2 7/10" long · Black plastic · For connecting two adjoining straight sections and reinforcing the joints

Tire sets

- 1500** Comprising 2 rubber tires, 20.5 mm diam. x 6 mm · For models 1300, 1301, 1302, 1305, 1308, 1310, 1311, 1312, 1313, 1314, 1315, 1316, 1317, 1318
- 1501** Comprising 2 rubber tires, 23 mm diam. x 7 mm · For models 1300, 1301
- 1503** Comprising 2 rubber tires, 20.5 mm diam. x 7.6 mm · For models 1302, 1305, 1308, 1310, 1311, 1312, 1313, 1314, 1315, 1316, 1317, 1318
- 1504** Comprising 2 rubber tires, 24 mm diam. x 8.4 mm · For models 1300, 1301

Adaptation pickup skids

1510 (1 pair) · Mount on pickup skids of MÄRKLIN-Sprint cars to adapt them for tracks of other makes

Motor brushes

60146 Set of two brushes for MÄRKLIN-Sprint car motors

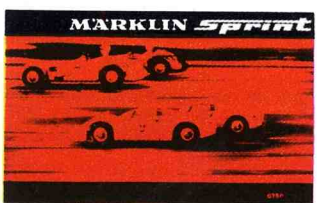

0751 **0751 MÄRKLIN-Sprint Racing Track Manual** · With suggestions for designing racing courses. Includes rules for racing and interesting illustrations · 44 pages · 8 3/4" x 11"



MÄRKLIN miniature automobiles made of die cast metal with working parts and special smooth running wheels

These models are precision engineered down to the last detail. Opening doors, hoods and trunk lids, windows glazed, full interior. "rak" models have a special finish to ensure particularly smooth operation. "rak"—that is **Real Automobile Knack**.

Ask your dealer for the special saver featuring the full range of MÄRKLIN "rak" miniature automobiles.

1972 Range

- | | | | |
|------|---|----------|---|
| 1800 | Porsche 911 T Targa | 1817 | Mercedes 250 |
| 1801 | BMW 2000 CS | 1818 | Chevrolet Corvette |
| 1802 | Chaparral 2 F | 1819 | BMW 2002 ti |
| 1803 | Ford OSI 20 MTS | 1820 | BMW 2500 |
| 1804 | BMW 2800 CS | 1821 | Audi 100 LS |
| 1805 | VW-Variant 1600 | 1822 | Ford Capri 2300 |
| 1807 | VW-Variant 1600—fire chief vehicle | 1823 | VW-Variant 1600—police vehicle |
| 1808 | VW-Variant 1600—ADAC, road assistance vehicle | 1824 | Caravan |
| 1809 | VW-Variant 1600—Red Cross ambulance | 1825 | VW 411 |
| 1810 | Porsche 910 | 1826 | VW-Porsche 914 |
| 1811 | NSU Ro 80 | 1828 | Mercedes 250—police vehicle |
| 1812 | BMW 1600 GT | 1829 | Mercedes 250—Taxi |
| 1813 | Mercedes C 111 | 1830 | Unimog platform |
| 1814 | BMW 3000 | 1831 | Unimog platform with accessories, 6 parts |
| 1815 | Porsche 907 | 1834 | Audi 100 Coupé |
| 1816 | Matra M 530 | 1835 | Opel Manta |
| | | 1837 | VW K 70 |
| | | 1838 | Model Rally 1600 GT |
| | | NEW 1839 | Mercedes 350 SL |



MÄRKLIN Metal Construction Sets

Prepare for the future while playing

The technology of the future will determine the quality of life to such an extent that it is as well for the young to prepare themselves for it early.

MÄRKLIN metal construction sets provide a good way of learning about technical things while playing. Their recognized advantages reside on the one hand, in the educationally well thought-out system of having five basic sets, each intended for a particular age group and, on the other hand, in having the right parts, accurately reproduced from the parts used in practice and assembled with the right bolts, again as in practice.

This grading by age and this technical realism are very important factors. They mean that a child as young as five, while playing, becomes aware of the very simplest relationships and can continue and increase his knowledge until he has a clear conception of the laws of mechanics and (from set 1013) of electricity, and this always with due regard to his age and as his set is being built-up.

A MÄRKLIN set not only arouses enthusiasm because of its unlimited possibilities and realistic components, but it is of real assistance in providing practical knowledge.

1010



1012



1011



1013

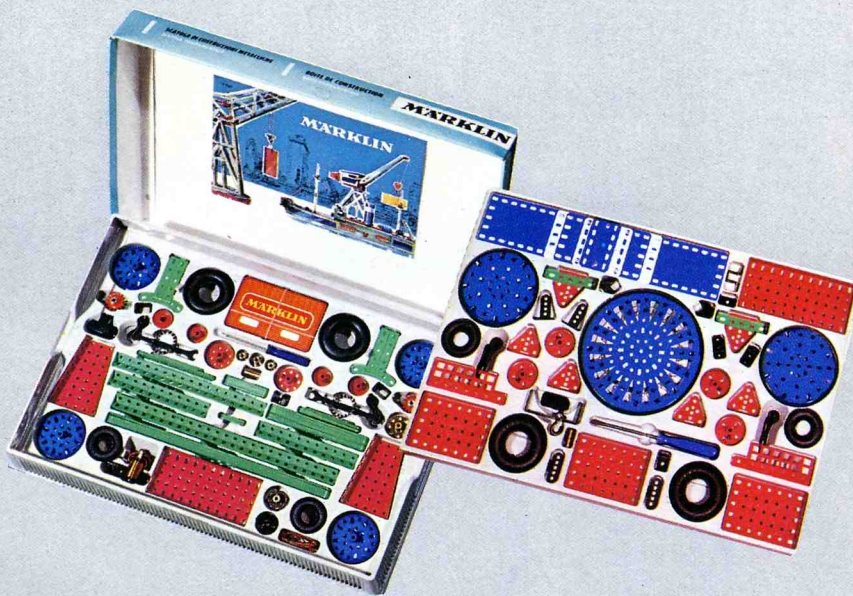

MÄRKLIN metal construction sets with real bolt assembly

1010

1010 Basic set for children from 5 years upwards · Comprising 176 construction parts · Size 16" x 12" x 1 1/4" · Weight 2 lb. 5 oz. · Even this smallest set enables more than 90 models to be built, including trucks, windmills, cranes etc. · In the process it teaches what pulley blocks, gear ratios and couplings are · Can be made up to Basic Set 1011 by adding Module Kit 1030

1011

1011 Basic set for children from 6 years upwards · Comprising 242 construction parts · Size 20 3/4" x 13 3/4" x 1 1/4" · Weight 3 lb. 14 oz. · All sorts of mechanical models can be built with this set, the range extending from scooter to logging truck, from weighing machine to cable car, from excavator to mobile crane, with everything true to original and fully working · Can be built up to Basic Set 1012 by adding Module Kit 1031

1012

1012 Basic set for children from 7 years upwards · Comprising 396 construction parts · Size 20 3/4" x 13 3/4" x 1 1/2" · Weight 6 lb. 13 oz. · Set 1012 enables the child to make even more detailed models such as diesel locomotives, large trucks, tower crane, windmills, drilling machines etc. · A good appreciation of the laws of mechanics is achieved · Can be built up to Basic Set 1013 by adding Module Kit 1032

1013

1013 Basic set for children from 10 years upwards · Comprising 703 construction parts · Size 20 3/4" x 14 1/4" x 2 1/8" · Weight 11 lb. 11 oz. · From this set onwards, electrical components are included, such as commutator, solenoid, cable, etc. · A "Short Course in Electricity" gives an introduction to the basic principles of electricity and electromagnetism and many models enable this new knowledge to be applied · Can be built up to Basic Set 1014 by adding Module Kit 1033

The MÄRKLIN construction set is of high quality proprietary make

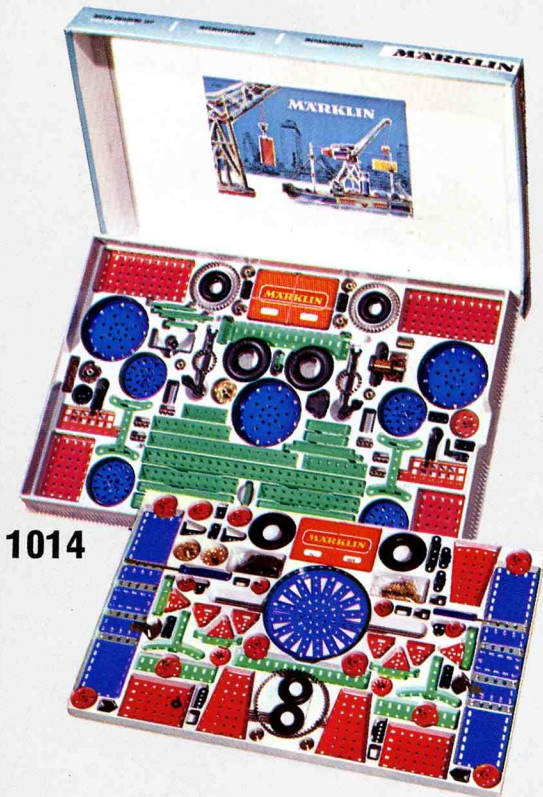

1014



1034

1014

1014 Basic set for children from 10 years upwards · Comprising 1006 construction parts · Size 25 1/4" x 16 1/8" x 2 3/8" · Weight 16 lbs. 4 oz. · The contents of this set are for enthusiasts, young or old alike · Its capabilities at this stage include impressive models built up out of hundreds of separate parts · It is also possible to make mechanical and physical models based on strictly scientific principles · Can be built up one stage further by adding module kit 1034

Module kits

Any basic set can be built up to the next larger one by adding a module kit, whose contents added to the existing basic set make up the new larger basic set. If, e.g., you have the basic set 1010 and would like to make it up to the basic set 1011, then you would require module kit 1030.

In brief:

- | | |
|---|---|
| Module kit 1030
converts basic set 1010 into set 1011 | Module kit 1032
converts basic set 1012 into set 1013 |
| Module kit 1031
converts basic set 1011 into set 1012 | Module kit 1033
converts basic set 1013 into set 1014 |

1034

1034 Module kit extends basic set 1014 a stage further

Apart from the module kits mentioned above, every MÄRKLIN metal construction set can be amended by individual parts if your set does not have enough parts for a particular model you wish to make, or by special parts which are not included in the sets. A special saver of these parts, as well as the parts themselves, can be obtained from any toyshop which stocks MÄRKLIN products.

Number of construction items in the MÄRKLIN metal construction sets

Basic set No.	No. of items	Module kit No.	No. of items
1010	176	1030	67
1011	242	1031	164
1012	396	1032	308
1013	703	1033	307
1014	1006	1034	1100

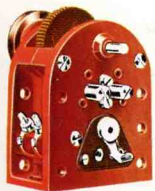

1071



1072



Electric motors for use with construction sets

It is a particular pleasure to any youngster to make the models which he has built in accordance with the Instruction Book or his own ideas, work under power. The two electric motors illustrated can be used to power models in this way, including those assembled from the smallest basic set.

1071

1071 Electric motor · Reversible, for clockwise or anticlockwise rotation · No-load speed about 1500 r.p.m. · Runs on 16 volts, so it can be connected to any MÄRKLIN H0 gauge railroad transformer · Accessories: 2 cables · 2 1/2" high · 2" wide · 2" long · Weight 7 oz.

1072

1072 „Elex" electric motor · 16 volt · With lead and reversing switch · Two cord pulleys running in opposite directions at different speeds, infinitely variable by the transformer · No-load speed 3000 and 1100 r.p.m. · Extremely powerful motor, suitable for driving the largest models made up from the construction sets, as well as working models of all types · 3 connectors · 2 1/2" high · 3 1/4" long · 2 1/2" wide · Distance between pulley grooves 3 1/2" · Weights 23 1/2 oz.

