

Märklin



1975 E

In this catalogue you will find:

Märklin

Märklin mini-club

mini-club SET program
Locomotives, cars
Accessories

1—17
2— 6
7—10
11—17

Märklin I gauge

Locomotives, coaches, train sets,
tracks, accessories

78—79

Gebr. Märklin & Cie. GmbH

732 Göppingen/Germany
Manufacturers of high
quality toys

Märklin HO

HO-gauge system, explanatory information
Publications, HO-gauge
SET-HO extension program
Train sets, HO-gauge
Locomotives, HO-gauge
HAMO locomotives, information
Accessories for locomotives, HO-gauge
Passenger coaches, HO-gauge
Freight cars, HO-gauge
Construction sets, HO-gauge
Tracks, HO-gauge M
Tracks, HO-gauge K
Signals, HO-gauge M
Signals, HO-gauge K + M
Catenary system, HO-gauge K + M
Bridges, HO-gauge
Turntables/locomotives roundhouses, HO-gauge
Grade crossings, HO-gauge
Locomotive accessories, HO-gauge
Lighting systems/station lighting, HO-gauge
Transformers, HO-gauge

18—77
18—21
22—23
24—27
28—29
30—45
35
74
46—52
53—57
58
59—62
64—65
63
66
68—69
70
71
72—73
74
75—76
77

Märklin-Sprint

80—85

Märklin "rak"

Miniature cars

86

**Märklin Metal
construction sets**

87—89

Märklin plus

90—97



Registered trade mark

It is not possible for deliveries to be made direct from the factory to private individuals. We reserve the right to introduce modifications and to amend the terms of delivery. The dimensions quoted are not guaranteed. This catalogue cancels all earlier issues.

All rights reserved · Reproduction in whole or in part forbidden · Printed in West Germany by Thiemig AG, Munich · 150 10—AA 06 75 th

Your local Märklin dealer:

The smallest series-produced electric railroad in the world

Scale 1:220

Märklin
mini-club



This shows "mini-club" in its actual size.

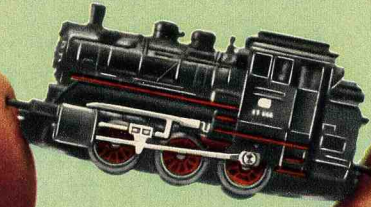

The maximum of pleasure in the minimum of space

Nothing like it has ever existed before. Never before has such a fascinatingly small and exciting genuine replica of the real thing been seen. This smallest series-produced electric railroad in the world has a gauge measuring all of $\frac{1}{64}$ " (6.5 mm); its double end locomotive is hardly longer than a match. Mini-club conjures up a magic world on your table, all in full view and within easy reach of your chair. You do not need a loft or a lot of floor space, you do not need to be a do-it-yourself expert. The mini-club is a true leisure time system which makes the most exciting of all hobbies into a portable leisure time game.

Märklin mini-club, the smallest series-produced electric railroad in the world, sets new, amazing standards. A model railroad "in your hand luggage" is no longer a dream. Even a teatray will do to serve up the magic of its remote-controlled models. Your hobby kit can now quickly be put away under the table, or brought out from the cupboard, or hung on the wall like a

picture. You can have ten minutes relaxation at any time just as easily as hours of pleasure in the evening, indoors, or on the porch or terrace, or in the home of friends. The handy portable model railroad has become a fact.

That is the most delightful aspect of this smallest series-produced railroad in the world. All the fuss and bother is reduced to a minimum. Mini-club is a game for lasting use, an absolute delight. Simply bring it out, connect it to the power supply and make complete escape the mini-club order of the day.

Mini-club locomotives should be operated only with a Märklin power pack 6711 or 6720-6731 (max. traction voltage 8 V).

An ideal suggestion right at the start

Märklin mini-club

Märklin mini-club Construction SET System

The first stage in this construction system is one of the S series gift sets (see page 6) with a **Freight train with power pack S 8905—8909** or an **Express train without power pack S 8902**. Each of these gift sets contain track sections to form a track oval.

new

mini-club SET

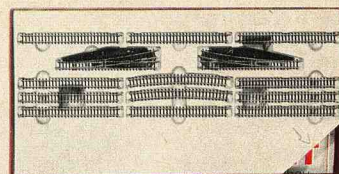

8190

Extension set E - Contents: 10 straight track sections 8500, 1 pair of manually operated turnouts 8564, 2 curved track sections 8591 and instructions for extending the layout

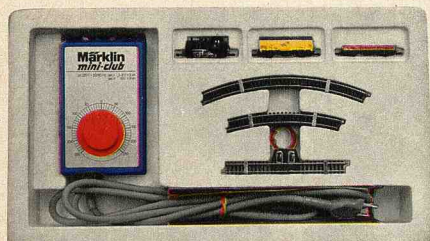

Freight train with power pack S 8905—8909

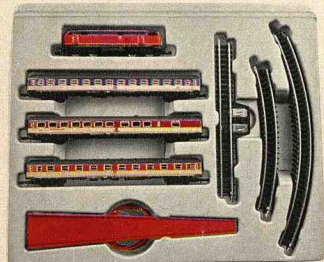
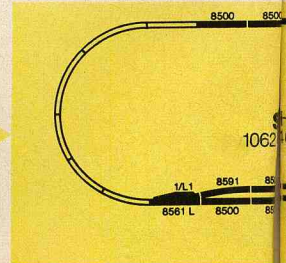
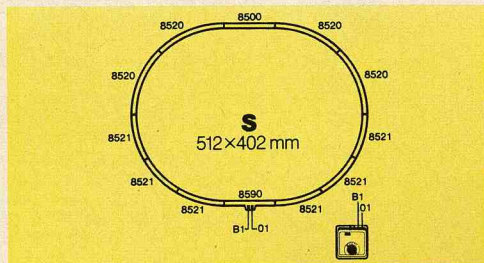

Express train without power pack S 8902

The first extension stage is an **Extension set E 8190** or an **Extension set E 8191**.

From here on, the following sets provide further extension to build up the ideal mini-club layout:

- Double track set T 1 8192**
- Station track set T 2 8193**
- Switching track set T 3 8194**

These three track sets T 1, T 2 and T 3 can be added in any order.

Construction of the ideal mini-club layout is very simple. Extensions are carried out in accordance with the instructions which are included with every set.

As soon as you have added Extension set E 8190 or E 8191, you can use the Toporama landscape 8930. This Toporama is highly recommended to add a further interest to the Märklin mini-club Construction SET System.

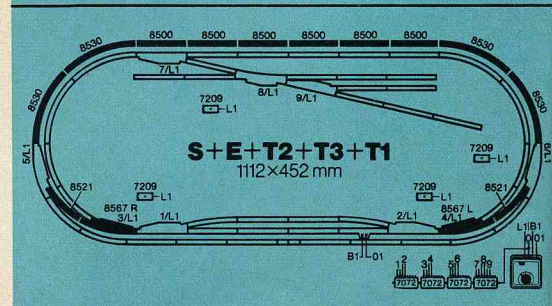
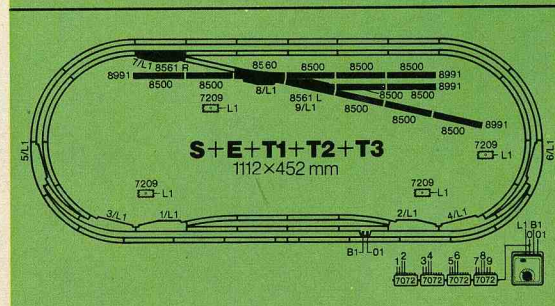
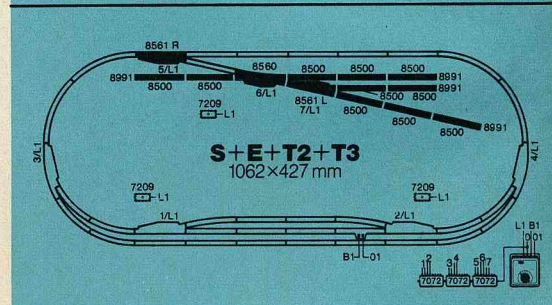
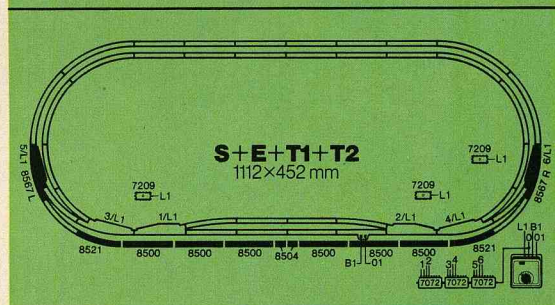
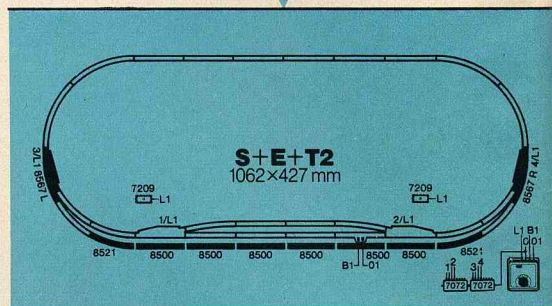
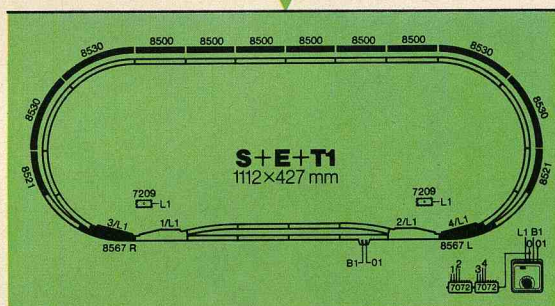

Märklin mini-club - The maximum of pleasure in the minimum of space

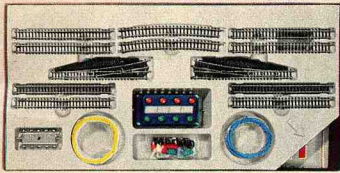

8191

Extension set E · Contents: 10 straight track sections 8500, 1 pair of solenoid-operated turnouts 8561, 2 curved track sections 8591, 1 turnout control panel 7072, 1 distributor plate 7209, with material for making connections, such as leads, sleeves and plugs · Instructions for extending the layout

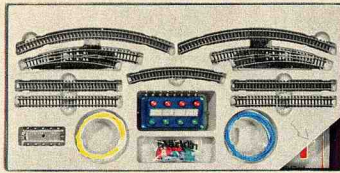

8192

Double track set T 1 · Contents: 6 straight track sections 8500, 2 curved track sections 8521, 4 curved track sections 8530, 1 pair of solenoid-operated turnouts 8567, 1 turnout control panel 7072, 1 distributor plate 7209, with material for making connections, such as leads, sleeves and plugs · Instructions for extending the layout

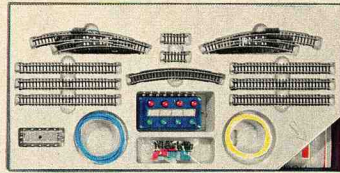

8193

Station track set T 2 · Contents: 6 straight track sections 8500, 2 straight track sections 8504, 2 curved track sections 8521, 1 pair of solenoid-operated turnouts 8567, 1 turnout control panel 7072, 1 distributor plate 7209, with material for making connections, such as leads, sleeves and plugs · Instructions for extending the layout

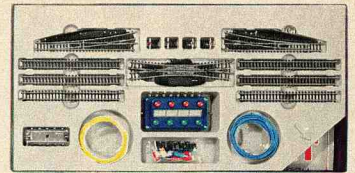

8194

Switching track set T 3 · Contents: 10 straight track sections 8500, 1 double slip 8560, 1 pair of solenoid-operated turnouts 8561, 4 buffer stops 8991, 1 turnout control panel 7072, 1 distributor plate 7209, with material for making connections, such as leads, sleeves and plugs · Instructions for extending the layout

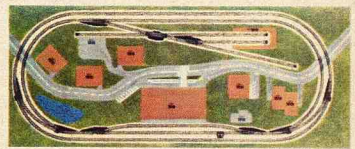
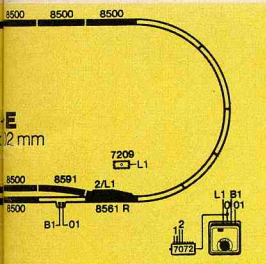

8930

Märklin mini-club Toporama for mini-club Construction SET System leading to the ideal track layout · Realistic printed model railroad landscape · Multicolour printing showing position of tracks · Can be used from stage E (8190, 8191) onwards · Tufted grass areas produce an effect of relief · Size 19 3/4" x 47 1/4" (50 x 120 cm)

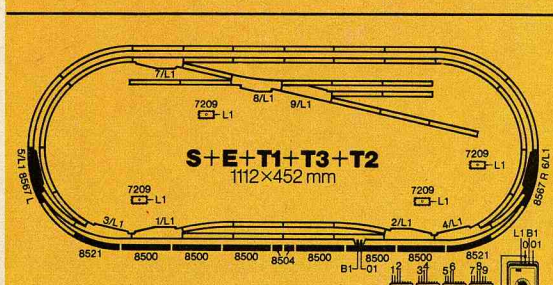
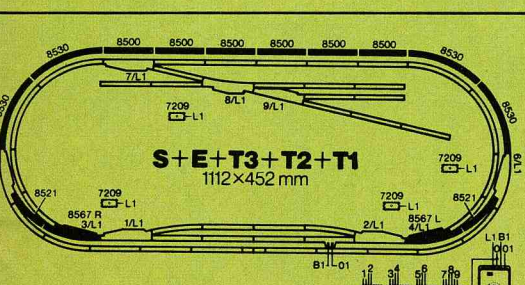
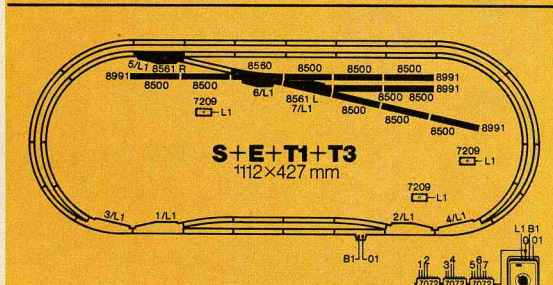
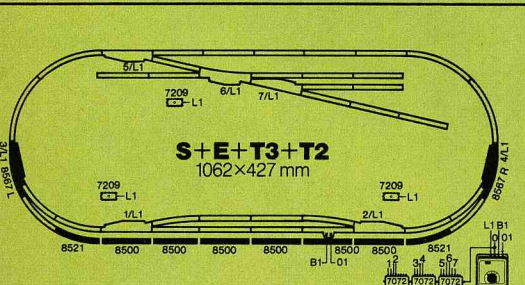
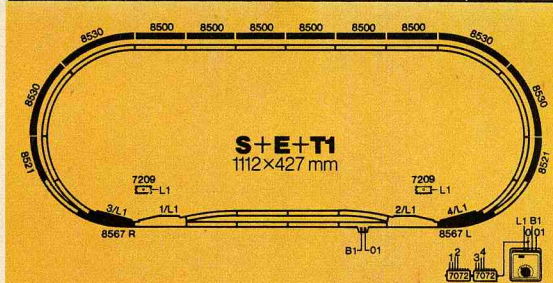
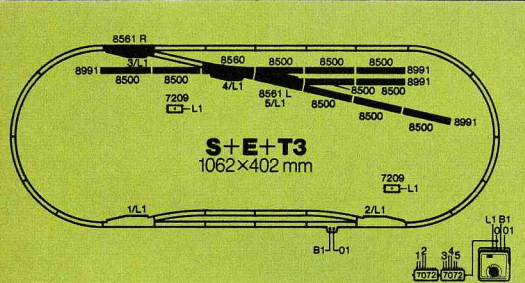

This is how to extend your layout, to a plan - every pack contains exactly what you need.

**Our suggestion:
Märklin mini-club
SET 123 with Topo-
rama landscape 8930**

(See page 4 for track plans)

This layout comprises Basic Set
S 8905—8909 or 8902,
Extension set **E** 8190 or **E** 8191,
Double track set **T** 1 8192,
Station track set **T** 2 8193,
Switching track set **T** 3 8194 and
Toporama 8930.



Section of the SET 123 layout

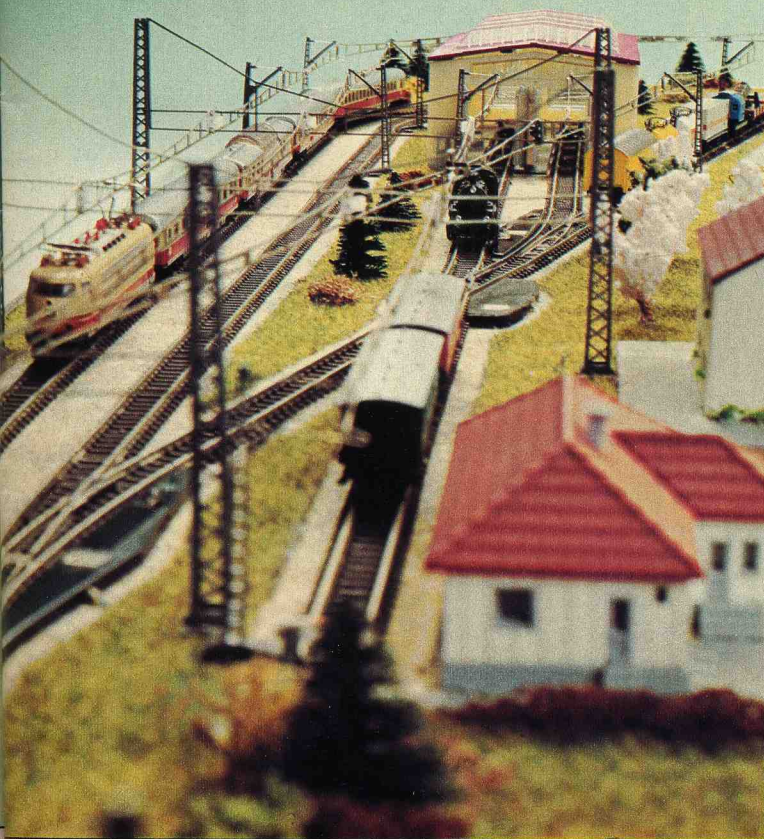

Section of the SET 123 layout

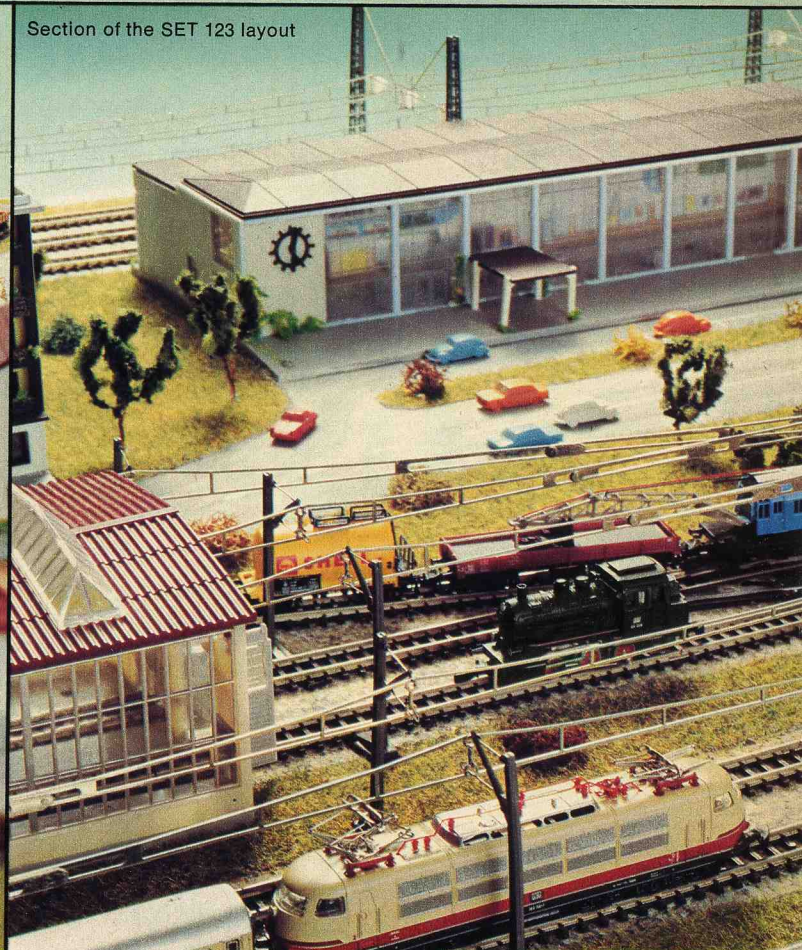

**With its great experience in model railroad construction
Märklin vouches for the quality of the smallest railroad.**

Train sets S for a good start

Märklin
mini-club

All you want to know at a glance

Märklin mini-club bears the gauge designation Z (6.5 mm = 17/64"). Märklin mini-club runs on DC power. Everything carrying the name mini-club is of the proven Märklin quality and is as hard-wearing, robust and reliable as every other model railroad made by Märklin.

The locomotives are fitted with suppressors, which, in conjunction with the suppressor elements incorporated in the Märklin power packs 6711 and 6720—6731 and in the feeder track sections 8590, ensure that the Regulations are complied with.

Mini-club locomotives should be operated only with a Märklin power pack 6711 or 6720—6731 (max. traction voltage 8 V).

8905 S 100 volt Japan

8907 S 110 volt USA

8908 S 240 volt Australia

8909 S 220 volt

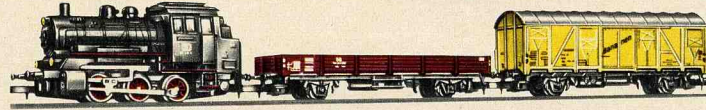

Freight train with power pack · With double end locomotive 8800, banana car 8606, gondola 8610, 1 straight track section 8500, 4 curved track sections

8520, 6 curved track sections 8521, feeder track section 8590 and power pack · Length of train 6 1/4" (160 mm)



The power pack of this basic set is not available on his own.

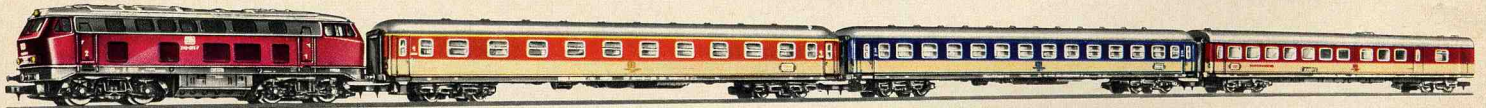

8902 S *new*

Express train (without power pack) · With diesel locomotive 8875, express coach 8720, express coach 8721, express diner car 8723, 1 straight track

section 8500, 4 curved track sections 8520, 6 curved track sections 8521, feeder track section 8590 and ramp 8974 · Length of train 17 1/2" (445 mm)

For train sets 8905—8909 and 8902 we recommend Märklin mini-club SET, the construction system leading to the ideal mini-club layout (see pages 2 and 3).

Märklin mini-club cars and wagons come in transparent packs. Make sure that the brand name "Märklin mini-club" is on the pack.

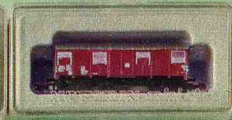

Märklin mini-club train sets and locomotives can be recognised by the club package with the characteristic teakwood pattern.



8800

Double end locomotive · A model of the 0-6-0 class 89 locomotive · 3 driven axles · Reversing by remote control · Mat black metal body · Die-cast zinc frame · Automatic coupling at each end · Length over buffers 1 7/8" (45 mm)

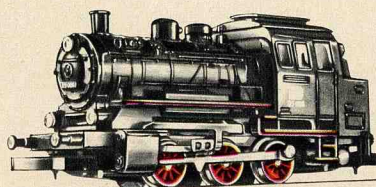

8864

Diesel locomotive · A model of the German Federal Railways' 0-6-0 locomotive of Class 260 · 3 driven axles · Reversing by remote control · Red metal body · Silver-colored roof · Die-cast zinc frame · Automatic coupling at each end · Length over buffers 2" (49 mm)

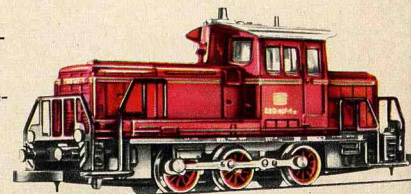

The smallest series-produced railroad in the world

8803

Passenger train locomotive with tender · A model of the 2-6-0 German Federal Railways' class 24 · 3 driven axles · Reversing by remote control · Arranged for the fitting of lighting insert 8953 for three headlights · Mat black metal body · Die-cast zinc

frame · Automatic coupling on the tender · Length over buffers 3 $\frac{1}{4}$ " (82 mm)

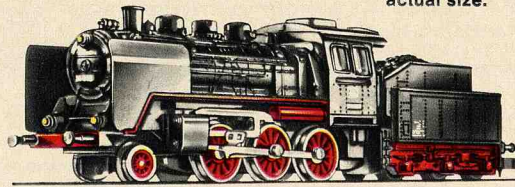

The pictures show the various locomotives, coaches and wagons in their actual size.

8885

Express train locomotive with tender · A model of the German Federal Railways' 4-6-2 locomotive of Class 003 · 3 driven axles · Reversing by remote control · Three working headlights · Mat black metal body · Die-cast zinc

frame · Automatic coupling on the tender · Length over buffers 4 $\frac{3}{4}$ " (112 mm)

☏ = 8953

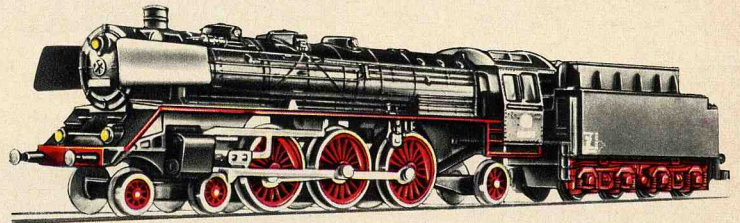

8827 **new**

Freight train locomotive with tender · A model of the German Federal Railways' 2-8-2 locomotive of Class 41 · 4 driven axles · Reversing by remote control · Three working headlights · Mat black metal body · Die-cast zinc

frame · Automatic coupling on the tender · Length over buffers 4 $\frac{3}{4}$ " (112 mm)

☏ = 8953

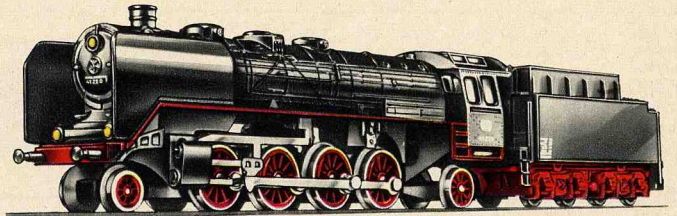

8854

Electric express locomotive · A model of the German Federal Railways' 0-6-6-0 locomotive of Class 103 · Both bogies driven · Reversing by remote control · Three working headlights at each end, changing over with change in direction · Plastic body in the TEE colours beige and red · Aluminium-colored roof superstructure · Windows

inset in plastic frames · 2 spring-loaded pantographs on roof · Switch lever for selecting operation from overhead wire or the track contacts · Die-cast zinc frame · Automatic coupling at each end · Length over buffers 3 $\frac{1}{2}$ " (88 mm)

☏ = 8953

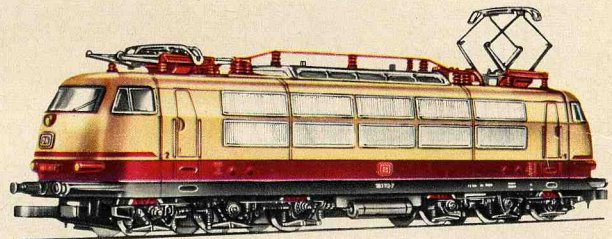

8857 **new**

Electric freight locomotive · A model of the German Federal Railways' 0-6-6-0 locomotive of Class 151 · Both bogies driven · Reversing by remote control · Three working headlights at each end, changing over with change in direction · Green plastic body · Windows inset in plastic frames · 2 spring-loaded pantographs on roof ·

Switch for selecting operation from overhead line or the track contacts · Die-cast zinc frame · Automatic coupling at each end · Length over buffers 3 $\frac{1}{2}$ " (88 mm)

☏ = 8953

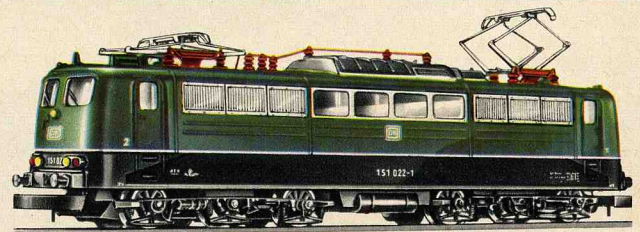

8875

Diesel locomotive · A model of the German Federal Railways' 4-4 locomotive of Class 216 · All axles driven · Reversing by remote control · Three working headlights at each end, changing over with change in direction · Red and grey plastic body ·

Die-cast zinc frame · Automatic coupling at each end · Length over buffers 3" (75 mm)

☏ = 8953

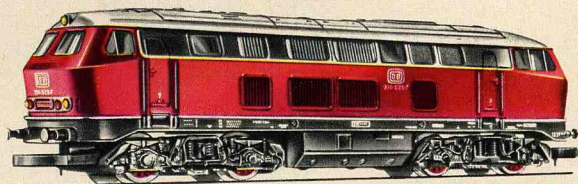

8816

Railbus · A model of the German Federal Railways' type 798 · Both axles driven · Reversing by remote control · Three working headlights at each end · Red plastic body · Die-cast zinc frame · Length over buffers 2 $\frac{3}{8}$ " (62 mm)

☏ = 8953

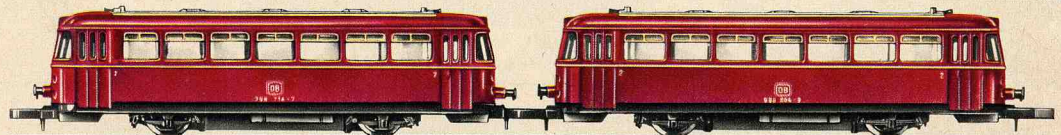

8817

Trailer for railbus · A model of the German Federal Railways' type 998 · Three working headlights at each end ·

Red plastic body · Die-cast zinc frame · Length over buffers 2 $\frac{3}{8}$ " (62 mm)

☏ = 8953

If the train comprises more than one trailer, a further motorised unit must be used.

Style and perfection cause never ending delight.

8710

Express coach · 1st class · A model of the German Federal Railways' Coach type A üm · Windows inset in plastic frames · Length 47/8" (120 mm)



8711

Express coach · 2nd class · A model of the German Federal Railways' Coach type B üm · Windows inset in plastic frames · Length 47/8" (120 mm)

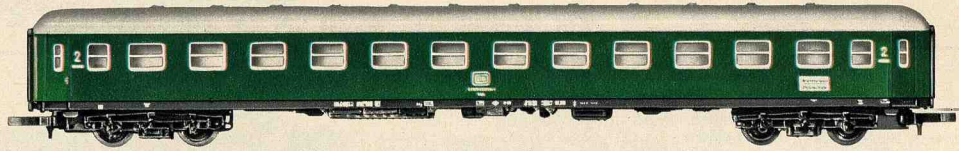

8712

Express baggage car · A model of the German Federal Railways' car type D üm · Windows inset in plastic frames · Length 47/8" (120 mm)



8713

Express dining car · A model of the German Federal Railways' car WR üm · Windows inset in plastic frames · Length 47/8" (120 mm)

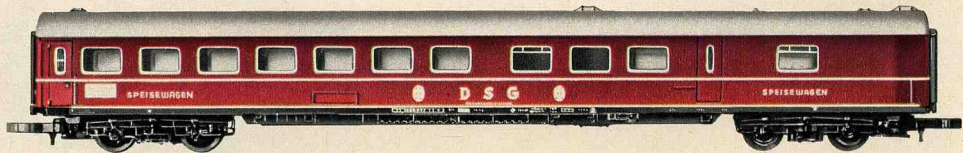

8720

Express coach · 1st class · A model of the German Federal Railways' coach type A üm · Windows inset in plastic frames · Length 47/8" (120 mm)



8721

Express coach · 2nd class · A model of the German Federal Railways' coach type B üm · Windows inset in plastic frames · Length 47/8" (120 mm)



8722

Express baggage car · A model of the German Federal Railways' car type D üm · Windows inset in plastic frames · Length 47/8" (120 mm)



8723

Express dining car · A model of the German Federal Railways' car type WR üm · Windows inset in plastic frames · Length 47/8" (120 mm)

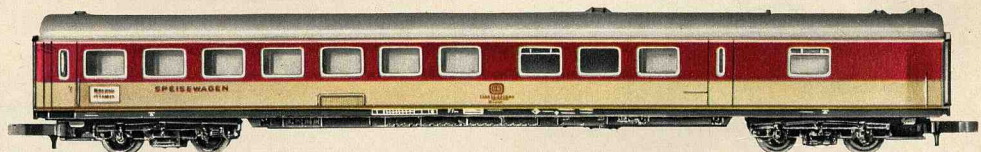

8700

Passenger coach · Platform and entrance at each end · Windows with plastic panes · Length 23/8" (60 mm)

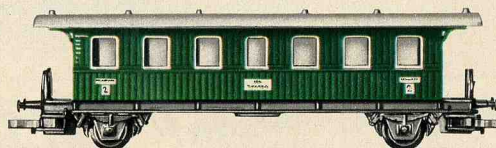

8701

Passenger coach · Platform and entrance at each end · Windows with plastic panes · Length 23/8" (60 mm)

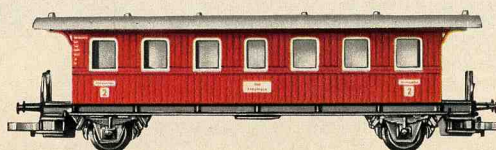

Realistic effect produced by precision workmanship

8724

TEE compartment coach · 1st class · A model of the German Federal Railways' coach type Avm · Windows inset in plastic frames · Length 47 1/8" (120 mm)

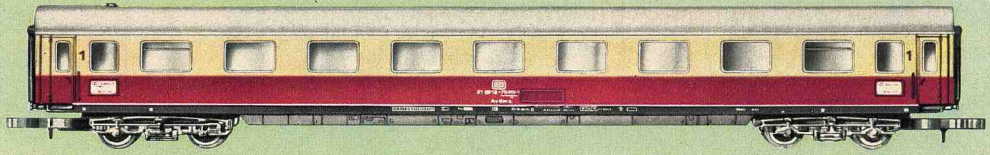

8725

TEE open-plan coach · 1st class · A model of the German Federal Railways' coach type Apm · Windows inset in plastic frames · Length 47 1/8" (120 mm)

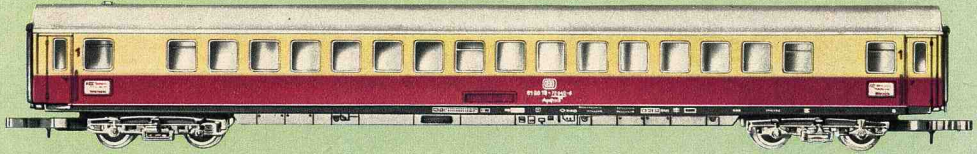

8726

TEE dining car · A model of the German Federal Railways' car type WRm · Windows inset in plastic frames · Length 47 1/8" (120 mm)

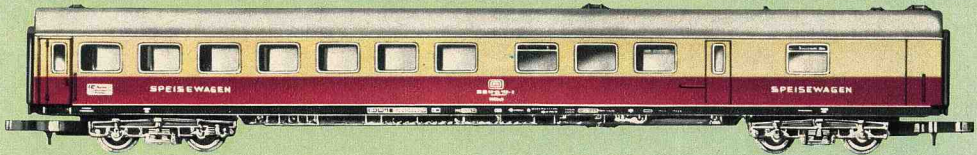

8728 **new**

TEE dome car · 1st class · A model of the German Federal Railways' car type ADm · Windows inset in plastic frames · Clear plastic observation dome · Length 47 1/8" (120 mm)

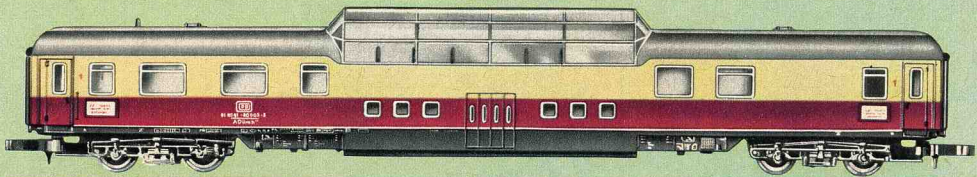

Into mini-club-land on the Trans-Europa-Express.
In the dome coach of course.

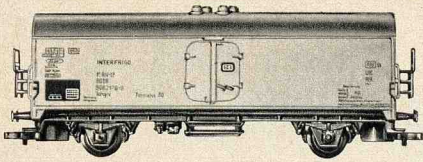

8600

Refrigerated car · A model of the German Federal Railways' car, type lchqrs · Length 2 1/8" (54 mm)



8601

Beer car · A model of a car privately owned by the Dortmund Union Brewery · Length 2 1/8" (54 mm)

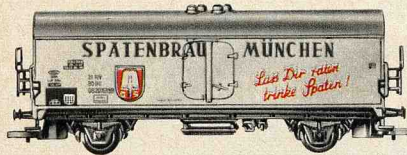

8602

Beer car · A model of a car privately owned by the "Spatenbräu" Brewery, Munich · Length 2 1/8" (54 mm)



8603

Beer car · A model of a car privately owned by the Kulmbacher Mönchshof Brewery · Length 2 1/8" (54 mm)



8604 **new**

Beer car · A model of a car privately owned by the Kulmbacher Reichelbräu Brewery · Length 2 1/8" (54 mm)

8620

Well wagon · With transformer as load · Length 6" (154 mm)



8621 **new**

Crane car with slewing crane, movable boom and boom support · Crane hook can be raised and lowered by hand crank · Length of underframe 1 3/8" (35 mm) · (Gondola 8610 not included in the price but is recommended for moving the crane car)

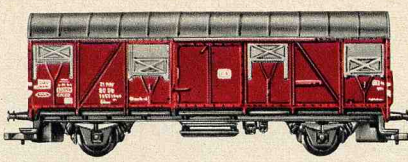

8605

Box car · A model of the German Federal Railways' type Gbrs · Length 2 1/8" (54 mm)

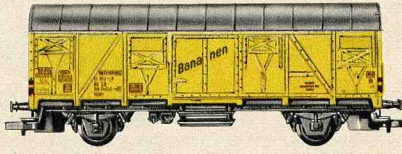

8606

Box car · A model of the German Federal Railways' type lbbls · Length 2 1/8" (54 mm)

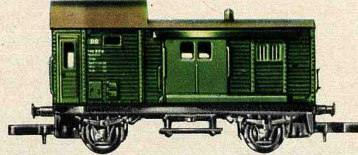

8609

Freight train baggage car · A model of the German Federal Railways' type Dg · Working doors on each side · Length 1 3/8" (40 mm)



8610

Gondola · Length 2 1/8" (54 mm)



8611

Tank car · SHELL · Length 1 3/8" (40 mm)

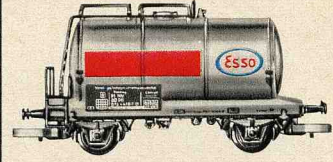

8612

Tank car · ESSO · Length 1 3/8" (40 mm)



8613

Tank car · ARAL · Length 1 3/8" (40 mm)

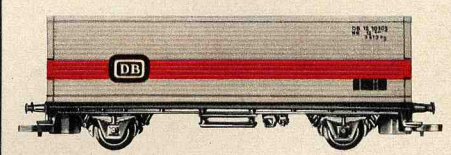

8615

Container car · German Federal Railways' · Length 2 1/8" (54 mm)



8616

Container car · Sealand · Length 2 1/8" (54 mm)

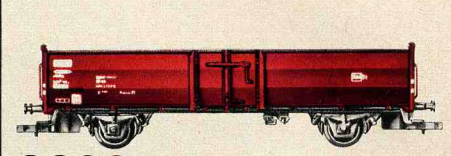

8622

Open freight car · A model of the German Federal Railways' type 0mm 52 · Length 2 1/8" (54 mm)

That these delightful little trains work just like the real trains on which they are modelled, makes Märklin mini-club so fascinating.

Examples of layout construction from booklet 0291

1 Layout

37 1/2" x 16 3/4"

(952 x 427 mm)

Recommended base size 39 1/2" x 19 3/4"

(1000 x 500 mm)

- | | | |
|--------|---------|---------|
| 1-8500 | 3-7000 | 1-6731 |
| 4-8504 | 1-7100 | or 6711 |
| 9-8505 | 2-7101 | |
| 5-8520 | 2-7102 | 8960 |
| 8-8521 | 1-7103 | 8962 |
| 2-8561 | 2-7105 | 8964 |
| 1-8567 | 2-7111 | 8965 |
| 1-8590 | 7-7112 | 8950 |
| 1-8597 | 10-7113 | |
| 3-8598 | 11-7115 | |
| 3-8939 | 7-7117 | |
| 3-8946 | 2-7131 | |
| 4-8991 | 7-7132 | |
| | 10-7133 | |
| 2-7072 | 11-7135 | |
| 3-7209 | 7-7137 | |
| | 1-8951 | |

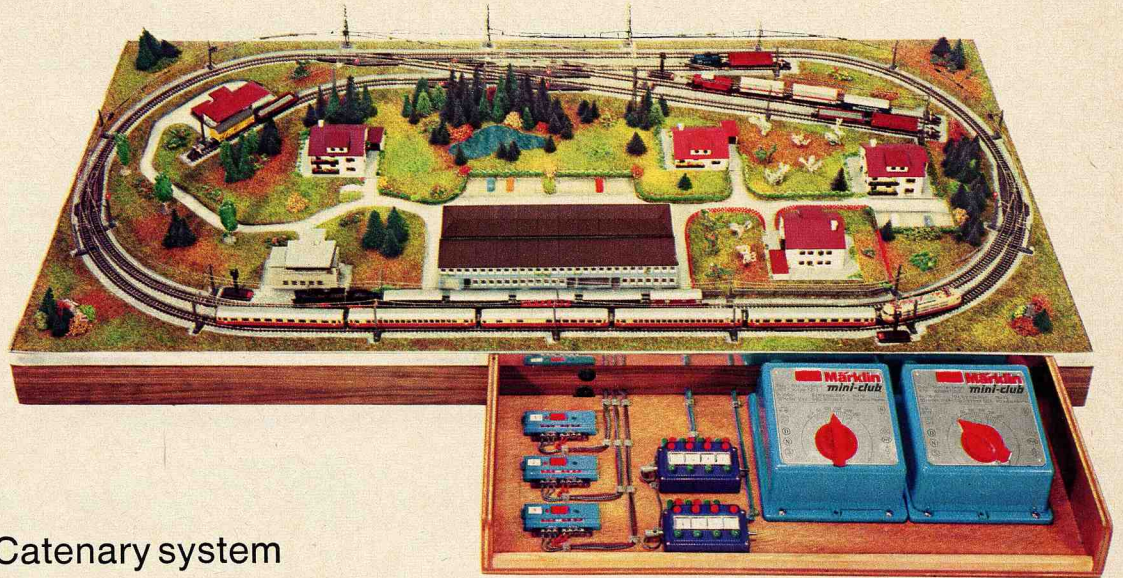

Catenary system

- | | |
|---------|---------|
| 24-8911 | 3-8924 |
| 1-8912 | 2-8921 |
| 6-8914 | 1-8926 |
| 19-8922 | 1-6731 |
| 18-8923 | or 6711 |

4 Layout

48" x 22 1/2"

(1222 x 572 mm)

Recommended base size 49 1/4" x 24"

(1250 x 610 mm)

- | | | |
|---------|---------|---------|
| 15-8500 | 3-7072 | 2-6731 |
| 8-8504 | 3-7209 | or 6711 |
| 11-8505 | 1-7210 | |
| 10-8510 | 2-7000 | 8960 |
| 4-8520 | 1-7100 | 8963 |
| 3-8521 | 2-7101 | 8964 |
| 2-8530 | 1-7102 | 8965 |
| 1-8531 | 1-7103 | 8966 |
| 4-8561 | 2-7105 | 8950 |
| 1-8567 | 2-7111 | |
| 2-8590 | 10-7112 | |
| 2-8591 | 17-7113 | |
| 4-8592 | 16-7115 | |
| 2-8597 | 4-7117 | |
| 9-8598 | 2-7131 | |
| 3-8939 | 10-7132 | |
| 3-8946 | 17-7133 | |
| 7-8976 | 16-7135 | |
| 2-8977 | 4-7137 | |
| 2-8978 | 1-8951 | |
| 2-8991 | | |



0208

Track planning pattern for Märklin mini-club tracks. All the track sections are cut out in the pattern to a scale of 1:5 and can easily be transferred on to paper with a pencil

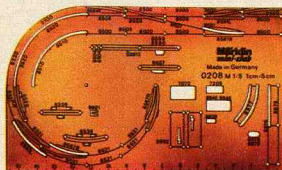

0291

"Märklin mini-club Track Layouts" booklet. Illustrated instructions for building of 16 track layouts and catenary systems, connecting up power packs and solenoid-operated items and for building bridges. Contents 54 pages. Size 8 1/4" x 11 3/4" (21 x 30 cm). English text



This smallest of railroads is capable of everything the big ones can do

With a gauge of $\frac{17}{64}$ " (6.5 mm) the overall width of the mini-club track sections is about $\frac{1}{16}$ " (11.5 mm) and the height $\frac{1}{10}$ " (2.5 mm). The silver-colored solid section rails are arranged on a plastic tie strip. The rails are connected by means of the same type of rail joiners as used with the bigger models. An additional clip fixed to the tie strips increases the strength of the track joints.

This drawing shows 3 Märklin mini-club track circles with their radii, track spacings and angles.

- 1 circle 8510 = 8 track sections
- 1 circle 8520 = 8 track sections
- 1 circle 8530 = 8 track sections

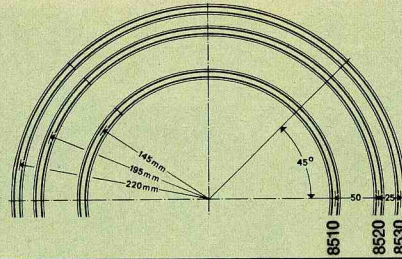

Straight track sections

8500

Length $4\frac{3}{8}$ " (110 mm)

8504

Length 1" (25 mm)

8505

Length $8\frac{5}{8}$ " (220 mm)

8506

Length $4\frac{3}{16}$ " (108.6 mm)

see Fig. 2, page 13

8507

Length $4\frac{1}{2}$ " (112.8 mm)

see Fig. 4, page 13

Curved track sections

8510

Radius $5\frac{3}{4}$ " (145 mm) · 45°

8530

Radius $8\frac{5}{8}$ " (220 mm) · 45°

8520

Radius $7\frac{3}{4}$ " (195 mm) · 45°

8531

Radius $8\frac{5}{8}$ " (220 mm) · 30°

8521

Radius $7\frac{3}{4}$ " (195 mm) · 30°

8591

Radius $19\frac{9}{16}$ " (490 mm) · 13°

Corresponds to the curve of turnouts 8561 and 8564 (see Fig. 3, page 13)

Functional tracks

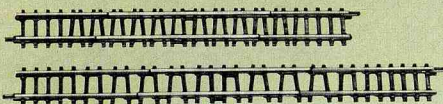

8592

Track section, straight · For making up track to required length · Extendable from 4" (100 mm) to $4\frac{3}{4}$ " (120 mm)

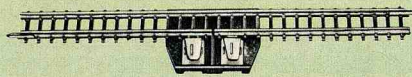

8598

Insulating track section, straight · With terminals · The rail nearer the terminals is interrupted at the centre · Length $4\frac{3}{8}$ " (110 mm)

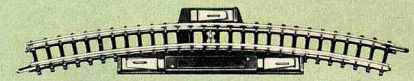

8529

Switching track section, curved · With terminals · The passing train actuates electrical switching operations · Radius $7\frac{3}{4}$ " (195 mm) · 30°



8590

Feeder track section, straight · Fitted with suppressor · 2 terminals for connection to track power leads, which are included · Length $4\frac{3}{8}$ " (110 mm)

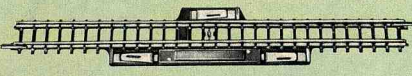

8599

Switching track section, straight · With terminals · The passing train actuates electrical switching operations · Length $4\frac{3}{8}$ " (110 mm)



8539

Switching track section, curved · Construction and operation as for 8529 but radius $8\frac{5}{8}$ " (220 mm) · 30°

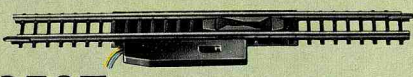

8597

Uncoupling track section · For releasing automatic couplings · Operated either remotely by means of the electromagnets incorporated, or by hand lever · Length $4\frac{3}{8}$ " (110 mm)

The switching track sections 8529, 8539 and 8599 enable the moving train to control solenoid-operated items automatically. Actuated by the locomotive moving in either direction, they can perform various switching operations independently of one another. The control pulses are drawn from two terminals electrically separated from one another.

Märklin mini-club is small, but developed to perfection

Crossings and turnouts

8559

Crossing · Crossing angle 13° · Length of track sections 4 1/2" (112.8 mm) · (See Fig. 1)

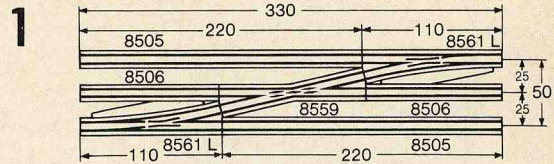
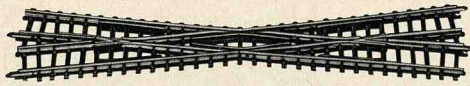

8560 **new**

Double slip · Crossing angle 13° · Radius 12 3/4" (323 mm) · The slip points, which are on the inside, are remotely operated through double solenoids · Additional manual switching lever · Length of the straight track sections 4 1/2" (112.8 mm) · (See Fig. 2 for an example of its installation)

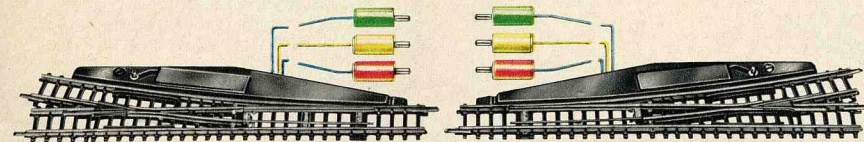
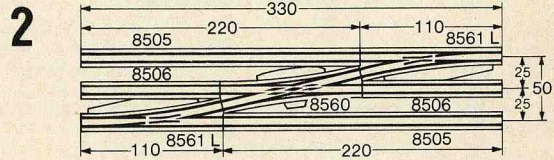
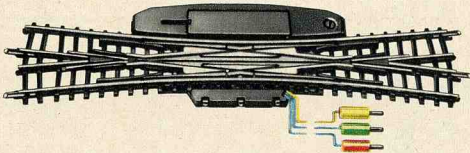

8561

Pair of solenoid-operated turnouts · Comprising one right-hand and one left-hand turnout, each operated by double solenoid · Additional manual

switching lever · Turnout angle 13° · Radius of the branch tracks 19 5/16" (490 mm) · Length of the straight track section 4 3/8" (110 mm) · (See Fig. 3 and 4 for example of its installation)

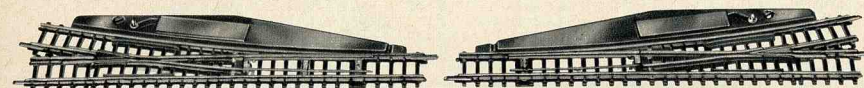
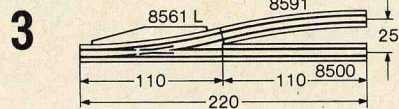

8564

Pair of manually operated turnouts · Comprising one right-hand and one left-hand turnout · Operated by hand

lever · Turnout angle 13° · Radius of the branch track 19 5/16" (490 mm) · Length of the straight track section 4 3/8" (110 mm) · (See Fig. 3 and 4 for an example of its installation)

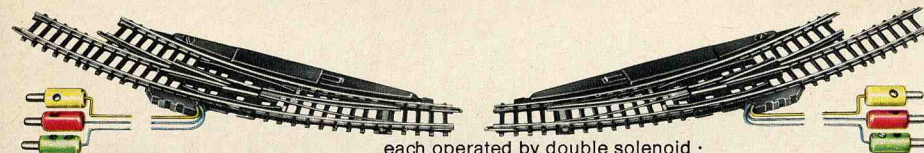
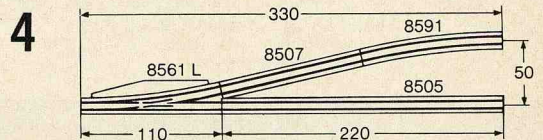

8567

Pair of curved solenoid-operated turnouts · Comprising one right-hand and one left-hand inner circle turnouts,

each operated by double solenoid · Additional switching levers for manual operation · Length and radius of the branch track as for track section 8521 · Length of the main track 4 7/8" (125 mm) · (See Fig. 5 for an example of its installation)

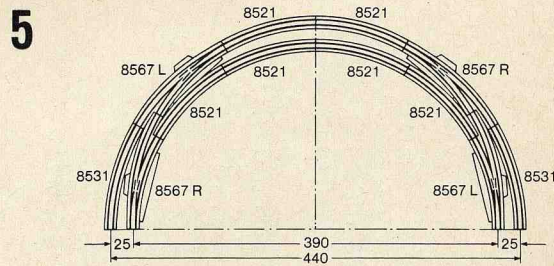

Track accessories

8951

Pack of 10 insulating links · Made of plastic · For electrically isolating lengths of track

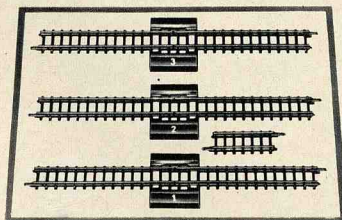

8991

Buffer stop · Clips over the rails · Black · Buffer beam white with red stripe · Length 5/8" (15 mm)



8993

Reversing loop kit · Consisting of 3 track sections, which are arranged one following the other as marked, and 1 track section 8504 · Allows one-way travel over reversing loops

8999

Track fixing nails · 1/4" long (0.5 x 6 mm) · Pack of 100 nails



Robust and reliable, because it's Märklin

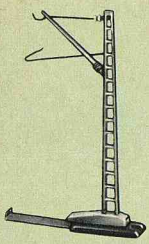

8911

Mast for overhead line · Basic element with support plate · Height 1½" (38 mm)

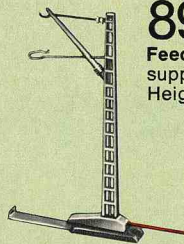

8912

Feeder mast for power supply · With support plate and connection lead · Height 1½" (38 mm)



8913

Bridge mast for clipping on to the side of bridges or ramp sections · Height 1½" (41 mm)

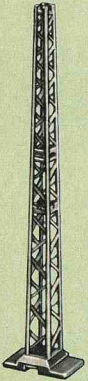

8914

Tower mast with recesses to support cross spans 8924 and 8925 · Base ¼" × ½" (7 × 13 mm) · Height 2¾" (61 mm)

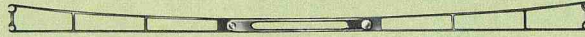

8923

Contact line section · Length adjustable between 5⅞" and 7⅞" (150—180 mm)

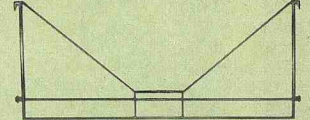

8925

Cross span · For hooking into tower masts · Spans 3 tracks · Span 2⅞" approx. (72 mm approx.)

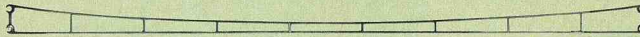

8922

Contact line section for straight and curved tracks · Length 6½" (165 mm)

8924

Cross span · For hooking into tower masts · Spans 5 tracks · Span 4¾" approx. (123 mm approx.)

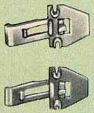
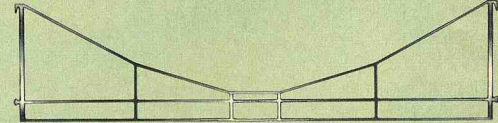

8921

Contact line insulator pack · For insulating contact line section from cross spans · Includes white and grey insulators · The white insulators will hold two contact wire sections, the grey ones three sections

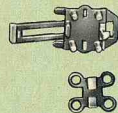

8926

Pack of insulating sections and connection springs · Are required to set up isolating points in the overhead conductor and at branches over turn-outs

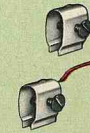

8927

Pack of contact wire terminals · Contains screw terminals with and without leads · For feeding power into catenary sections or to hold together contact line sections, e.g. over crossings

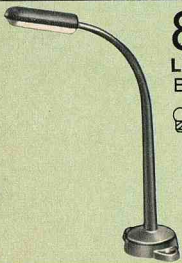

8957 **new**

Lamp standard · Height 1¾" (46 mm) · Base ¼" × ½" (8 × 14 mm)

⚡ = 60210



8958 **new**

Station lamp standard · Height 1¾" (46 mm) · Base ¼" × ½" (8 × 14 mm)

⚡ = 60210



8959 **new**

Sidewalk lamp standard · Height 1" (25 mm) · Base ¼" × ½" (8 × 14 mm)

⚡ = 60210



Everything for building a layout - including lighting and catenary system naturally.

6711 220 volt

Märklin mini-club power pack for AC power supply · One-knob control for adjusting the **traction voltage (DC)** between 0 and 8 V and determining the direction of travel by turning clockwise or anticlockwise from its central position · Power output in the traction circuit up to 8 VA, in the **lighting circuit (AC)** 12 VA approx. at 10 V · Blue plastic case · Weight 3 lb 10 oz (1.65 kg) · Dimensions 6¹/₈" × 4⁵/₁₆" × 3¹/₂" (155 × 110 × 88 mm)

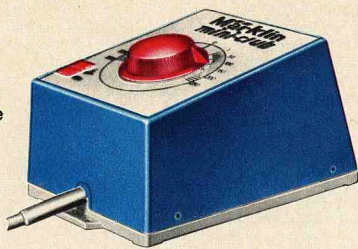

6720 100 volt Japan

6726 110 volt

6727 110 volt USA

6729 240 volt England

6731 220 volt

Märklin mini-club power pack for AC power supply · Output 12 VA · **Traction voltage (DC)** adjustable between 2 V and 8 V · Pole changing switch for selecting the direction of travel ·

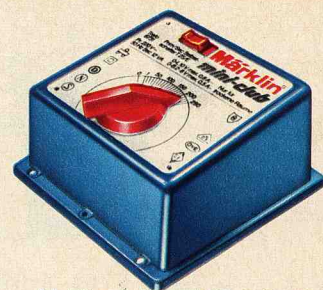

Lighting voltage (AC) 10 V · Blue plastic case · Weight 2 lb 11 oz (1.2 kg) · Dimensions 5" × 5³/₈" × 3" (125 × 135 × 75 mm)

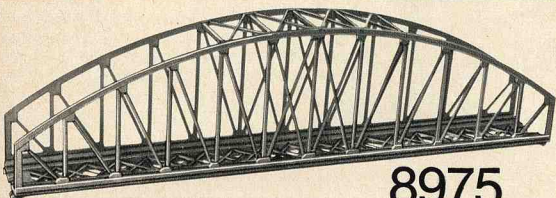

8975

Arch bridge · Made of plastic · Grey · Length 8⁷/₈" (220 mm)

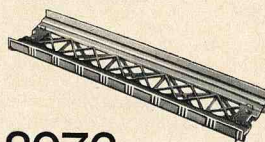

8976

Ramp section, straight · Length 4³/₈" (110 mm)



8977

Ramp section, curved · Radius 5³/₄" (145 mm) · Track curve 45°

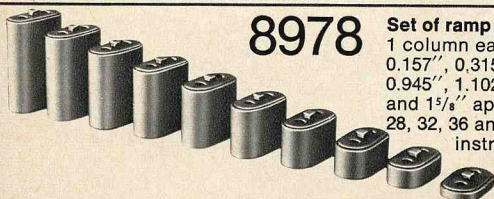

8978

Set of ramp columns · Comprising 1 column each of the following heights 0.157", 0.315", 0.472", 0.630", 0.787", 0.945", 1.102", 1.260", 1.417", 1.575" and 1⁷/₈" approx. (4, 8, 12, 16, 20, 24, 28, 32, 36 and 40 mm) · Installation instructions are included



8979

Set of bridge columns · Comprising 5 columns 1⁵/₈" high (40 mm)



A proper railroad layout naturally has bridges – Märklin mini-club too!

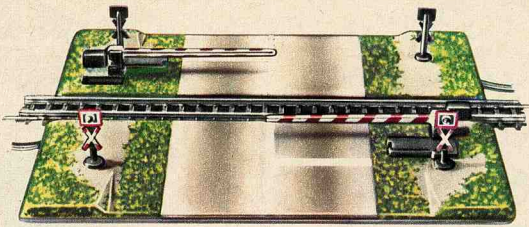

8992

Grade crossing with half barriers · Comprising two solenoid-controlled barriers, each with 2 red warning lights which light when the barrier is closed · Size of each base $3\frac{3}{4}'' \times 1\frac{1}{2}''$ (96×37 mm) · (The track sections shown in the illustration are not included in the price and are not supplied with the grade crossing)

⚡ = 8953

The following are also required for the grade crossing:

- a) for **manual** operation: 1 signal manual switch 8946
- b) for **automatic** operation by the moving train: 1 universal remote-control switch 8945
- 2 switching track sections (e.g. 8599, 8529 or 8539 depending on the track layout)

The various possible ways of incorporating the grade crossing into the system are explained in the operating instructions supplied with it.

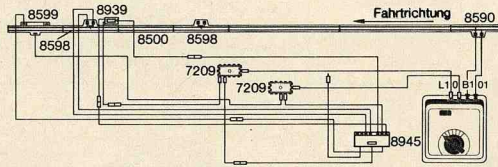
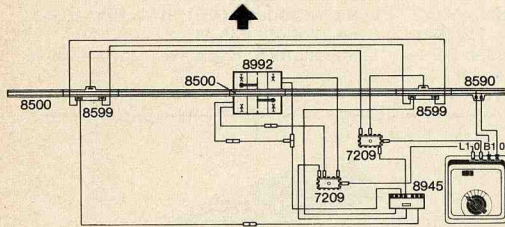

Arrangement of signal 8939 and a switching track section, on "stop".

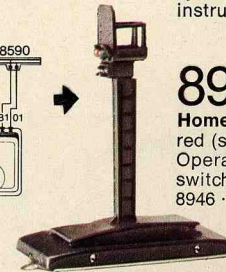

8939

Home light signal · Light changes from red (stop) to green (go) · 2 light bulbs · Operated by a universal remote-control switch 8945 or by signal manual switch 8946 · Height $1\frac{3}{8}''$ (34.5 mm)

⚡ = 8953

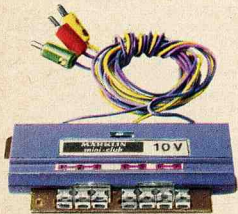

8945

Universal remote-control switch with 2 single-pole switches and a change-over switch for various circuits · The universal remote-control switch can be given a variety of functions to perform (up to 3 simultaneously) and it will perform them automatically · Examples of applications are shown in the brochure 0291 (see page 11) and in the Märklin mini-club guide · Operating voltage 10 V · Double-solenoid operation · Can be operated by a switching track section, from a turnout control panel or by means of the manual switching lever · Width $1\frac{3}{16}''$ (30 mm) · Length $2\frac{3}{4}''$ (70 mm) · Height $\frac{1}{4}''$ (8 mm)

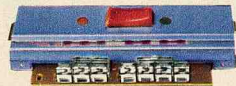

8946

Signal control panel with 2 single pole switches and 1 reversing switch, for example to control signal 8939 and locomotive power · Width $1\frac{3}{16}''$ (30 mm) · Length $2\frac{3}{4}''$ (70 mm) · Height $\frac{1}{4}''$ (8 mm)



8973

Pack containing various miniature automobiles

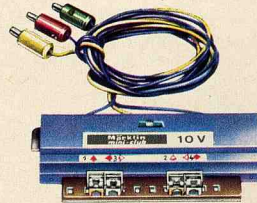

8947 **new**

Double-pole change-over switch (pole reversing switch) · Operating voltage 10 V · Double solenoid operation · Operated by a switching track section, from a turnout control panel or by manual switching lever · Width $1\frac{3}{16}''$ (30 mm) · Length $2\frac{3}{4}''$ (70 mm) · Height $\frac{1}{4}''$ (8 mm)

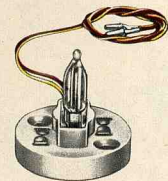

8950

Light socket with lamp insert and lead · For stations, buildings and the like

⚡ = 8953



8974

Ramp · Made of plastic · Facilitates placing locomotives or cars on the track · Length $5\frac{1}{2}''$ (140 mm) · Height $\frac{1}{2}''$ (13.5 mm)



8953

Light insert · With 10 V bulb · For use with light socket 8950, signal 8939, grade crossing 8992 and in locomotives arranged to take lighting

8987

Pair of motor brushes for locomotives 8800, 8803 and 8864

8988

Pair of motor brushes for locomotives 8816, 8854, 8857 and 8875

8989

Pair of motor brushes for locomotives 8827 and 8885

8960

Construction kit, Göppingen station · Modern design · Base area $9'' \times 4\frac{1}{2}''$ (228×114 mm) · Height $1\frac{1}{8}''$ (44 mm) · Arranged to take light socket 8950

8961

Construction kit, platform · In 2 sections · Overall length $17\frac{3}{8}''$ (440 mm) · Width $1\frac{1}{2}''$ (38 mm) · Height $1''$ (23 mm)

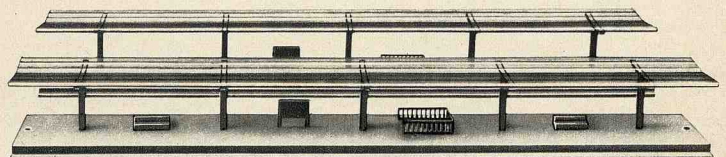
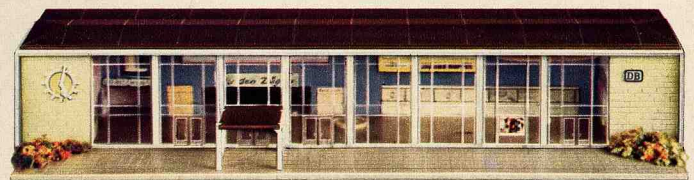

Märklin mini-club is small, but developed to perfection.



8962

Construction kit, Dürnau station · Multipurpose building with annex and loading ramp · Base area $2\frac{3}{4}'' \times 2''$ (70×50 mm) · Height $1\frac{1}{4}''$ (30 mm) · Arranged to take light socket 8950

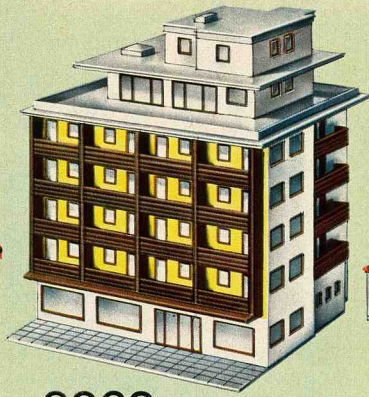

8963

Construction kit, multistorey building with penthouse · The two top sections can also be used separately as a bungalow or kiosk · Base area $3\frac{3}{8}'' \times 3\frac{1}{4}''$ (86×84 mm) · Height $3\frac{3}{4}''$ (97 mm) · Arranged to take light socket 8950

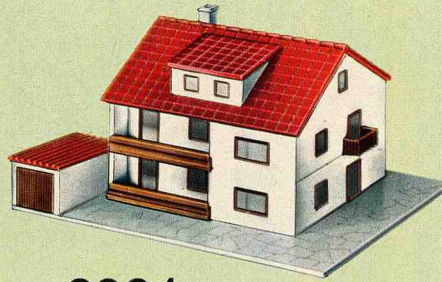

8964

Construction kit, dwelling house with garage, usable as one or two storeys · Base area $3\frac{1}{2}'' \times 2\frac{3}{4}''$ (91×71 mm) · Height $1\frac{3}{4}''$ (45 mm) · Arranged to take light socket 8950



8965

Construction kit, signal box · Base area $2\frac{3}{4}'' \times 1\frac{1}{2}''$ (69×39 mm) · Height $1\frac{3}{4}''$ (46 mm) · Arranged to take light socket 8950

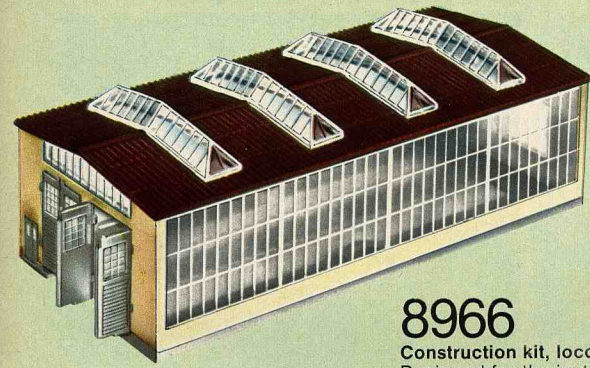

8966

Construction kit, locomotive shed · Designed for the installation of 2 locomotive stabling sidings and catenary system · Length $6''$ (152 mm) · Width $2\frac{7}{8}''$ (74 mm) · Height $2''$ (51 mm)

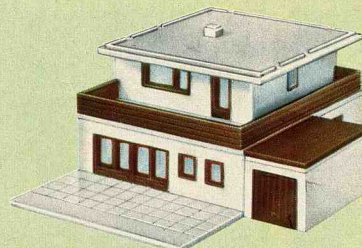

8968 new

Construction kit, terrace house with garage · White · Can be built as one or two-storied in a number of variants, or can be used as a terraced house · Base area $3\frac{1}{8}'' \times 1\frac{3}{4}''$ (81×45 mm) · Height $1\frac{1}{8}''$ (29 mm) · Arranged to take light socket 8950



8969 new

Construction kit, terrace house with garage · Similar to construction kit 8968 but with pale blue wall sections

0299 new

Brochure "From Kiosk to Skyscraper" · Illustrated instructions on the many ways of using construction kits 8968 and 8969



Out of the construction kits arise houses and railroad buildings – on the mini-club scale of 1:220 of course.

All the information given here on the HO model railroad will be of interest to you.

(Even if you already have one.)

Irrespective of whether your Märklin HO model railroad layout is large or small, there is always scope for new developments, extensions and improvements. Yet each stage is complete in itself and deeply satisfying. From the first single little train in a setting of toddler's toys and boxes, up to the extensive layout of the enthusiast, equipped by using all of Märklin's ingenious techniques, in all cases the whole of the small or simple layout can be fully integrated into the bigger or more elaborate layout, with nothing left over unused. A model railroad offers infinite possibilities as a hobby, giving a chance to plan, design, invent and do-it-yourself, so that at any age, whether you are 6 or 60, you can always come back to it and find something to do giving relaxation and pleasure.

The Märklin HO model railroad offers special advantages inherent in the design philosophy:

1. Power supply via the central conductor of the Märklin HO track.
2. The exclusive use of alternating current for all parts of the Märklin HO system.

These two together guarantee reliable power supply to the locomotives and electrical circuits, which are easy to follow in even the most complicated layouts. Everything is easy to understand and it is explained in addition in the instructions which accompany the items.

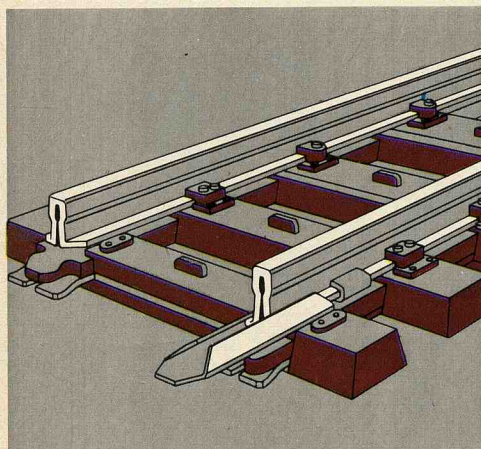

K track (plastic rail ties)
Six-fold connection between track sections, comprising two rail clips, two spring contacts on the central conductor and two couplings on the tie strip.

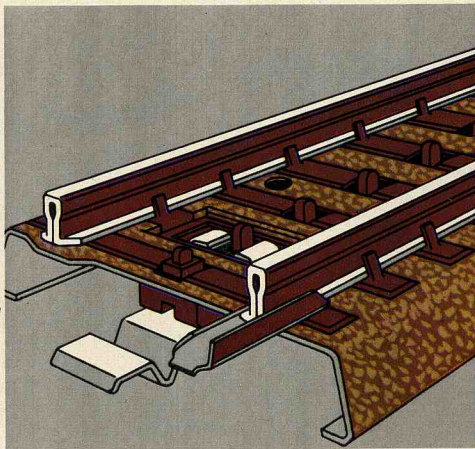

M track (metal track body)
Triple connection between track sections, comprising a sprung clip on the central conductor and two rail clips.

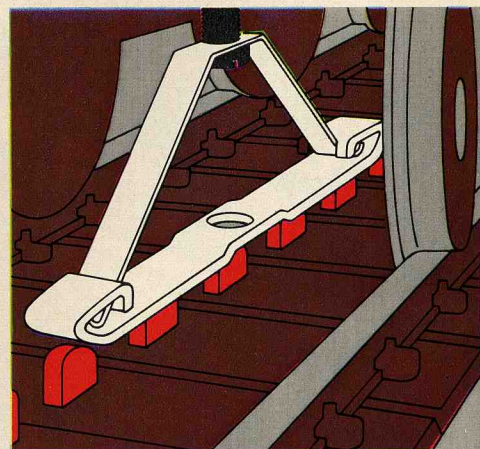

Reliable power supply
to the motor from point contacts via the pick-up shoe. Return of the current via the wheels of the locomotive on both sides.

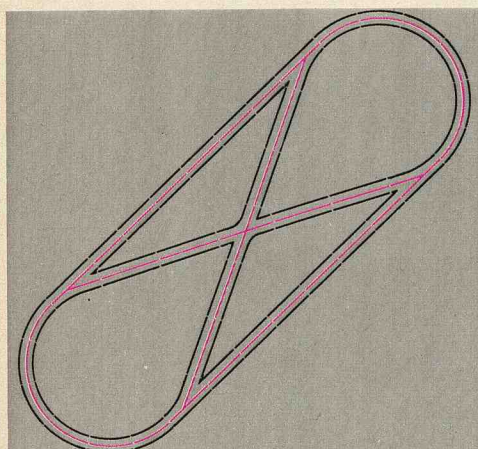

Easy-to-follow current paths without intricate circuitry

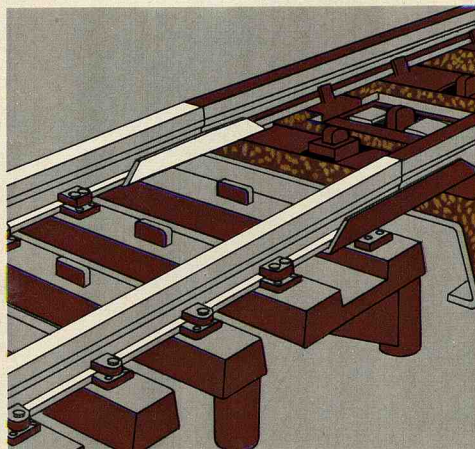

Adapter track sections
used to connect metal tracks to plastic tracks.

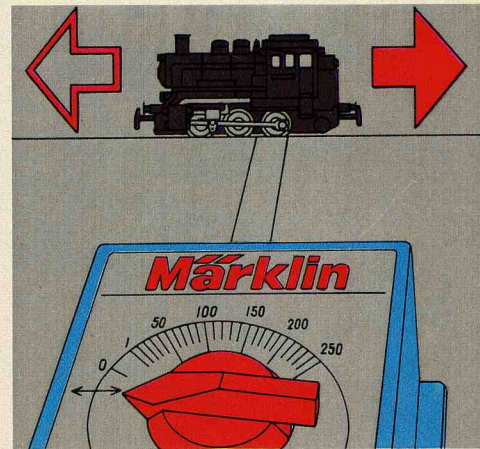

Reversing
of the locomotive by turning the control knob on the transformer anticlockwise (overcurrent pulse).

Precision, reliability and the ease with which the system can be understood are points telling in Märklin's favour.

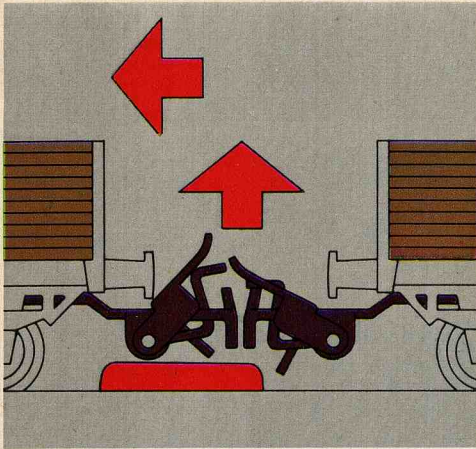

Automatic coupling

When cars are brought into contact, the coupling engages automatically. At the uncoupling track section, uncoupling can be carried out manually or by remote control.

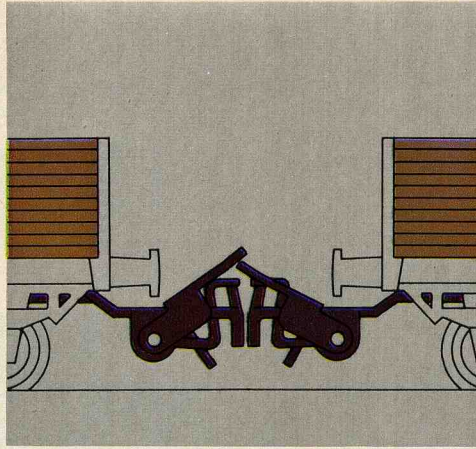

RELEX coupling

After uncoupling, the cars can be pushed for switching without the coupling re-engaging.

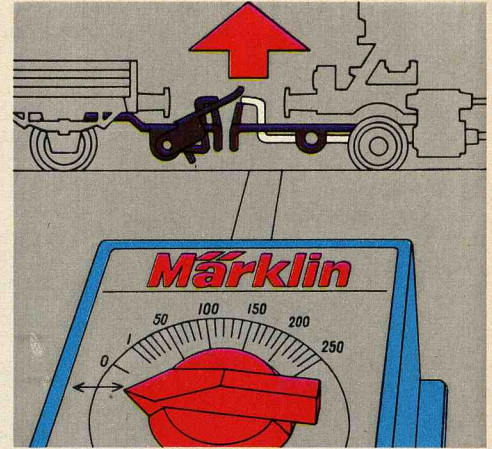

TELEX coupling

At any point in the layout uncoupling can be carried out by remote control from the transformer.

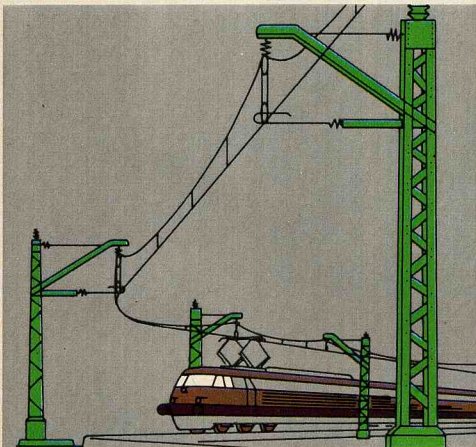

Catenary system

If the overhead conductor is wired up as a second circuit, two locomotives can be run independently of one another on the same track.

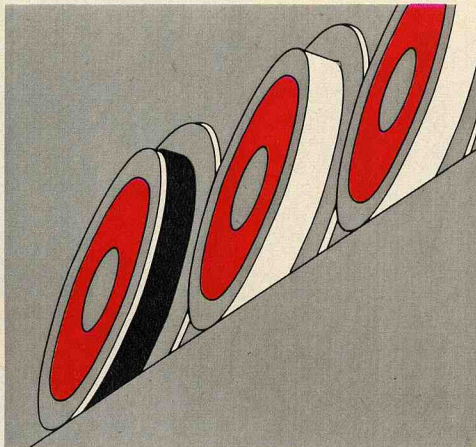

Rubber tires

Used on every locomotive increase the pulling power by improving the grip of the wheels on the rails.

Radio interference suppression

All locomotives are fitted with suppressors. All train sets bear the official German anti-interference symbol. With the use of the feeder track section 5131 or 2192 or the feeder mast 7201 or 7501 and with the exclusive use of Märklin items, which are matched as regards their suppression effect, together with the Märklin transformer recommended, compliance with the legal regulations on interference suppression is ensured.

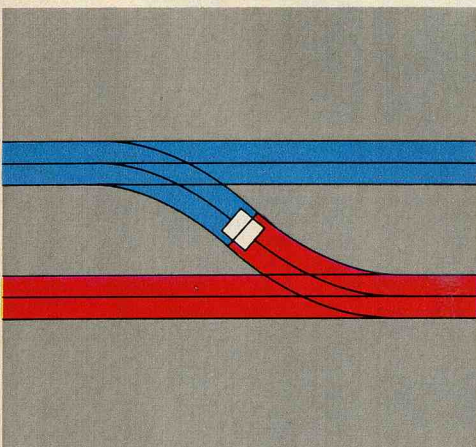

Circuit isolation

By means of the centre conductor insulator 5022 for metal tracks, or the centre conductor insulator 7522 for plastic tracks. Isolating track sections are not required.

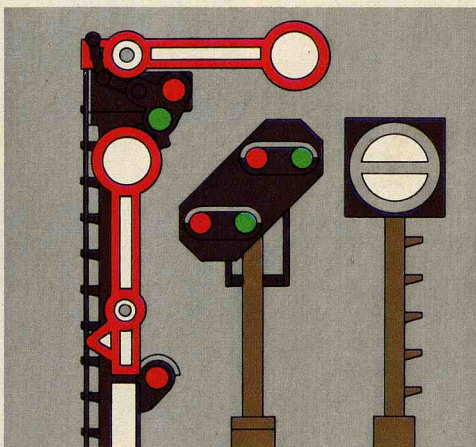

Signals

Enable trains to be controlled entirely automatically.

It is not for nothing that Märklin HO is the model railway with most fans throughout the world.

Prize-winning Märklin models

For the third time running, the readers and editorial staff of the technical journal "Eisenbahn-Magazin" ("Railway Magazine") have honored the firm of Märklin for its successful model developments.

The "Model of the Year 1974" was the heavy Märklin freight train locomotive with cab tender (No. 3084), a model of one of the German Federal Railways' Class 050 locomotives.

Here again are the prize-winning items:

- 1974: for the finest model (Class 050 freight train locomotive with cab tender)
- 1973: for the finest model (Class 003 express locomotive with separate tender)
- 1972: for the development of the smallest series-produced electric railroad in the world: Märklin mini-club.

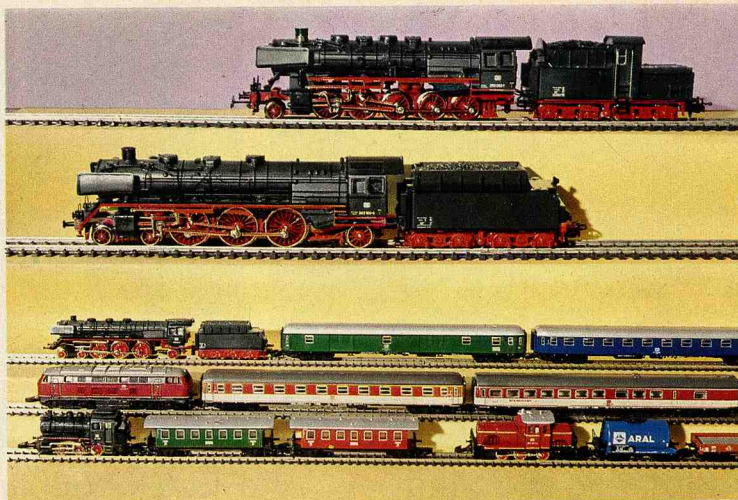

Every Märklin locomotive is of the same quality as the prize winners

In every collection there are models which are pre-eminent.

What matters to the many friends of Märklin however, is that the pre-eminent quality extends across the entire range.

Every Märklin locomotive is, in fact, an original

Before any Märklin locomotive leaves our factory, many experienced hands have worked on it, to test it, assemble it, paint it, decorate it and test it again. This is the only conceivable way of achieving the high standards of originality and reliability, and also the distinctive character which is the mark of every Märklin locomotive.

The 3039 provides the proof thousands of times over

The German Federal Railways' locomotive "110" has been reproduced thousands of times by Märklin as its true-to-original model No. 3039. In model railway operation, the 3039, just like the original, is an electric locomotive with a multitude of applications and must be regarded as part of the standard equipment of any layout.

10 steps up to final inspection

At ten stages during the production process the 3039 is subjected to close inspection.

Every important component unit is checked for serviceability and load-bearing capacity and every 3039 locomotive has proved, by being run on tracks, that it can do everything which you will later expect from it. However, long before the 192 parts are assembled into a perfectly functioning whole, Märklin has set its quality standards. A stringent inspection of all incoming materials and specifications for our own production which go beyond what the Standards require, show how seriously we take our obligation to preserve our tradition.

The name of our tradition is quality.

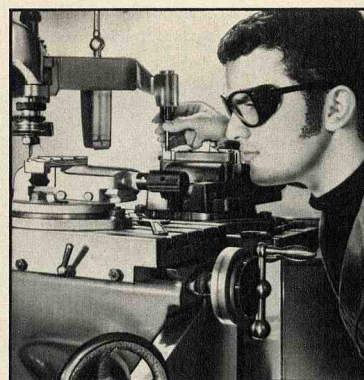

To achieve high precision, mouldings are profile milled.

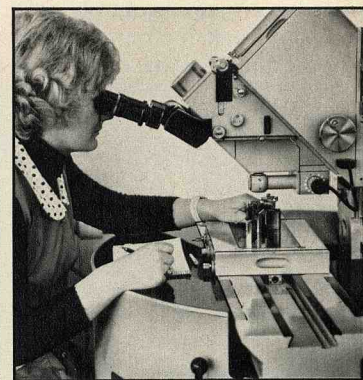

Die and tools are released for use in production only after detailed microscopic measurements.

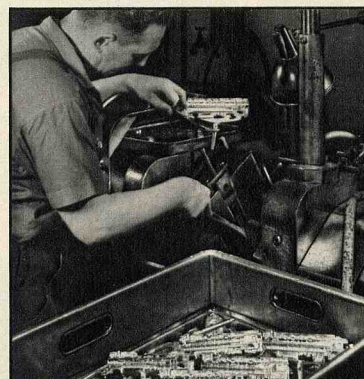

Die-casting of a locomotive frame.



Materials testing under extreme climatic conditions in a temperature and humidity-controlled cabinet.



Adjustment of the reversing switch and testing the operation of the locomotive.



Careful final inspection of the locomotive before release for dispatch.

Märklin locomotives pass every test.

Serial No. Designation

- 1 Locomotive body (complete) with
- 2 Lighting fitting
- 3 Fairing
- 4 Buffer
- 5 Pantograph
- 6 Cheese-head screw
- 7 Cheese-head screw
- 8 Motor bogie (complete) with its most important parts:
- 9 Driving bogie on to which is mounted:
- 9 Extra wheel
- 10 Extra wheel
- 11 Bearing bolt
- 12 Gear-wheel
- 13 Gear-wheel
- 14 Driving axle section with rubber tire
- 15 Driving wheel with
- 16 Rubber tire plus:
- 17 Field magnet
- 18 Armature
- 19 Name plate
- 20 Cheese-head screw
- 21 Pair of brushes
- 22 VHF choke
- 23 Direction reversing switch with
- 24 Reverser unit spring and
- 25 Cheese-head screw
- 26 Frame with change-over switch
- 27 Change-over switch
- 28 Lamp holder
- 29 Light bulb
- 30 Support plate
- 31 Countersunk oval-head screw
- 32 Bogie frame
- 33 Coupling
- 34 Cheese-head screw
- 35 Bogie
- 36 Shoulder screw
- 37 Insulation
- 38 Pick-up shoe
- 39 Countersunk screw

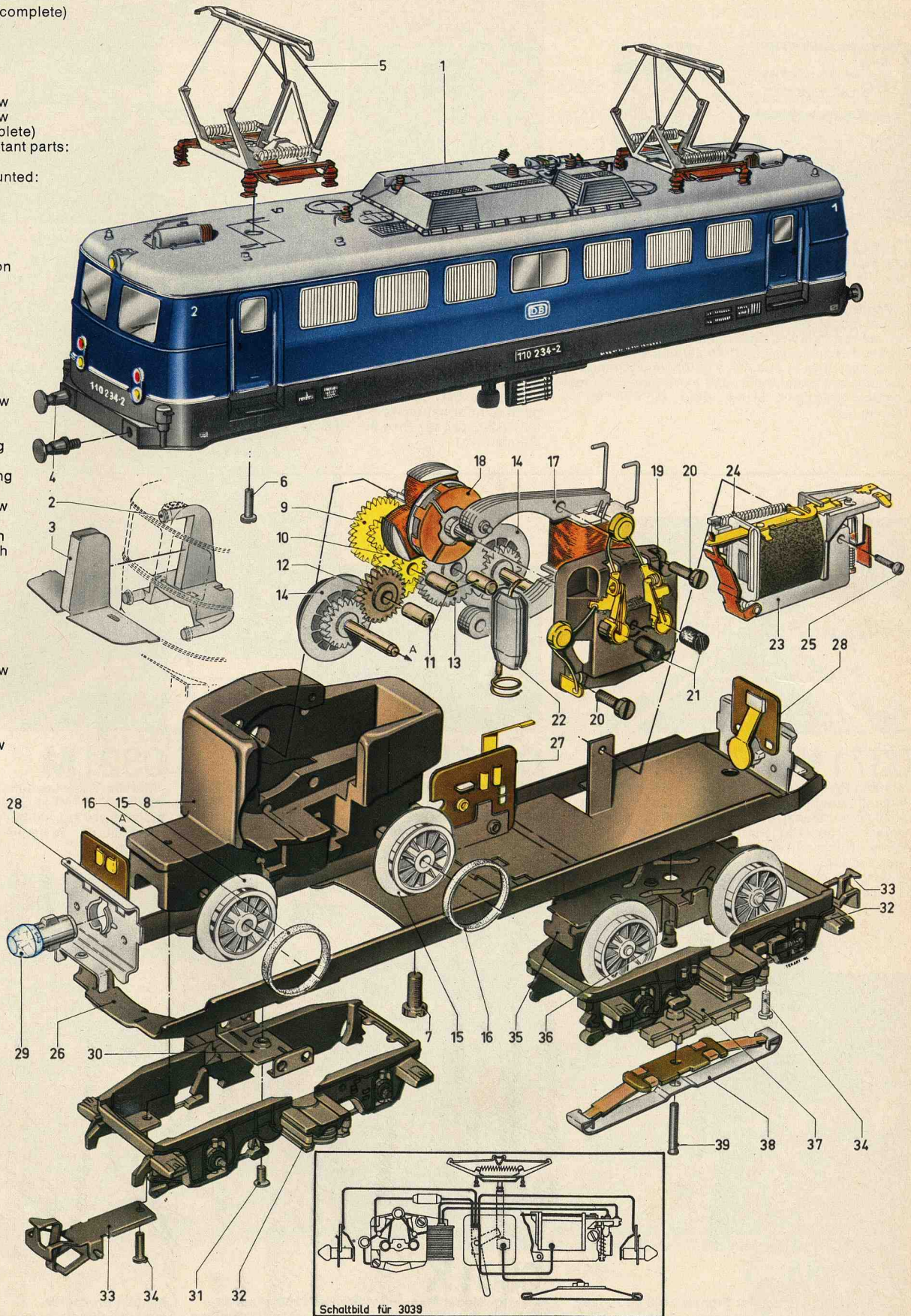

“Top quality”. This was the guiding principle when Theodor Friedrich Wilhelm Märklin founded the firm in 1859 and has been ever since.



0380

“Märklin HO Railroads and their Originals” booklet · A handbook for the Märklin model railroad fan · Among the contents: suggestions for designing landscaped model railroad layouts, the Märklin locomotives and cars and the originals on which they are modelled, signals, railroad regulations and procedures, examples of circuits, e.g. for simultaneous operation of several trains, and much more besides · Contents 228 pages · Size 6” x 9½” (15 x 24 cm) · German text

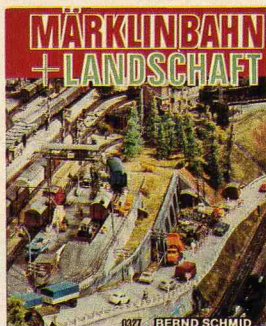

0327

“Märklin Railroad + Landscape” booklet by Bernd Schmid · An outstanding aid in designing your own railroad system · The construction of an HO gauge system is described down to the last detail · The book is copiously illustrated with some of the pictures in colour · Technical details, track layout, landscape planning and the finishing touches to the system are dealt with thoroughly by an acknowledged expert on model railroads · It is a real mine of information for any model railroad enthusiast · 192 pages · Size 6½” x 8” (16.4 x 20.3 cm) · German text

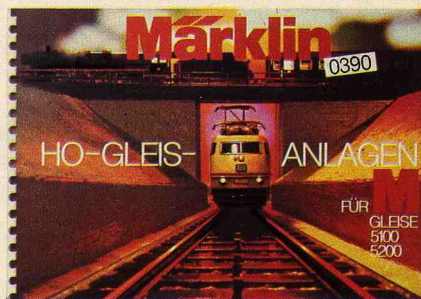

0391 M

“Märklin Track Layouts, HO gauge, for M-tracks 5100 and 5200” · With full color illustrations and detailed track plans for 16 fully developed track examples with catenary systems · The individual electrical circuits are marked in distinguishing colors · The accompanying text contains many track and turnout suggestions · An outstanding aid to the construction of even the largest layouts · 56 pages · Size 8¼” x 11¾” (21 x 30 cm) · English text



0371 K

“Märklin HO gauge Track Layouts for K-tracks 2100” · With fullcolor illustrations and detailed track plans for 16 comprehensive layouts, including catenary systems · The various circuits are shown in different colors · This publication also contains many plans of track and turnout combinations · An outstanding guide to the building of layouts, even large ones · 52 pages · Size 8¼” x 11¾” (21 x 30 cm) · English text

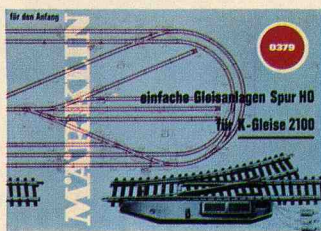

0379 K

“Märklin HO gauge Track Layouts for K-tracks 2100” contains 7 simple track plans · 20 pages · Size 6” x 8¼” (15 x 21 cm) · English text



0321 M

“Märklin Track Layouts, HO gauge, for M-tracks 5100 and 5200” · With 11 simple track plans · These systems are easy to build and offer many playtime possibilities · 24 pages · Size 6” x 8¼” (15 x 21 cm) · English text

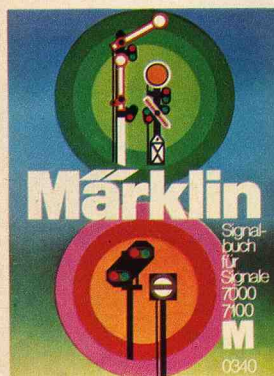

0341 M

Märklin Signal Manual for Signals 7000 and 7100 · This explains in detail, with color illustrations, how signals and universal remote control switches of the 7000 and 7100 series are incorporated into an M-track system and used · 28 pages · Size 7” x 9¾” (18 x 25 cm) · English text



0361 K

Märklin Signal Manual for Signals 7200 · This explains in detail, with the aid of six-color illustrations, how signals and universal remote control switches of the 7200 series are incorporated into a system and used · 48 pages · Size 7” x 9¾” (18 x 25 cm) · English text

Märklin brochures are available from your Märklin dealer

Everything about the HO gauge Märklin model railroad clearly explained and abundantly illustrated.

Märklin
magazin

2/75

für große und kleine Modell-Eisenbahner DM 2,80



The magazine for all model railroaders, young and old, reports on interesting topics connected with model railroads.

The Märklin Magazine contains reports on real railroad practice and model railroad operation in interesting and stimulating articles. A lively well-illustrated Magazine, it provides much worthwhile information for all model railroad enthusiasts, it gives useful hints and tips, it makes what seems complicated understandable, in short, with it, every model railroader can become a perfect model railroader. The Märklin Magazine is published quarterly in German. An annual subscription makes a welcome present.

Available from:
**Modellbahnen-Welt
Verlags-GmbH,
732 Göppingen, Postfach 940**

or from your Märklin dealer,
or through bookshops.

Our suggestion for
an ideal start:

SET-HO 123
with Toporama 7298

This layout consists of basic set **S** (2920—2929 or 2930—2939), extension set **E** 5190 or 5191, double track set **T** 1 5192, station track set **T** 2 5193 and switching track set **T** 3 5194 = SET 123. See page 26 for track plan and part list in this connection and note what is said on pages 24—27.

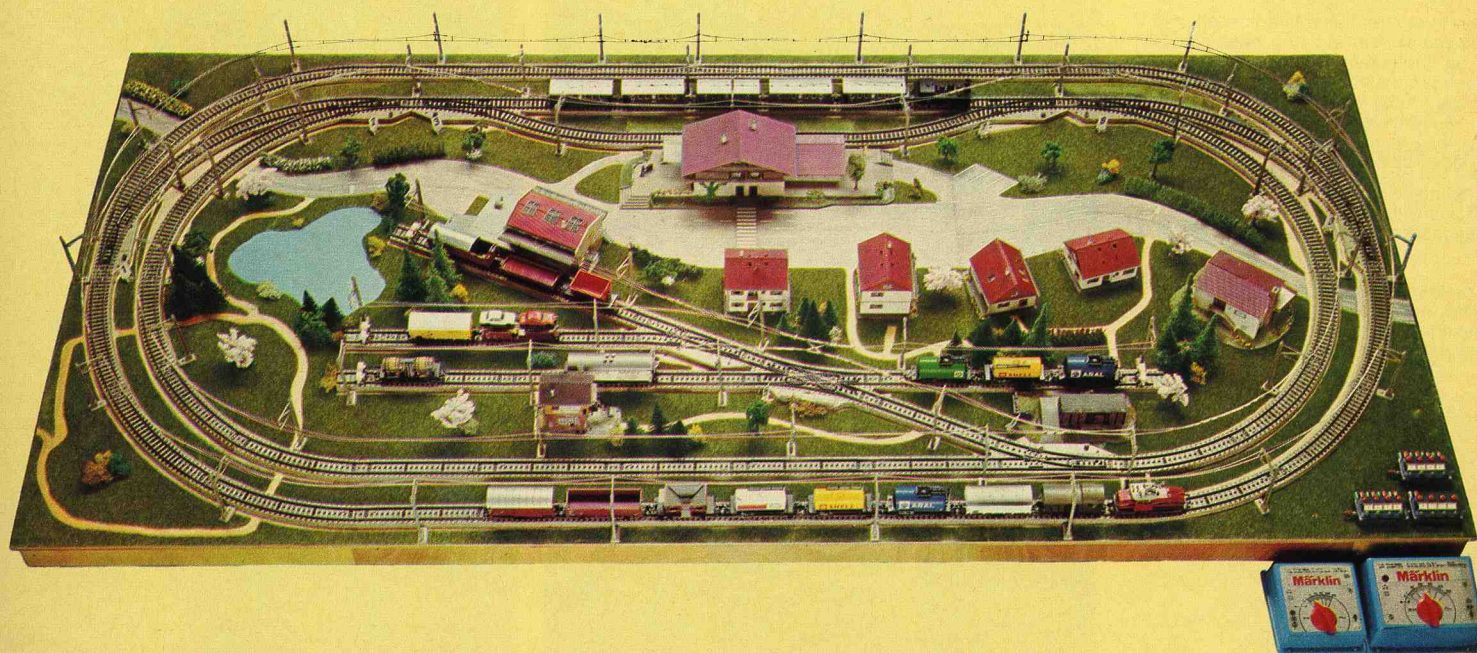

**Model railroad fans turn into experts.
Even for experts there is always something new.**

An ideal suggestion right at the start

Märklin HO

Construction programme leading to the ideal HO layout

SET-HO

The start consists of a **gift set S** containing **Passenger train S 2920—2929** or **Freight train S 2930—2939** each with transformer and oval track (see page 27).

The first extension stage consists of **Extension set E 5190** or **Extension set E 5191**.

From here on, three further track extension sets are available for building the ideal HO layout:

- Double track set T 1 5192**
- Station track set T 2 5193**
- Switching track set T 3 5194**

These three track sets T 1, T 2 and T 3 can be added in any order. Here we show only four of the ways which lead from a small beginning to the ideal HO layout. Any one of these four ways are possible depending on the way you prefer to operate your layout, or you can devise some other variation of your own. That is how simple it is to construct the ideal HO layout using the Märklin SET-HO construction programme.

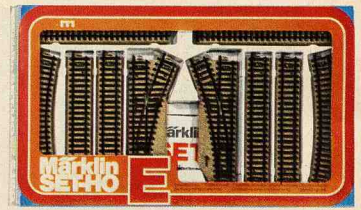

5190

Extension set E - Contents: 10 straight track sections 5106, 2 curved track sections 5206, 1 pair of manually operated turnouts 5221 and instructions for extending the layout



Passenger train S 2920—2929



Freight train S 2930—2939

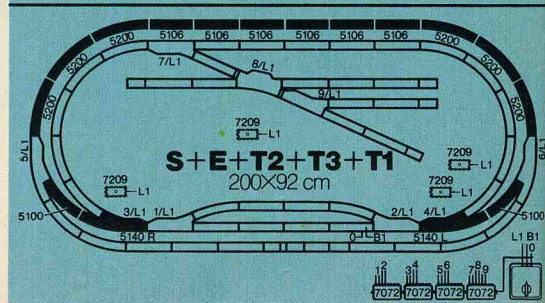
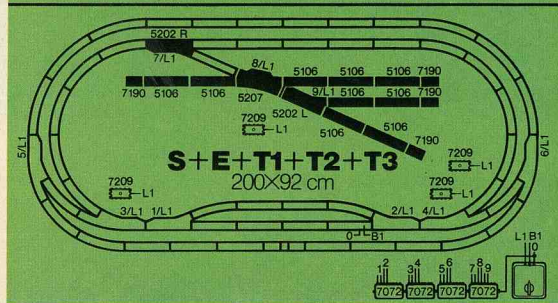
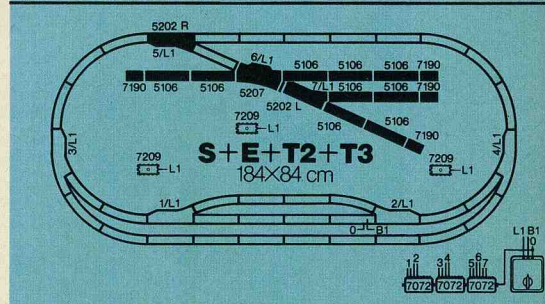
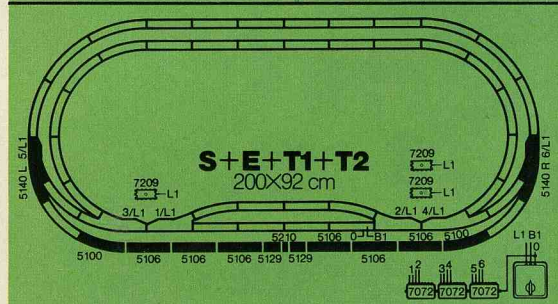
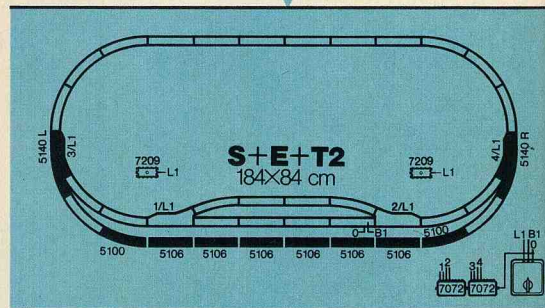
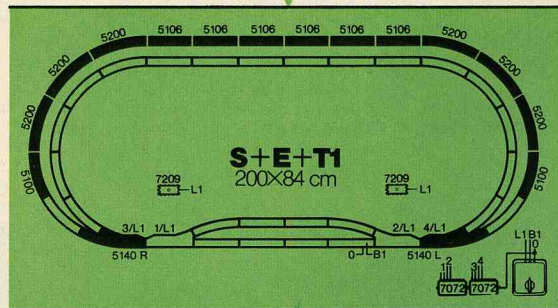
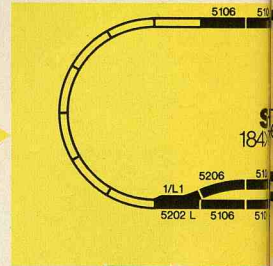
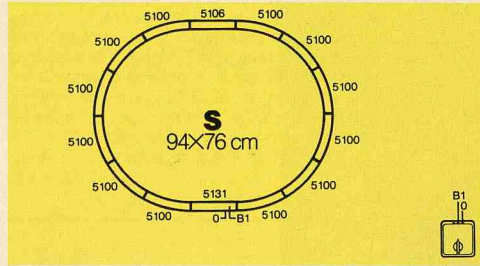

The HO catenary system provides the Märklin SET-HO construction programme with its culmination. On page 26 you will find a very interesting suggestion in this connection.

The Märklin range offers in addition many accessories which enrich the means of enjoyment, e.g. the Märklin slewing crane 7051 (see page 71).

Why not start small?
Märklin SET-HO will grow with you.



5191

Extension set E · Contents: 10 straight track sections 5106, 1 pair of solenoid-operated turnouts 5202, 2 curved track sections 5206, 1 turnout control panel 7072, 1 distributor plate 7209, with material for making the connections, such as leads, sleeves and plugs · Instructions for extending the layout

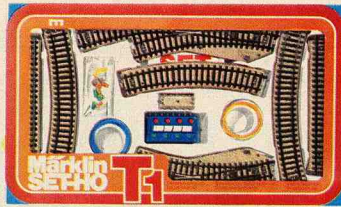

5192

Double track set T 1 · Contents: 2 curved track sections 5100, 6 straight track sections 5106, 1 pair of solenoid-operated curved turnouts 5140, 6 curved track sections 5200, 1 turnout control panel 7072, 1 distributor plate 7209, with material for making the connections, such as leads, sleeves and plugs · Instructions for extending the layout

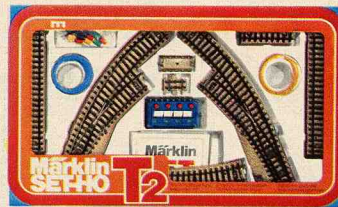

5193

Station track set T 2 · Contents: 2 curved track sections 5100, 6 straight track sections 5106, 2 straight track sections 5129, 1 pair of solenoid-operated curved turnouts 5140, 1 straight track section 5210, 1 turnout control panel 7072, 1 distributor plate 7209, with material for making the connections, such as leads, sleeves and plugs · Instructions for extending the layout

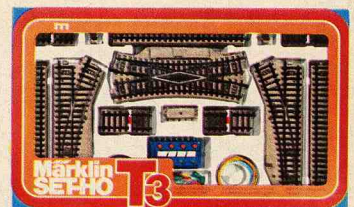

5194

Switching track set T 3 · Contents: 9 straight track sections 5106, 1 pair of solenoid-operated turnouts 5202, 1 double slip 5207, 1 turnout control panel 7072, 4 buffer stops 7190, 1 distributor plate 7209, with material for making the connections, such as leads, sleeves and plugs · Instructions for extending the layout

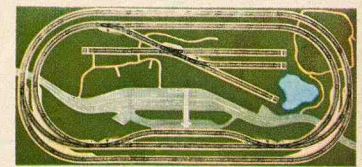
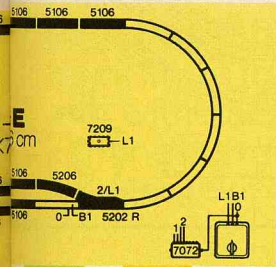

7298

Märklin Toporama for the Märklin SET-HO construction programme leading to the ideal HO layout · Printed, true-to-nature model railroad landscape · Multicolor printing giving the layout of the track up to SET 123 · Tufted grass areas produce an effect of relief · Size 80 1/2" x 38" (205 x 97 cm)

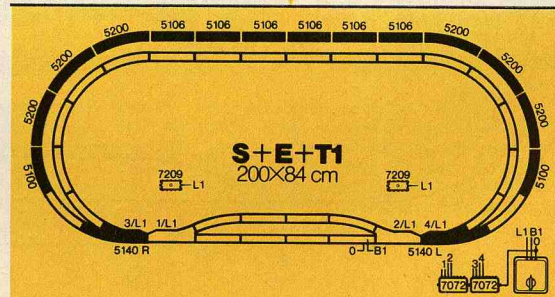
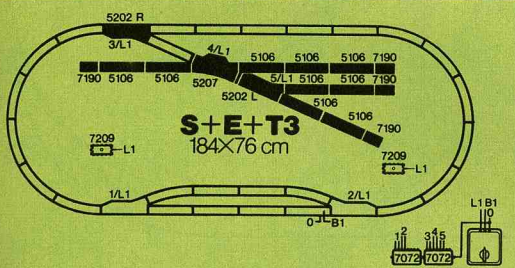

The Märklin Toporama landscape 7298 is highly recommended as an elaboration for Märklin SET-HO. It can be used starting at stage E (5190, 5191). The track layout up to stage T 3 (5194) is preprinted on it.

And how is the Toporama used?

It is quite simple. Place the Toporama mat on a base, glued or fastened as you wish, lay out the track as it is printed out to full scale, make the connections and you are ready to start your long trip. No other landscaping is necessary; the Märklin Toporama already has meadows, streams, lakes, roads and parking places.

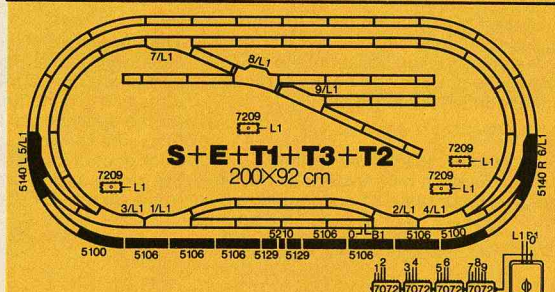
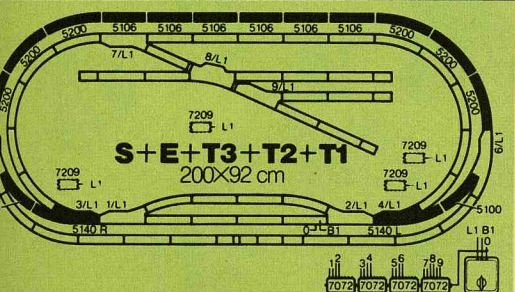
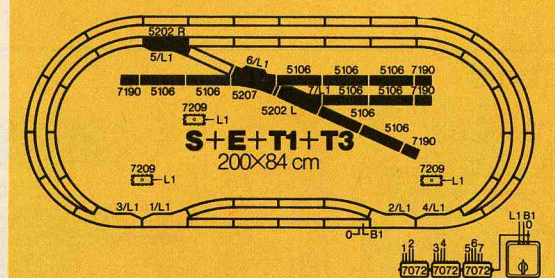
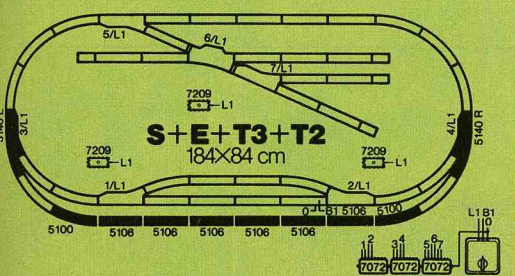

From a ready-to-operate gift set, clear steps lead on to the ideal HO layout.

SET-HO 123 M-track plan with Toporama 7298 80 1/2" x 38" (205 x 97 cm)

See page 23 for a photograph of the track plan

Parts list

The following items were used to construct this ideal HO-gauge model railroad layout:

- | | |
|--------------------------------|--------|
| 1 transformer out of 2920/2930 | |
| 16—5100 | 4—7209 |
| 32—5106 | 1—7101 |
| 2—5129 | 1—7103 |
| 1—5131 | 4—7111 |
| 2—5140 | 4—7112 |
| 6—5200 | 9—7113 |
| 2—5202 | 9—7115 |
| 2—5206 | 4—7131 |
| 1—5207 | 4—7132 |
| 1—5210 | 9—7133 |
| 4—7072 | 9—7135 |
| 4—7190 | |

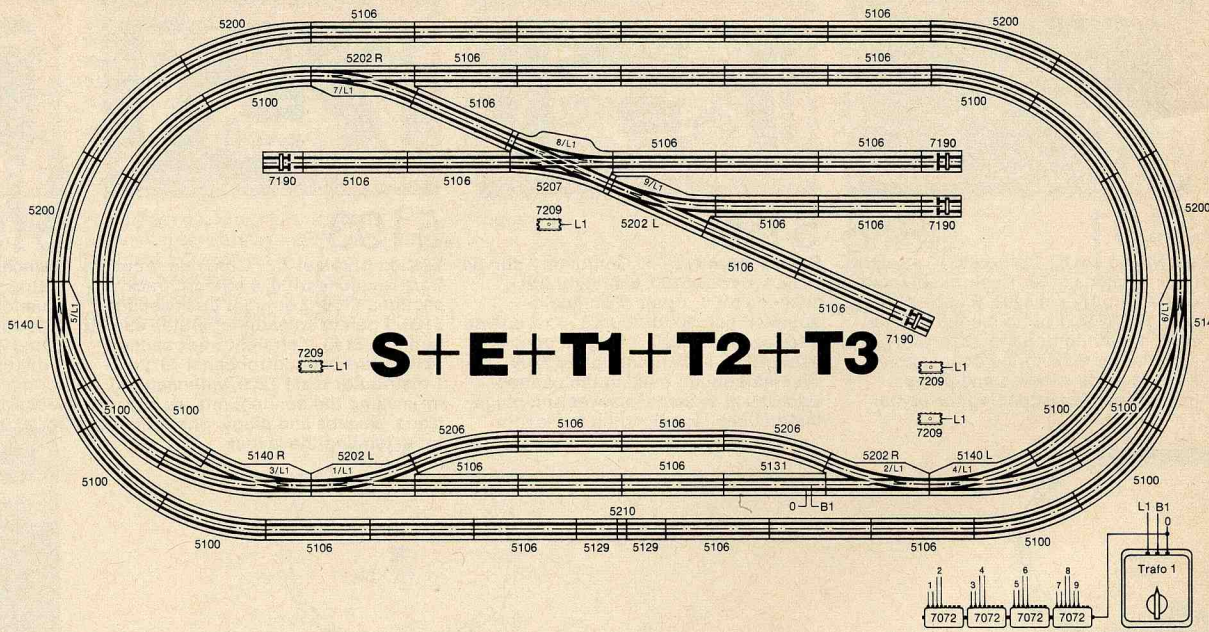

Catenary system

1 transformer 30 VA

- | | |
|---------|--------|
| 3—7004 | 7—7019 |
| 54—7009 | 9—7023 |
| 10—7013 | 1—7201 |
| 16—7014 | 1—7277 |
| 16—7015 | 2—7278 |
| 22—7018 | |

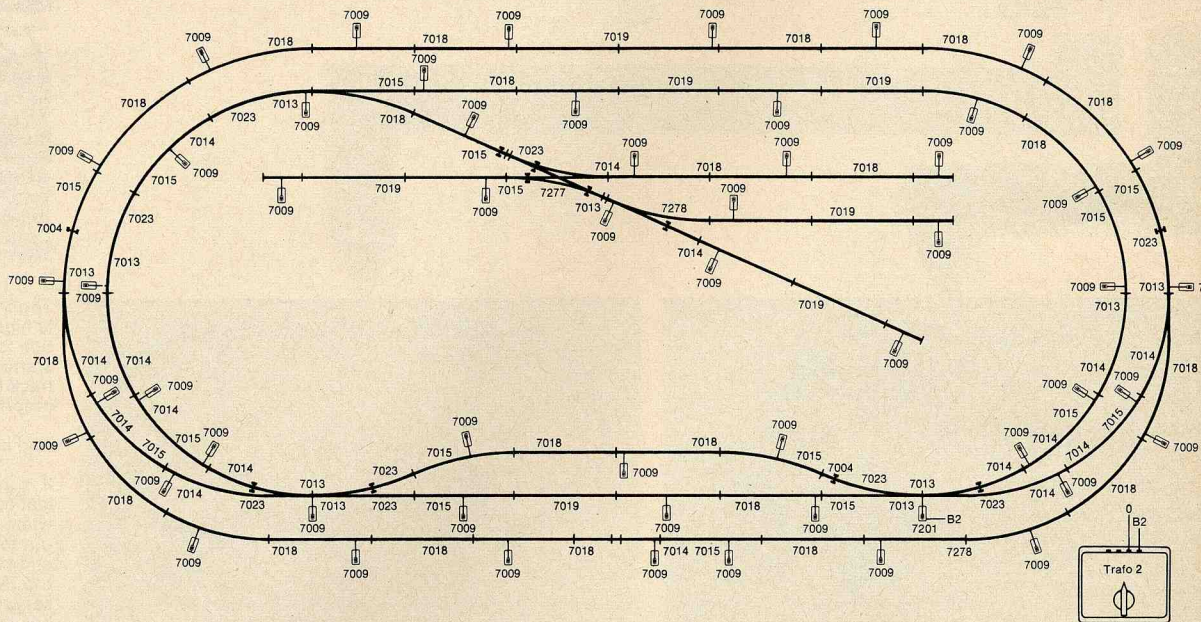

Explanations of the symbols on the track plan

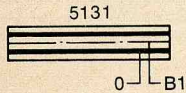

0 B1
Traction current feeder section for the point contact conductor. Red and brown leads to sockets of the same color on transformer 1.

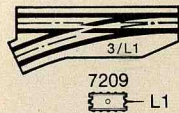

3
Blue lead with green plug in green socket; blue lead with red plug in red socket, e.g. the red socket of the pair of sockets marked "3" on the turnout/signal control panel (7072).

L1
Yellow lead to the yellow lighting current socket L on transformer 1 or on the distributor plate L1 connected to it.



B2
Traction current feeder mast for the catenary system. Red lead to red socket on transformer 2. If there is not already a ground lead—brown lead—for the operation of the track point contacts, the brown leads from the feeder track sections must be connected to the brown socket on the transformer or to the distributor plate connected to it.

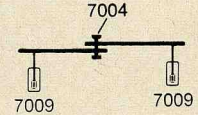

The overhead contact lines are connected by means of fixing kit 7004 (bolt, nut and washer).

This is the final layout –
built-up step by step, with no problems.

Basic sets in gift packs

and their ideal use see pages 23—26.

Märklin HO



2920 S 220 volt

2924 S 240 volt England

2926 S 110 volt

2927 S 110 volt USA

2929 S 100 volt Japan

All train sets on this page have an oval track and a transformer with traction and lighting current connections.

Passenger train with transformer · With double end locomotive, 2 passenger coaches, 12 curved track sections 5100, 1 straight track section 5106, 1 feeder track section 5131 with built-in capacitor for radio interference suppression and 1 transformer · Length of train 13¾" (35 cm)

The transformers included with these train sets, like all Märklin transformers, have connections for traction current and current for lights and solenoid-operated items and furthermore they provide an overvoltage for reversing the locomotives. The transformer is also capable of being used to operate bigger locomotives or additional turnouts or signals. The transformer switches itself off if overloaded or if the temperature rises excessively.



The transformers supplied with these basic sets are not available separately.



2930 S 220 volt

2934 S 240 volt England

2936 S 110 volt

2937 S 110 volt USA

2939 S 100 volt Japan

Fully extendable basic sets.

Freight train with transformer · With locomotive 3000, 2 freight cars, 12 curved track sections 5100, 1 straight track section 5106, 1 feeder track section 5131 with built-in capacitor for radio interference suppression and 1 transformer · Length of train 12½" (31.5 cm)

For the basic sets 2920—2929 and 2930—2939 we recommend Märklin SET-HO, the construction programme leading to the ideal HO layout, using items E (5190, 5191), T 1 (5192), T 2 (5193) and T 3 (5194). See pages 23—26 for detailed description.



Connect transformers to AC mains supply only.



The first train drives off – the foundation stone for the ideal layout has been laid.

Train sets
without transformer
with oval track —
full extension
capability

3203

Freight train (without transformer) · Consisting of locomotive 3003, 3 freight cars, 12 curved track sections 5100, 1 straight track section 5106 and 1 feeder track section 5131 with built-in suppressor · Length of train 21" (53 cm)

For enlarging the train sets 3203, we recommend Märklin SET-HO for building up to the ideal HO layout, using items E (5190, 5191), T 1 (5192), T 2 (5193) and T 3 (5194). Detailed descriptions are given on pages 23—26.

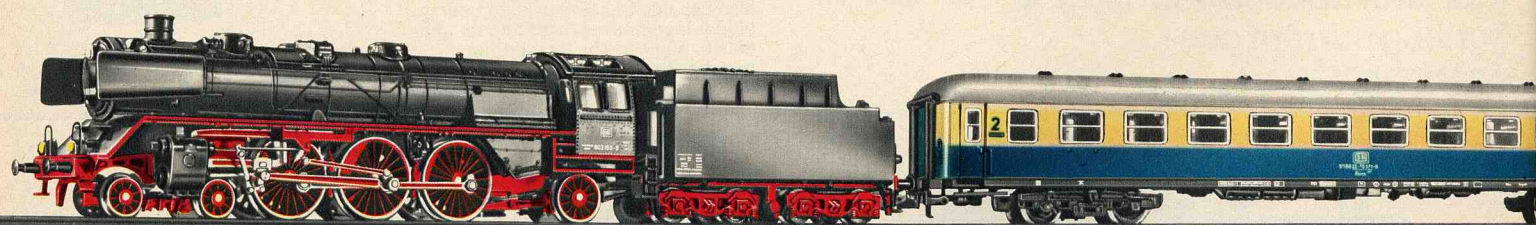

3185

Express train with turnouts (without transformer) · Consisting of express locomotive 3085, 1 each passenger cars

4092, 4093 and 4094, 12 curved track sections 5100, 18 straight track sections 5106, 1 straight track section 5108, 1 feeder track section 5131 with built-in suppressor, 1 pair solenoid-operated

turnouts 5117, 1 control panel 7072 and 4 leads · Length of train 44" (113 cm)

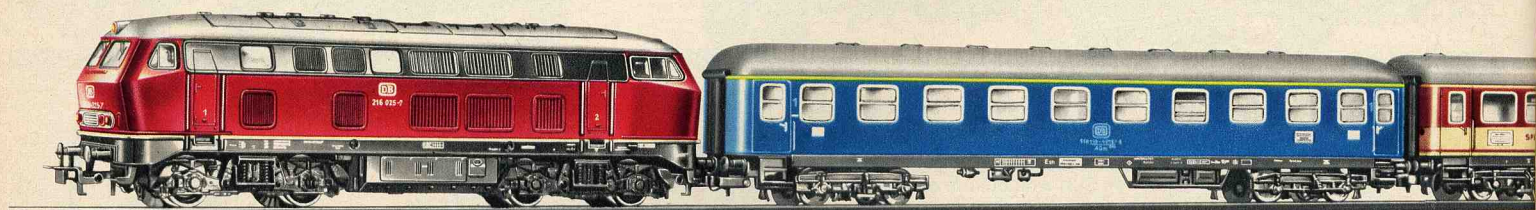

3175 **new**

Express train (without transformer) · Consisting of Diesel locomotive 3075, 2 express passenger cars with interior

fittings, 1 express baggage car, 12 curved track sections 5100, 5 straight track sections 5106 and 1 feeder track section 5131 with built-in suppressor · Length of train 36 3/4" (93.5 cm)

For enlarging train sets 3175 and 3185 we recommend the publications "Track layouts, HO-gauge, for M-tracks" 0321 and 0391 (see page 22).



A delightful start of a fascinating hobby

Gift boxes – A good idea

These bigger train sets not only have more cars and more tracks, they also have the advantage of being just as suitable for giving away as presents as for buying for oneself. What a good way to start on a bigger scale for example. The only extra purchase needed is one of the transformers on page 77 and the set is immediately ready to run.

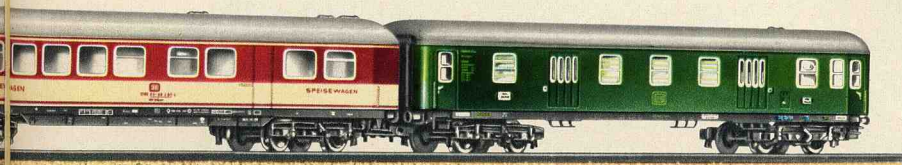
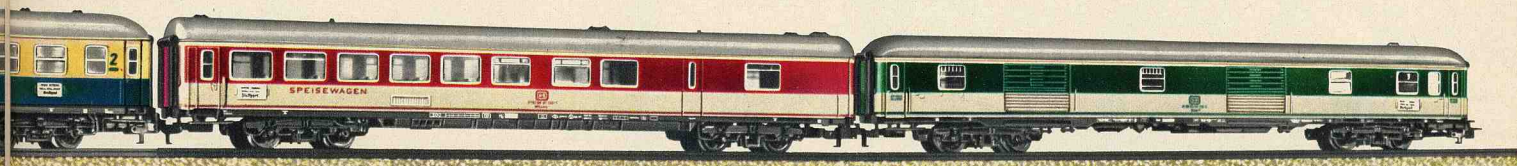
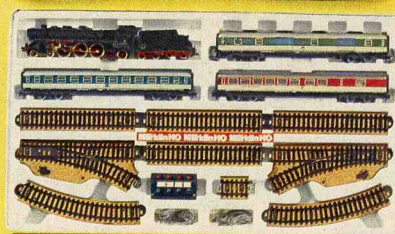

Train sets
without transformer
with oval track –
full extension
capacity

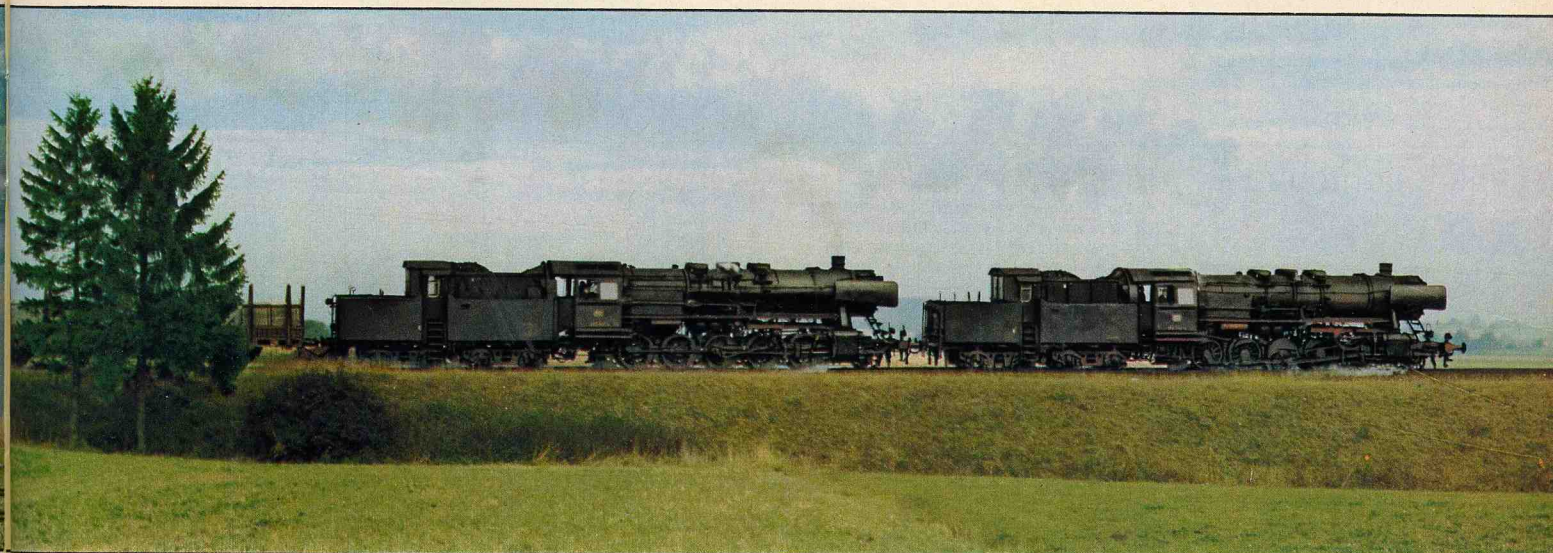

The finest present for any model railroad fan

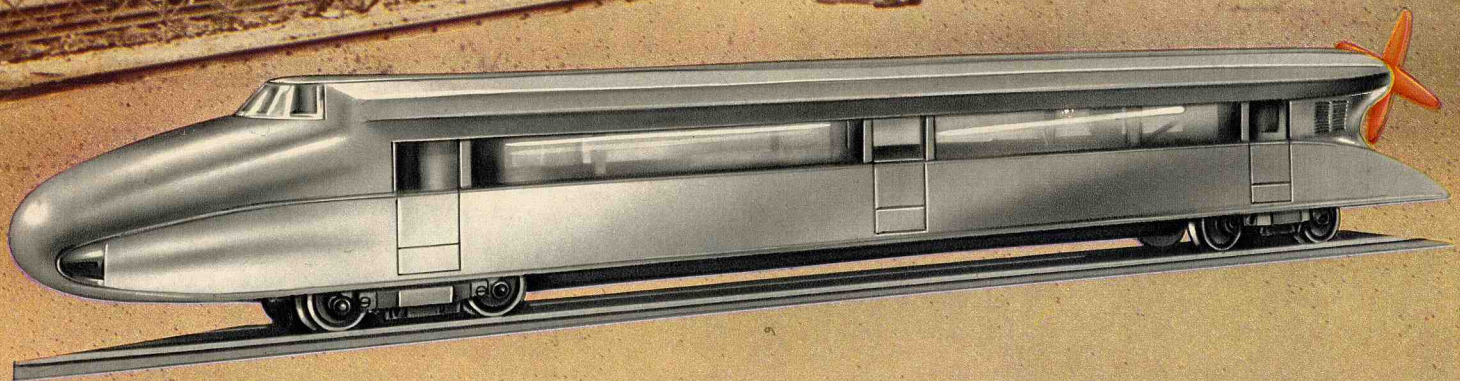
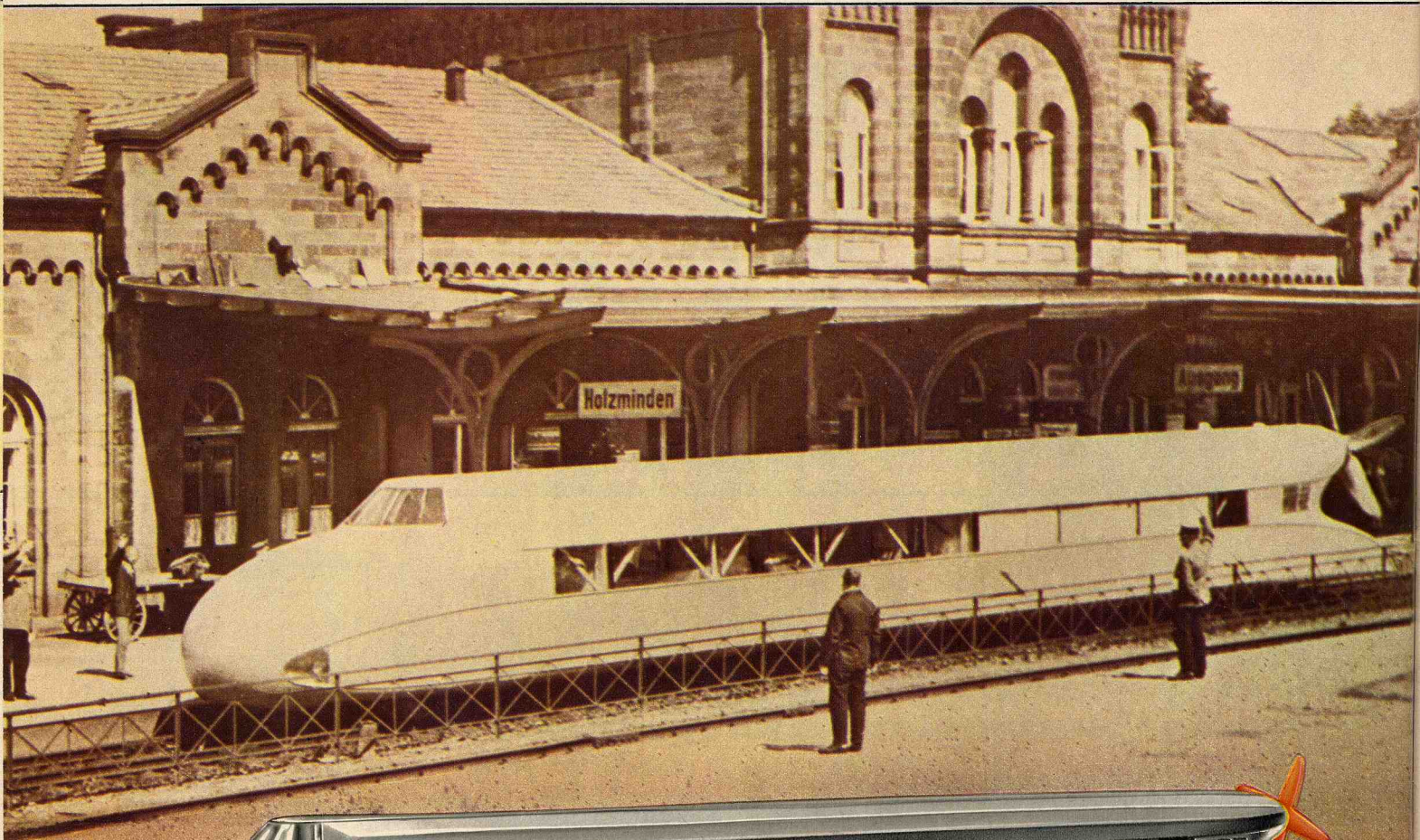

Rail Zeppelin 3077 **new**

Rail Zeppelin based on Kruckenberg's system · 4 axles · 2 driven axles · 4 rubber tires · Remote control for forward and reverse drive · When the traction voltage is slowly increased, the special motor first starts the propeller and then the locomotive · 2 working headlights · Silver grey plastic

body · Fitted windows with simulated struts · Die cast zinc frame · Length 11 1/3" (28.8 cm)

⊙ = 7154 🚂 = 7164 💡 = 60015

The Rail Zeppelin built from the designs by Franz Kruckenberg for the Flugbahn-GmbH reached speeds up to 143 mph (230 km/h) during reliability test runs carried out in 1931. That was a world record. The drive was obtained from a stern-mounted BMW aircraft engine of 600 HP which drove a propeller.

new
8377



The same as model 3077 but for two-rail D.C. operation (see page 35)

Tank locomotive 3000

Tank locomotive · Model of the 0-6-0 Class 89 locomotive · 3 driven axles · 2 rubber tires · Remote control for forward and reverse drive · Three working headlights · Mat black plastic body · Die cast zinc frame · Coupling hook at each end · Length over buffers 4 1/3" (11 cm)

⊙ = 7154 🚂 = 7185 💡 = 60010

Because of the many uses to which they can be put for passenger and freight train service and especially for work in switching yards, their design and the ease with which they can be put on the track, many people favor these tank locomotives. Their ability to stay on curves at high speed and to pull heavy loads and their attractive appearance are special advantages of these locomotives.

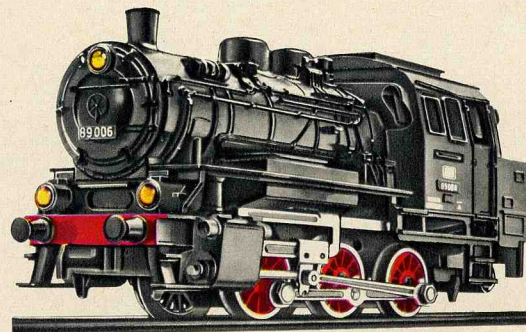

The high-speed rail motor unit – as stylish as it is unique

Tank locomotive

3087

Tank locomotive modelled on a 0-6-0 type locomotive used on secondary lines · 1 driven axle · 2 rubber tires · Remote control for forward and reverse drive · Green/black plastic body · Water tanks and driver's cab green · Die cast zinc frame · Coupling hooks at each end · Length over buffers 4 1/4" (10.8 cm)

⊙ = 7154 🚂 = 7185



Tank locomotive

3090

Tank locomotive modelled on a 0-6-0 type locomotive used on secondary lines · 1 driven axle · 2 rubber tires · Remote control for forward and reverse drive · Mat black plastic body · Die cast zinc frame · Coupling hook at each end · Length over buffers 4 1/4" (10.8 cm)

⊙ = 7154 🚂 = 7185

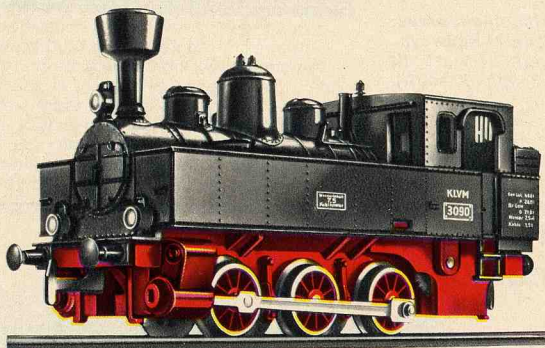

"BR 74" A very desirable Märklin model

3095

Tank locomotive · A model of the German Federal Railways' 2-6-0 Class 74 engine · 3 driven axles · 2 rubber tires · Simulated Heusinger reversing gear · Remote control for forward and reverse drive · Three working headlights · Mat plastic black body · Die cast zinc frame · Coupling hook with advance uncoupler at the front, automatic coupling with advance uncoupler (RELEX) at rear · Length over buffers 5 1/4" (13.5 cm)

⊙ = 7153 🚂 = 7185 ⚙ = 60010

The first of these superheated steam tank locomotives was put into service by the Berlin State Railways Directorate in 1902. They proved so successful that hundreds of engines of this type worked untiringly for suburban passenger services up to the time when the Berlin Circle and Metropolitan lines were electrified in the nineteen-twenties. Over the years nearly 1000 of these very reliable engines were built. When they were no longer required in Berlin, they were allotted to numerous centres for use on short distance passenger services and switching operations. Their length was 38 ft. 8" (11.80 m) to 39 ft. 8" (12 m). Weighing 70 tons in working order, they could reach a speed of 50 mph (80 km/h) either forwards or backwards.

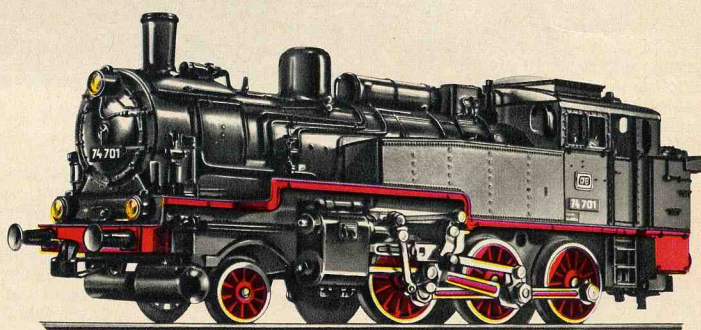

"BR 86" Standard locomotive used on the German Federal Railways with Märklin TELEX coupling

3096

Tank locomotive · A model of the Class 86 2-8-2 locomotive of the German Federal Railways · 4 driven axles · 2 rubber tires · Simulated Heusinger reversing gear · Remote control for forward and reverse drive · Three working headlights at each end · Outstandingly detailed black plastic body with many extras mounted · Die cast zinc frame · **Märklin TELEX coupling** at each end · Length over buffers 6 1/4" (15.8 cm)

⊙ = 7153 🚂 = 7164 ⚙ = 60015

The standard Class 86 locomotive developed for mixed service on heavily-used secondary lines, was well represented by the respectable total of 774 engines in the stocks of the former German State Railways. The German Federal Railways took over 385 of them. Some of them were equipped with Krauss-Helmholtz frames which increased their speed from about 45 mph (70 km/h) to 50 mph (80 km/h). The length of these locomotives is 46 ft. 6" (13.82 m). With a weight of 88.5 tons in working order, the maximum axle load is 15.6 tons.

8396

The same model as 3096 but for two-rail D.C. operation (see page 35) and without TELEX coupling

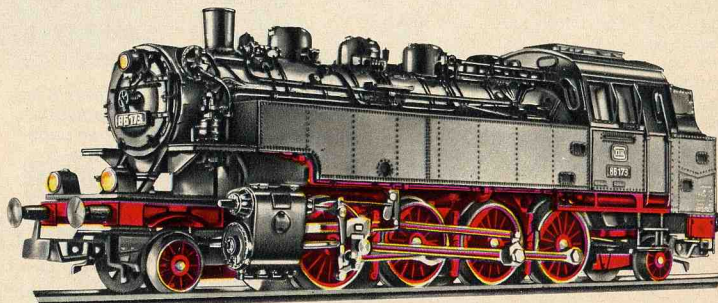



The Märklin **TELEX coupling** enables the attached train to be uncoupled at any desired point on the system, by remote control from the transformer. Coupling up can be done by using the automatic coupling again at any desired point. No additional accessories are necessary. The following locomotives are equipped with Märklin TELEX couplings: 3096 and 3065 (see page 41).

Uncouple by remote control at any point in the layout using the Märklin TELEX coupling

Mixed traffic steam locomotive

3003

Passenger locomotive with tender · A model of the German Federal Railways' 2-6-0 Class 24 engine · 3 driven axles · 2 rubber tires · Simulated Heusinger reversing gear · Remote control for forward and reverse drive · Three working headlights · Mat black plastic body · Die cast zinc frame · Coupling hook in front and automatic uncoupler (RELEX) on tender · Length over buffers 7 7/8" (20 cm)

0 = 7153  = 7185  = 60010

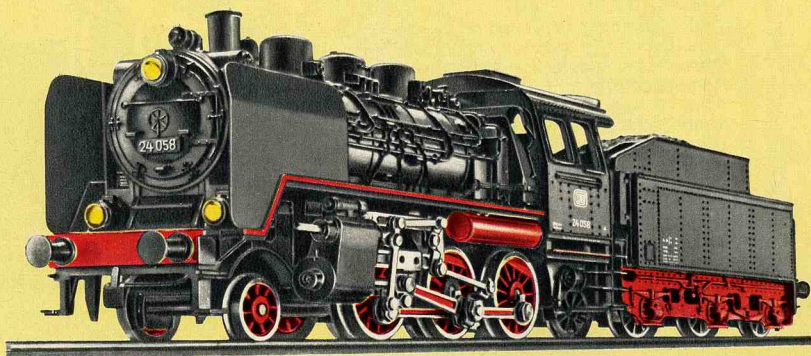

The standard Class 24 locomotive was used on the German Federal Railways for passengers and freight services. Its maximum speed was 56 mph (90 km/h).



Belgian State Railways locomotive with tender

3086

Locomotive with tender · A model of the Belgian State Railways' (NMBS/SNCB) Class 64 4-6-0 locomotive · 3 driven axles · 2 rubber tires · Simulated Heusinger reversing gear · Remote control for forward and reverse drive · Three working headlights · Green metal body with bronze-colored boiler rings and external piping · Die cast zinc frame · Coupling hook at front, automatic uncoupler with advance uncoupler (RELEX) on tender · Length over buffers 8 1/2" (21.4 cm)

0 = 7152  = 7185  = 60015

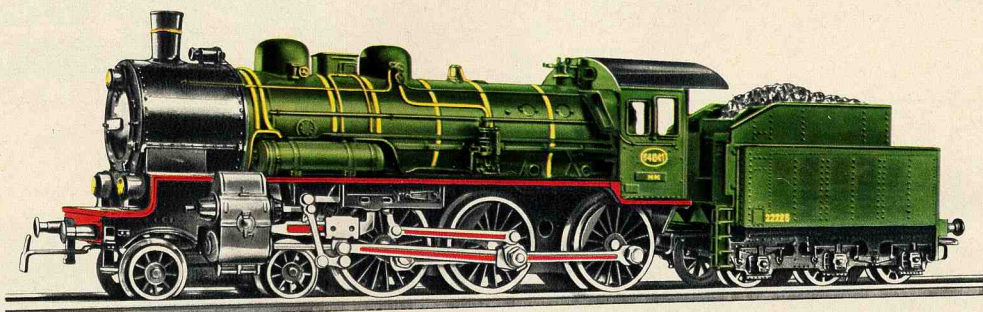



"BR 18" Express locomotive

3093

Express locomotive with tender · A model of the 4-6-2 Class 18^a German Federal Railways' locomotive (Bavarian S 3/6 series i) · 3 driven axles · 2 rubber tires · Simulated Heusinger reversing gear · Remote control for forward and reverse drive · Three working headlights · Mat black metal body · Very fine detailing of valves · Die cast zinc frame · Automatic uncoupler with advance uncoupler on tender (RELEX) · Length over buffers 9 3/4" (24.9 cm)

Arranged to take the smoke unit accessory 7227 (see page 74)

0 = 7152  = 7185  = 60015

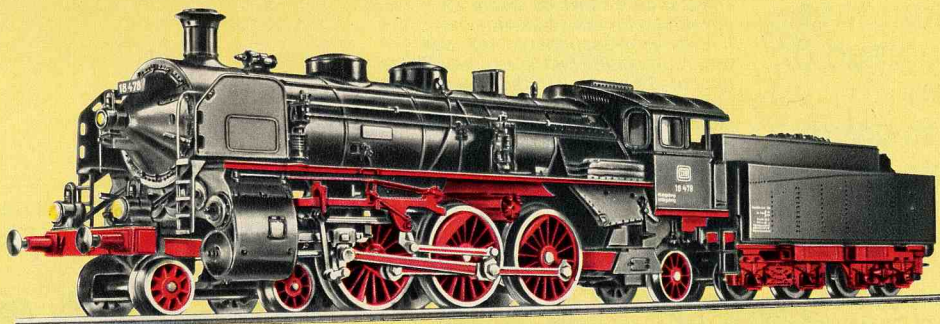

Connoisseurs regard the Bavarian S 3/6 Class locomotives with their powerful cylinder group, clearly arranged underframe, fairings and characteristic flared smoke stack, as the finest of all steam locomotives. The S 3/6s, whose designation was later changed to Class 18^a by the German State Railways, were often used to pull international expresses, including the famous "Rheingold", not only because

of their appearance but also because of their excellent performance. They reached a maximum speed of 75 mph (120 km/h) with a weight in working order of 92.3 tons. They were just over 69 feet (21.22 m) long over the buffers. The last engine of this class, No. 18478 was taken out of service in July, 1960.

8393

The same model as 3093 but for two-rail D.C. operation (see page 35)

HAMO

The history of the railroad is the history of the steam locomotive

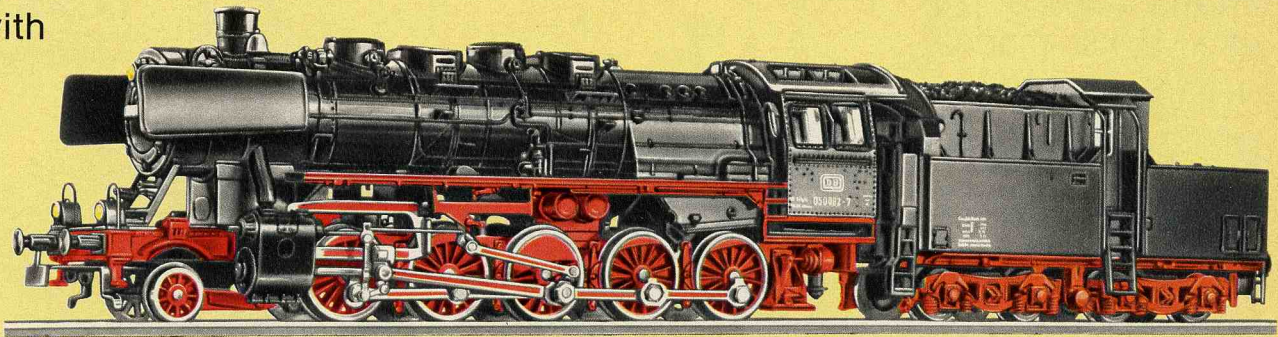

Heavy freight locomotive with cab tender



3084

Heavy freight locomotive with cab tender · A model of the German Federal Railways' Class 050 2-10-0 locomotive · 5 axles driven by concealed gears · 4 rubber tires · To obtain easy running on curves, the frame is divided into two groups of driving wheels flexibly coupled together · Simulated Heusinger reversing gear · Remote control for

forward and reverse drive · Three working headlights · Mat black metal body with fine detailing · Die cast zinc frame · Coupling hook at front, automatic coupling with advance uncoupler (RELEX) on tender · Length over buffers 10 1/4" (26.1 cm) · **The locomotive is arranged to take the smoke unit 7226 (see page 74)**

⊙ = 7153  = 7164  = 60015

Because of its low axle load of only 15 tons, this freight locomotive, now known as Class 050, can also be used on branch lines. Over 3000 of them were built, nearly all the European locomotive works building some of them. In the sixties, an engineer's cab was incorporated in the tender of most of them which were still in service. Their range of application was thereby increased. The maximum speed was 50 mph (80 km/h), 1625 HP being de-

veloped. Length over buffers 74 feet (22.94 m).

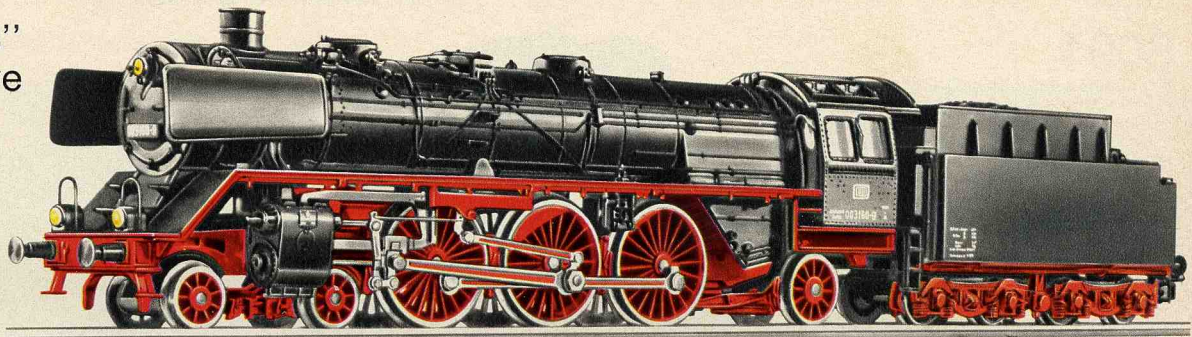

German Federal Railways' "BR 003" express locomotive



3085

Express locomotive with tender · A model of the German Federal Railways' Class 003 4-6-2 locomotive · 3 axles driven by concealed gears · 2 rubber tires · Simulated Heusinger reversing gear · Remote control for forward and reversing drive · Three working headlights · Very finely detailed mat black metal body · Die

cast zinc frame · Automatic coupling with advance uncoupler (RELEX) on tender · Length over buffers 11" (27.7 cm) · **The locomotive is arranged to take the smoke unit 7226 (see page 74)**

⊙ = 7152  = 7164  = 60015

The former German State Railways used about 300 locomotives of the Class 03 (now called Class 003) as a somewhat lighter variant of Class 01, for pulling express trains on tracks which were not approved for axle loads of 20 tons. They developed 1980 HP, giving a top speed of 80 mph (130 km/h). Coupled to the tender T 32, the overall length over the buffers was 78 feet (23.90 m).



8385

The same model as 3085 but for two-rail D.C. operation (see page 35)

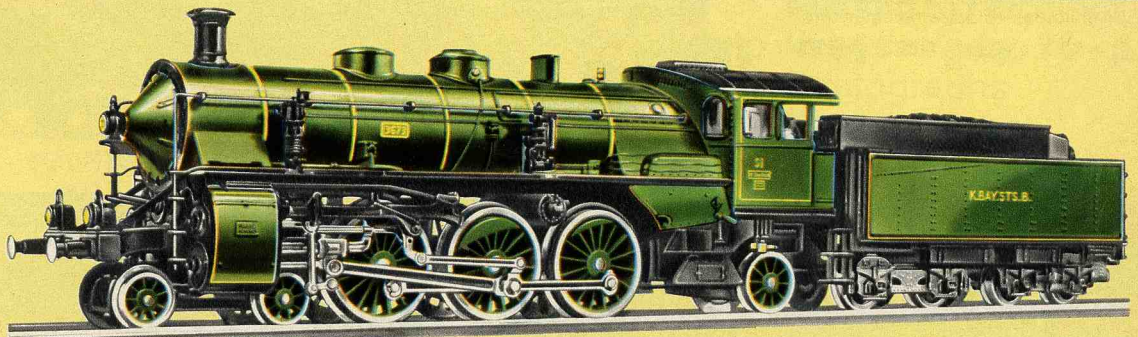

Express locomotive with tender "S 3/6"



3092

Express locomotive with tender · A model of the former Royal Bavarian Railways' Class S 3/6 series I 4-6-2 locomotive · 3 driven axles · 2 rubber tires · Simulated Heusinger reversing gear · Remote control for forward and reverse drive · Three working headlights · Dark green metal body with

yellow boiler rings · Fairings at the engineer's cab · Very fine detailing of valves · Die cast zinc frame · Automatic coupling with advance uncoupler (RELEX) on the tender · Length over buffers 9 3/4" (24.9 cm) · **Arranged to take the smoke unit 7227 (see page 74)**

⊙ = 7152  = 7185  = 60015



8392



The same model as 3092 but for two-rail D.C. operation (see page 35)

The finest locomotives – reproduced by Märklin with loving care

The handsome "P 8" as a Märklin model

3098

Locomotive with tender · A model of the German Federal Railways' Class 38 4-6-0 locomotive · 3 driven axles · 2 rubber tires · Simulated Heusinger reverse gear · Remote control for forward and reverse drive · Three working headlights · Mat black metal body with detailed simulation of the valves on the boiler and in the engineer's cab · Die cast zinc frame · Trough shaped tender with two bogies · Coupling hook at front, automatic coupling with advance uncoupler (RELEX) on tender · Length over buffers 9 $\frac{3}{8}$ " (23.7 cm)

0 = 7152  = 7185  = 60015

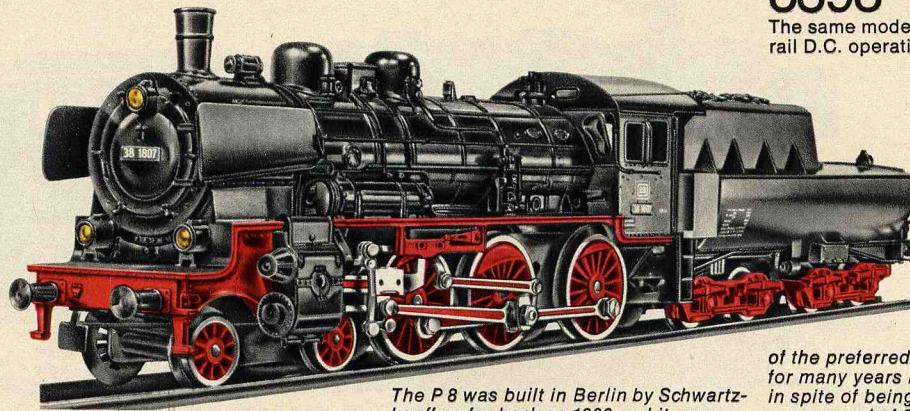

8398

The same model as 3098 but for two-rail D.C. operation (see page 35)



The P 8 was built in Berlin by Schwartzkopff as far back as 1906 and it was used by the Prussian State Railways for local and express services. Because of its reliability, it remained one



of the preferred types of locomotive for many years in some of the regions, in spite of being approved for a maximum speed of 63 mph (100 km/h) only. Altogether 3800 of these locomotives were built by a number of different firms.

Streamlined express locomotive

"03¹⁰"

3094

Streamlined express locomotive with tender · A model of the 4-6-2 Class 03¹⁰ locomotive · 3 driven axles · 2 rubber tires · Simulated Heusinger reversing gear · Remote control for forward and reverse drive · 2 working headlights · Mat black streamlined body with silver stripes · Detailed simulation of the cab and boiler valves · Die cast zinc frame · Automatic coupling with advance uncoupler (RELEX) on tender · Length over buffers 10 $\frac{3}{4}$ " (27.4 cm)

0 = 7152  = 7185  = 60015

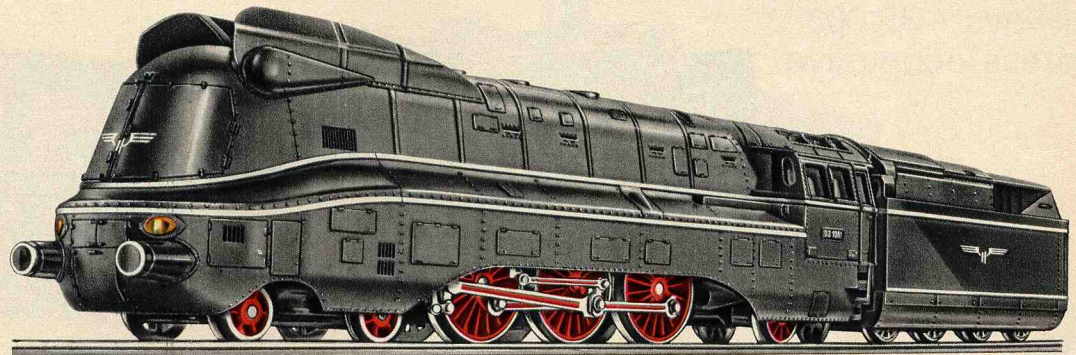



After streamlined fairings had proved themselves on other locomotives by reducing the wind resistance at high speeds, the Class 03¹⁰ locomotives with three-cylinder engines were put into service with streamlined fairings

in 1937. For easier maintenance, however, the driving gear was left uncovered. This class was developed as a lighter version of the Class 01, with an original axle load of 17 tons and a top speed of 85 mph (140 km/h).

"03¹⁰"—Dark red finish

3089

Streamlined express locomotive with tender · The same model as 3094 but with dark red streamlined body with silver stripes · Black wind deflectors

0 = 7152  = 7185  = 60015

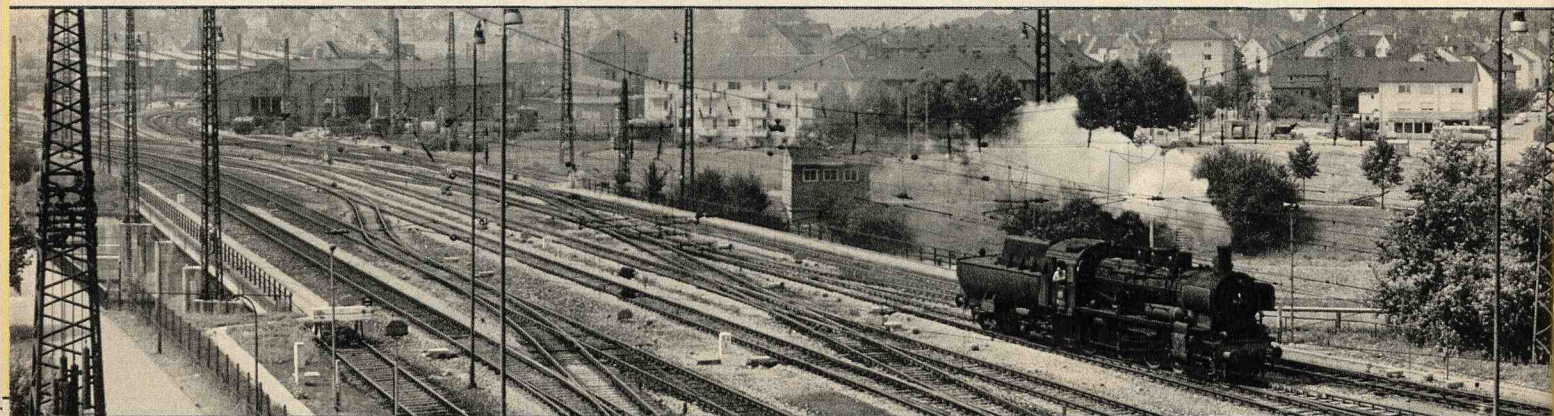
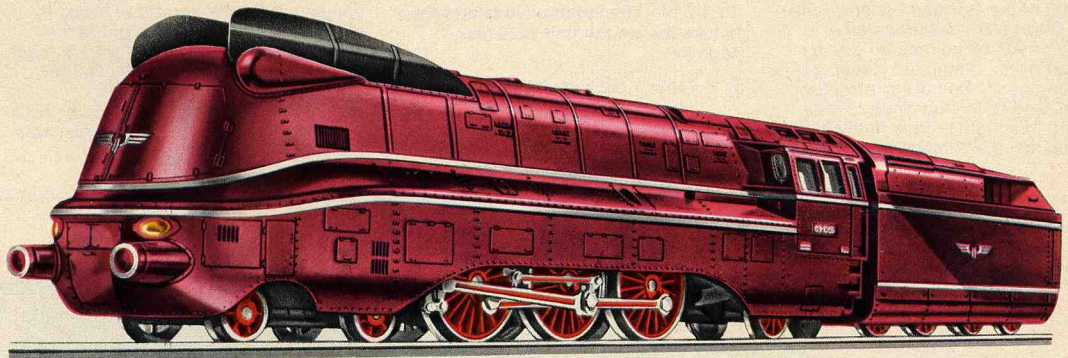

Märklin models are as reliable as the famous originals on which they are based

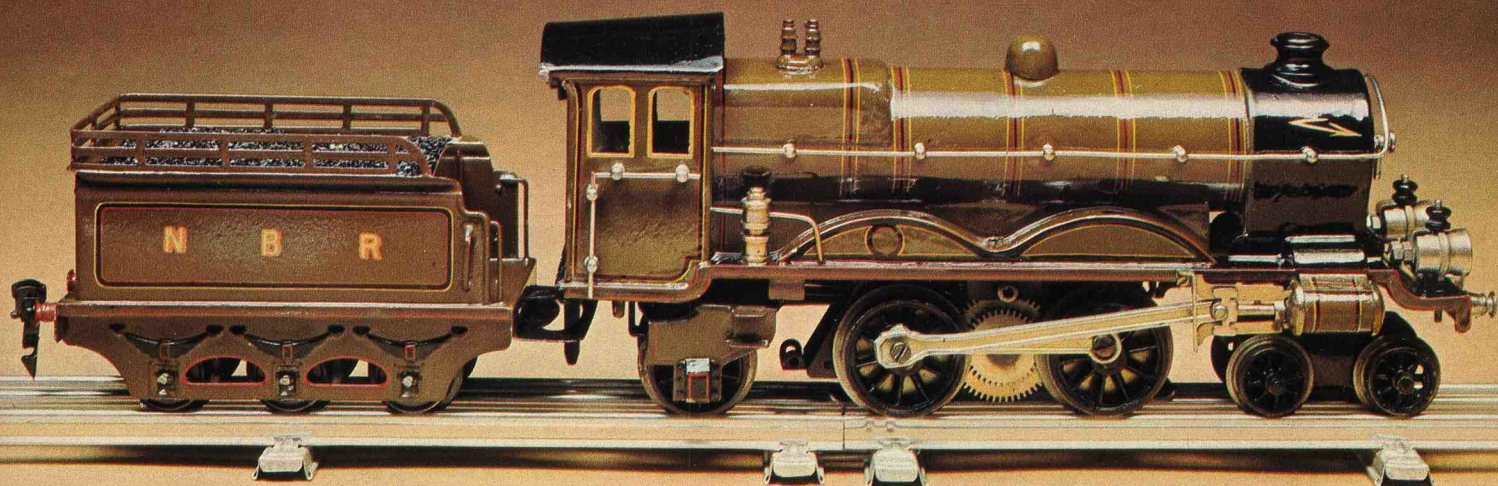

Märklin Old-timer: 0 gauge · CE 64/3020 · Year of construction 1926

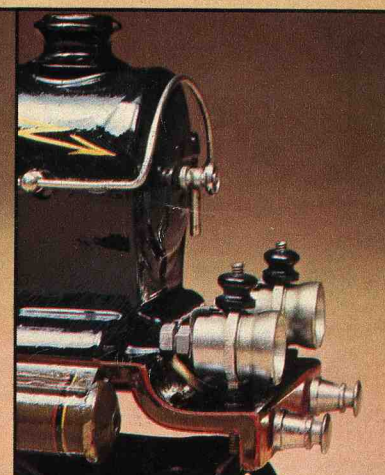
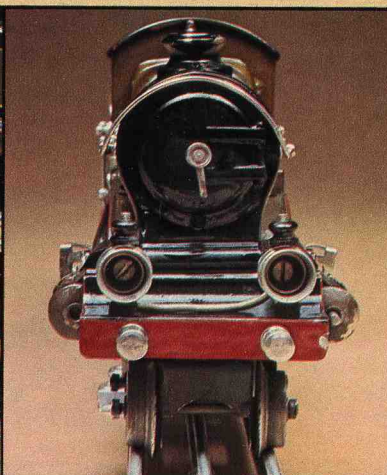
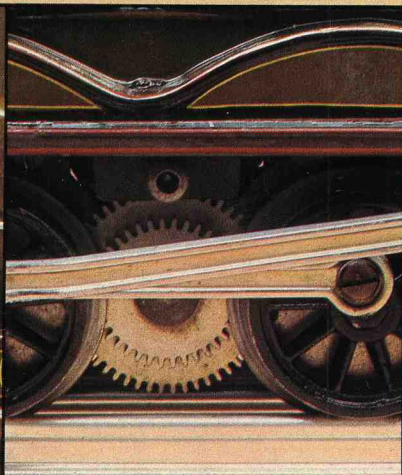
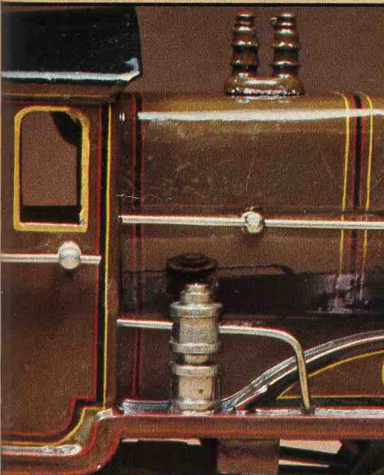

HAMO

HAMO locomotives are fitted for two-conductor DC operation. Reversal of direction is effected by reversing the polarity of the traction current. On electric locomotive types, the headlights change ends on reversing.

These models can be operated on any tracks conforming to NEM standards. A replacement set of couplings is supplied with each locomotive to enable rolling stock of other makes to be coupled up.

HAMO locomotives are made by Märklin.

Accessories for Märklin HO locomotives see page 74

- Pantographs
- Pairs of carbon brushes
- Oil bottles
- Smoke oil
- Reverser unit springs
- Rubber tires
- Current pick-up shoes
- Light bulbs

Märklin locomotives for two-rail D.C. operation are also available

Electric switching locomotive "EA 800"

3044

Electric locomotive · A model of a multi-system 0-6-0 industrial locomotive of type EA 800 · 3 driven axles · 2 rubber tires · Remote control for forward and reverse drive · Switch lever to permit selection of operation from overhead line or track contacts · Three working headlights at each end · Red plastic body · Single-bar pantographs mounted on roof · Die cast zinc frame · Finely detailed journal boxes · Coupling hook at each end · Length over buffers 4 1/2" (11.2 cm)

⊖ = 7154 ⊕ = 7185 ⚡ = 60015

Locomotives of this type were designed for heavy track and switching service on works' rail systems, and for transferring cars to mainline railroads. They can draw power from either the overhead lines or internal batteries. Maximum speed is approximately 35 mph (50 km/h). The locomotive with single-axle drive develops 39000 lbs. (19 500 kg) tractive force. It weighs 60 tons and is 35 feet (10.20 m) long.

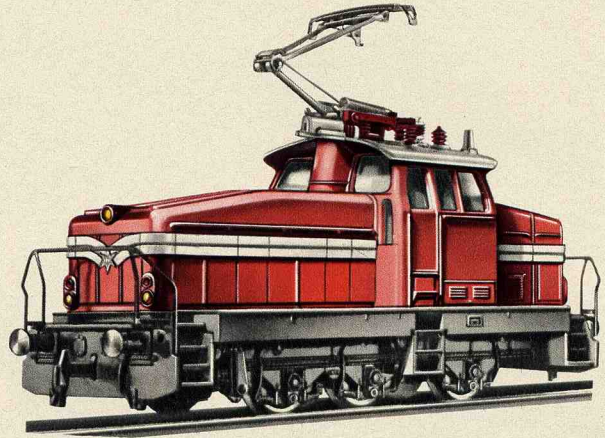

"194" Heavy electric freight locomotive

3022

Electric freight locomotive · A model of the German Federal Railways' Class 194 0-6-6-0 locomotive · 3 driven axles · 4 rubber tires · Remote control for forward and reverse drive · Three working headlights at each end · Switch lever for selecting operation from the overhead line or the track contacts · 2 spring-loaded pantographs on roof · Green, three-section metal body · Silver-colored roof · Windows inset in plastic frames · Automatic coupling with advance uncoupler (RELEX) at each end · Length over buffers 8 1/4" (21 cm)

⊖ = 7153 ⊕ = 7164 ⚡ = 60015

The Class 194 is the workhorse of the railways. The starting power of the six motors applies 6350 HP to the wheels. With a service weight of 120 tons, they have a maximum starting tractive force of 40 tons. They reach a top speed of only 56 mph (90 km/h) it is true, but on the other hand, even with the heaviest freight train, no gradient is too much for them. 124 of these 70 feet (18.60 m) long giants are in service on the German Federal Railways.



8322

HAMO

The same model as 3022 but for two-rail D.C. operation (see page 35)

Express locomotive "103"

3054

Electric express locomotive · A model of the German Federal Railways' 0-6-6-0 Class 103 locomotive · 3 driven axles · 4 rubber tires · Remote control for forward and reverse drive · Three working headlights at each end · Switch lever for selecting operation from the overhead line or the track contacts · Die cast zinc frame · Specially low centre of gravity · Plastic body in the TEE colors, beige and red · Aluminium-colored roof superstructure · Windows inset in plastic frames · 2 spring-loaded pantographs on the roof · Coupling hook at each end · Length over buffers 8 1/2" (21.9 cm)

⊖ = 7153 ⊕ = 7164 ⚡ = 60015

This is at present the most stylish and the most powerful, and the fastest of the German Federal Railways express electric locomotives. 62 feet (19.50 m) long, its six axles are driven by six motors developing nearly 9000 HP. Its service weight is 112 tons and the mighty tractive force of 32 t takes account of future requirements. On suit-

able tracks, expresses pulled by the "103" travel at maximum speeds of 125 mph (200 km/h). All the splendid features of the original are captured in the small Märklin model.



Electrical power gives the maximum pulling force

"141" The multipurpose electric locomotive

3034

Electric locomotive · A model of the German Federal Railways' 0-4-4-0 Class 141 locomotive · 2 driven axles · 4 rubber tires · Remote control for forward and reverse drive · Three working headlights at each end · Switch lever for selecting operation from the overhead line or the track contacts · 2 spring-loaded pantographs on the roof · Blue metal body · Silver-colored roof ·

Coupling hook with advance uncoupler at each end · Length over buffers 7" (17.5 cm)

⊙ = 7153 🚂 = 7164 💡 = 60015



3037

Electric locomotive · A model of the German Federal Railways' Class 141 · Similar to 3034, except that the body is green

The Class 141 has an in-service weight of 66.4 tons and a length of 50 feet (15.66 m). The 4 traction motors develop 3100 HP giving a maximum speed of 75 mph (120 km/h). It is used for passenger and freight services.

⊙ = 7153 🚂 = 7164 💡 = 60015

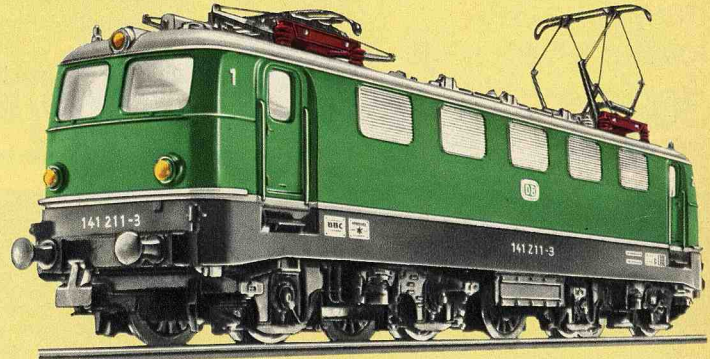

Electric express locomotive "110"

3039

Electric express locomotive · A model of the German Federal Railways' 0-4-4-0 Class 110 locomotive · 2 driven axles · 4 rubber tires · Remote control for forward and reverse drive · Three working headlights at each end · Switch lever for selecting operation from the overhead line or from track contacts · Blue metal body · Outstanding reproduction of all roof details · 2 spring-loaded pantographs on roof · Silver-colored roof · Windows inset in plastic frames ·

Coupling hook with advance uncoupler at each end · Length over buffers 7 1/8" (18.1 cm)

⊙ = 7153 🚂 = 7164 💡 = 60015

The electric locomotives of Class 110 were purchased by the German Federal Railways from 1956 onward. The 110 is used as an express locomotive with an authorised maximum speed of 90 mph (150 km/h). The Class 110 locomotive has 4 traction motors developing together about 5000 HP. The locomotive weighs 85 tons and its length is nearly 50 feet (16.44 m) over the buffers.

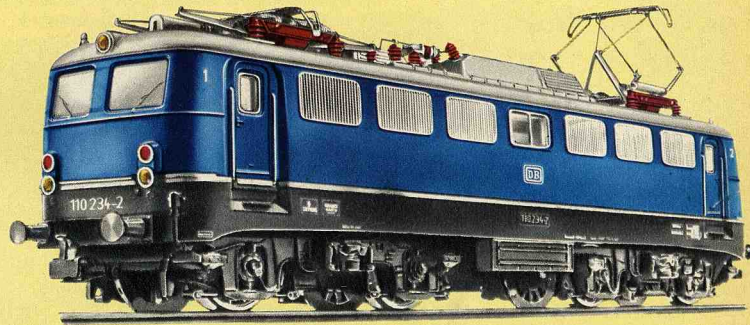

Uhrwerk- u. Dampf-Lokomotiven Eisenbahnwagen

1021 I Lokomotive, superfein, 4-achsige — Spur I — mit ausgezeichnetem, reguliertem Uhrwerk, mit 2 Federn und flachem Aufbau. Vor- und rückwärts-, langsam- und schnellfahrend. Extra stark und extra gross gebaut. Mit Tender

Dieses Modell in seiner Gesamtausführung besonders solid und fein, ist die Wiedergabe einer modernen erstklassigen Express-Lokomotive mit aussergewöhnlicher Zugkraft

1021 I Lokomotive, amerikan. Form — Ausführung wie zuvor

1022 II Lokomotive, Ausführung wie FE 1021 — Spur II — mit Tender

1022 II Lokomotive, amerikan. Form — Ausführung wie zuvor

21 I Dampflokomotive, superfein, 4-achsige — Spur I — vor- und rückwärts-, langsam- und schnellfahrend, automatisch abstellend, mit Kreuzkopfführung und patentierter Dampfheize, Sicherheitsventil, Wassergefährlose Heizmethode „Perfekt“

Extra stark

Diese Maschine, einer der schönsten, äusserst lehrreiches Modell. Der Kessel, welcher mit der Speisepumpe die während der Fahrt, und verbleibende Wasserstand im Kessel. Die Dampfheize zuverlässig. Der Abdampf-Gewinn noch erhöht. Die Spiritusflamme

Dampflokomotive, wie zuvor — Spur II — mit Tender No. 1801/II

Heizwagen, mit Dampfessel und Spiritusheizung, 2-achsige, hochfeine naturgetreue Lackierung — Spur I — Mit 4 Kupplungen und 50 cm Patentschlauch.

Die Dampfheizung von Eisenbahnzügen kann durch diese Neuheit auf reizende Weise nachgeahmt werden. Durch eine entsprechende Anzahl Kupplungen und Schläuche 1869 K u. S. kann der Dampf unterhalb der Wagen den ganzen Zug entlang geführt werden, um am Ende des Zuges zu entweichen

Kupplungen, am Puffer des Wagens zu befestigen

Patentschlauch, schwarz, zum Anschluss an die Kupplungen — per Meter

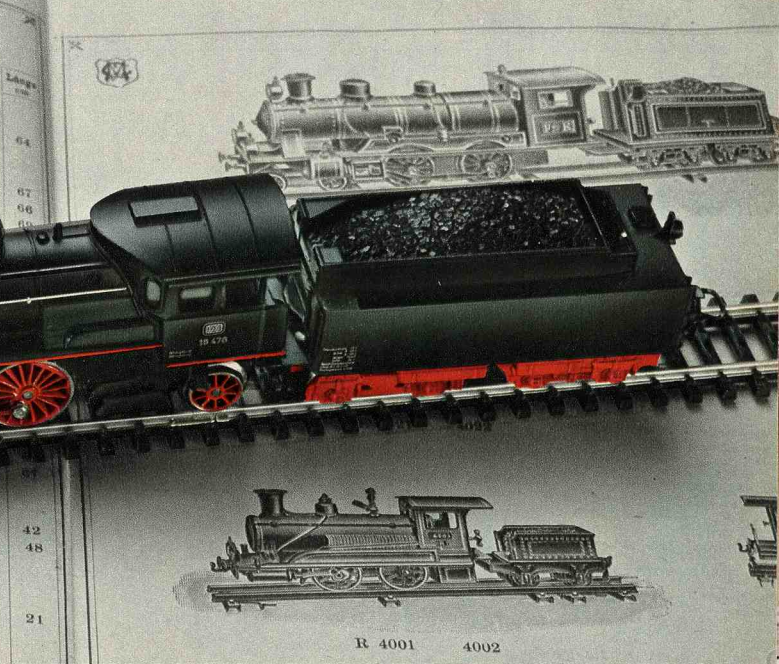



Faster, more powerful, cleaner.
Modern trains are pulled by electric locomotives

French high-power electric locomotive

3038

Electric locomotive · A model of the 0-4-4-0 Class BB 9200 locomotive of the French Railways (SNCF) · 2 driven axles · 4 rubber tires · Remote control for forward and reverse drive · 2 working headlights at each end · Switch lever for selection of operation from the overhead line or the track contacts · 2 spring-loaded pantographs on roof · Turquoise metal body · Coupling hook

with advance uncoupler at each end · Length over buffers 7" (18 cm)

⊙ = 7153  = 7164  = 60015

The French original of our model 3038 runs on certain stretches of the French Railways at a maximum speed of 100 mph (160 km/h). The locomotives of the Class BB 9200 have four traction motors together developing 5500 HP. Their weight is 80 tons.

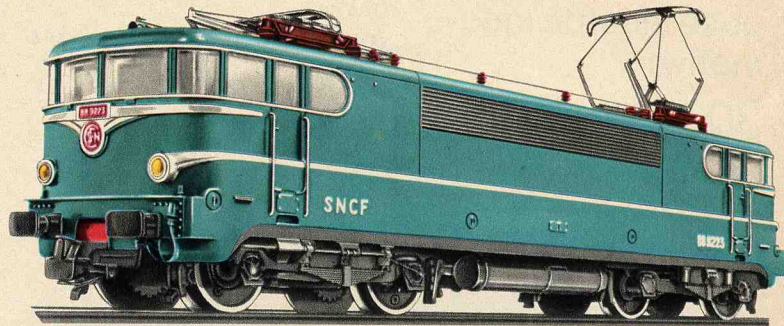



Italian electric locomotive

3035

Electric locomotive · A model of the Italian State Railways' 0-4-4-0 Class E 424 locomotive · 2 driven axles · 4 rubber tires · Remote control for forward and reverse drive · 2 working headlights at each end · Switch lever for selection of operation from overhead lines or track contacts · 2 spring-loaded pantographs on roof · Brown

metal body · Coupling hook with advance uncoupler at each end · Length over buffers 6 7/8" (17.5 cm)

⊙ = 7153  = 7164  = 60015

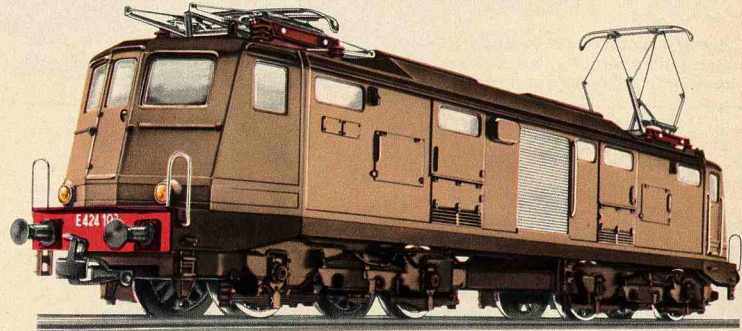



Austrian Federal Railways' multi-purpose locomotive

3041

Electric multi-purpose locomotive · A model of the Austrian Federal Railways' 0-4-4-0 Class 1043 locomotive · 2 driven axles · 4 rubber tires · Remote control for forward and reverse drives · Three working lights at each end · Switch lever for selection of operation from overhead lines or the track contacts · Red plastic body · Windows inset in plastic frames · 2 single-bar pantographs on roof · Die cast zinc frame

Coupling hook at each end · Length over buffers 6 7/8" (17.5 cm)

⊙ = 7153  = 7164  = 60015

After extensive trial runs with this locomotive, with was built by the Swedish firm ASEA, the Austrian Federal Railways acquired four of them initially. They were put into service under the designation Class 1043. The 16 2/3 c/s alternating current picked up from the overhead line is converted into direct current by thyristors. The four traction motors develop almost 5000 HP, which give the 52 feet (15.5 m) long engine weighing 77.4 tons a top speed of 84 mph (135 km/h).

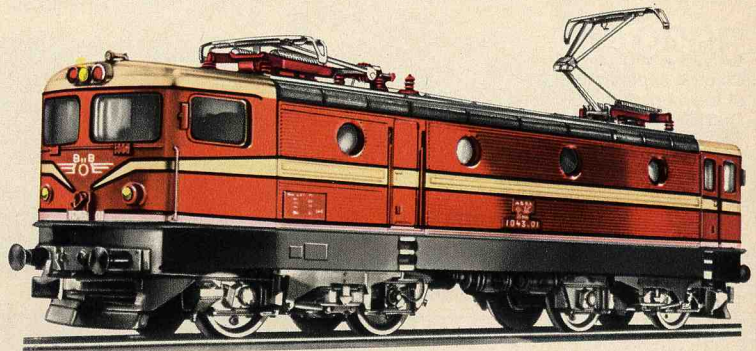



The Swiss Federal Railways' powerful multi-purpose locomotive

3050

Electric multi-purpose locomotive · A model of the Swiss Federal Railways' 0-6-6-0 Class Ae 6/6 locomotive · 3 driven axles · 4 rubber tires · Remote control for forward and reverse drive · Three working headlights at each end · Switch lever for selection of operation from the overhead line or the track contact · 2 spring-loaded pantographs on the roof · Green metal body · Silver-colored roof · Locomotive with the "Berne Canton" crest · Coupling hook at each end · Length 7 1/8" (20 cm) · Crests of the other Swiss cantons are supplied with this locomotive

The Swiss Federal Railways ordered the Ae 6/6 for international passenger and freight service. The locomotive's weight of 120 tons and the 6000 HP developed by its six motors gives it enormous starting and climbing power. The top speed is 80 mph (125 km/h). With all its giant power, it still has a particularly stylish appearance, which is reason enough for us to model it most accurately.

⊙ = 7153  = 7164  = 60015

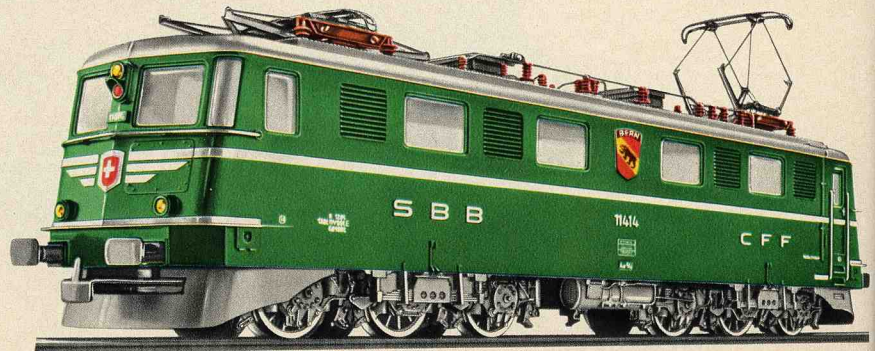



The "work-horse" with the best record in international competition

Swiss heavy electric freight locomotive "Crocodile"

This giant Swiss electric freight locomotive Be 6/8 on its eight axles, a real "King of the Mountains", is nicknamed "The Crocodile". It is undoubtedly the Swiss Railways' most impressive locomotive.

3015

Electric freight locomotive · A model of the Swiss Federal Railways' 2-6-6-2 Series Be 6/8 (Crocodile) locomotive · 6 driven axles · 2 rubber tires · Because of its articulated construction, it can easily negotiate curves of normal radius · Remote control for forward and reverse drive · Three working head-lights at each end with automatic change-over · Switch lever for selection of operation from overhead line or the track contacts · 2 spring-loaded pantographs on the roof · Automatic coupling with advance uncoupler (RELEX) at each end · Length over buffers 10 1/4" (26 cm)

0 = 7153  = 7175  = 60000

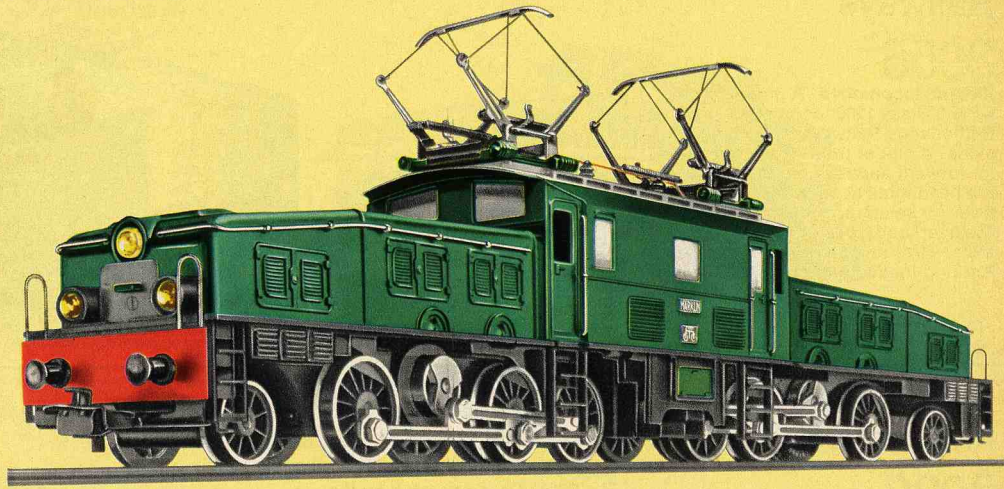

Märklin Old-timer: I gauge · HS 65/13021 · Year of construction 1929

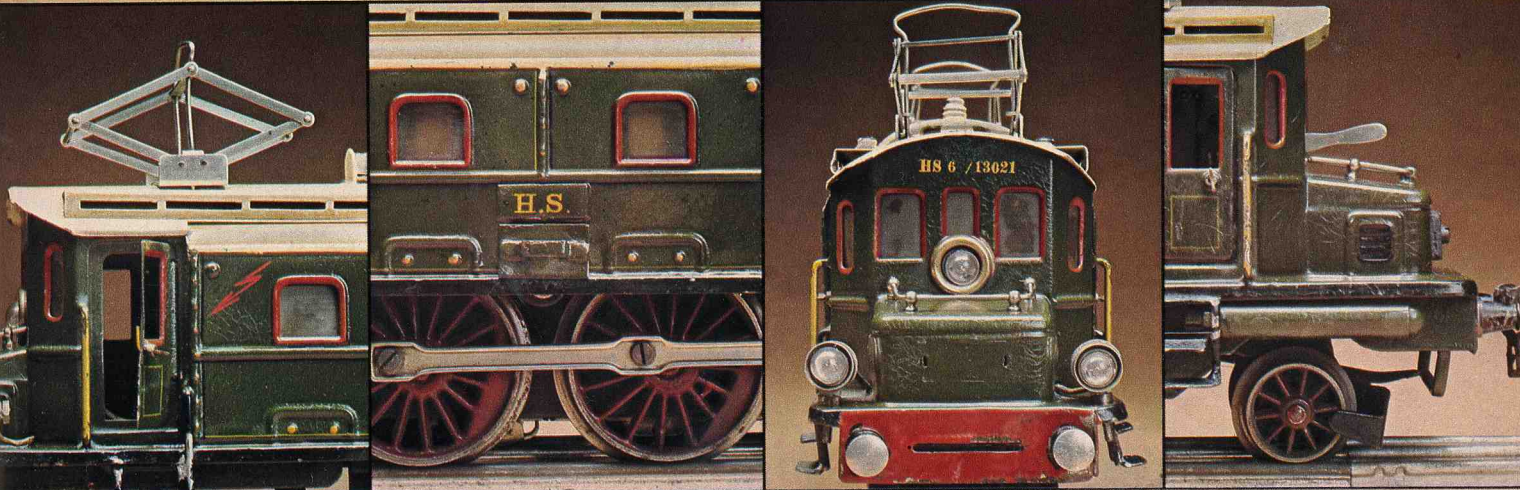

The articulated "Crocodile": king of the mountains on real railways, a model much sought after by connoisseurs

Electric locomotive of the Netherlands Railways

3055

Electric locomotive · A model of the 0-6-6-0 Class 1200 locomotive of the Netherlands Railways (NS) · 3 driven axles · 4 rubber tires · Remote control for forward and reverse drive · 3 working headlights at each end · Switch lever for selection of operation from the overhead lines or the track contacts · Grey and yellow metal body · 2 spring-loaded pantographs on the

roof · Windows inset in plastic frames · Coupling hook at each end · Length over buffers 7³/₄" (19.6 cm)

⊖ = 7154 ⊞ = 7164 ⊕ = 60015

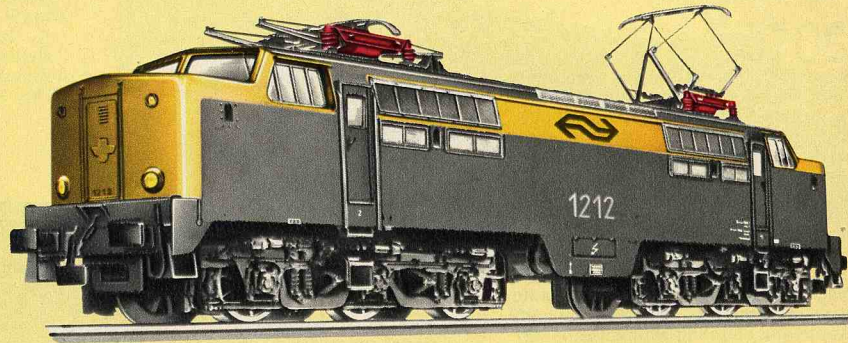

Swedish electric locomotive

3030

Electric locomotive · A model of the Swedish State Railways' (SJ) 2-8-2 Class Da locomotive · 3 driven axles · Jackshaft driven through gears · 2 rubber tires · Remote control for forward and reverse drive · Three working headlights at each end · Switch lever for selection of operation from overhead line or from track contacts · 2 spring-loaded pantographs on roof · Brown metal body · Die cast zinc frame · Automatic coupling with ad-

vance uncoupler (RELEX) at each end · Length over buffers 5³/₄" (14.7 cm)

⊖ = 7153 ⊞ = 7185 ⊕ = 60015

The Class Da is operated by the Swedish State Railways (Statens Järnvägar) as the standard electric locomotive for passenger and freight service. Since these locomotives have only one motor and the axle load at 15 or 17 tons is low, they are fitted with connecting rod drive. This avoids the "running away" of individually driven axles when starting from rest.



Interesting Swedish multi-purpose locomotive

3043

Electric multi-purpose locomotive · A model of the Swedish State Railways' 0-4-4-0 Class Rc locomotive · 2 driven axles · 4 rubber tires · Remote control for forward and reverse drive · 4 working lights at each end · Switch lever for selection of operation from the overhead line or the track contacts · Orange-colored plastic body · Windows inset in plastic frames · 2 spring-loaded

pantographs on roof · Die cast zinc frame · Coupling hook at each end · Length over buffers 6⁷/₈" (17.5 cm)

⊖ = 7153 ⊞ = 7164 ⊕ = 60015

In these engines of very advanced design, alternating current at 16²/₃ c/s is taken from the overhead lines and is converted by transistors into direct current which drives the four traction motors developing a total of almost 5000 HP. The locomotive, almost 52 feet (15.50 m) long over the buffers, weighs 76 tons and reaches 84 mph (135 km/h).

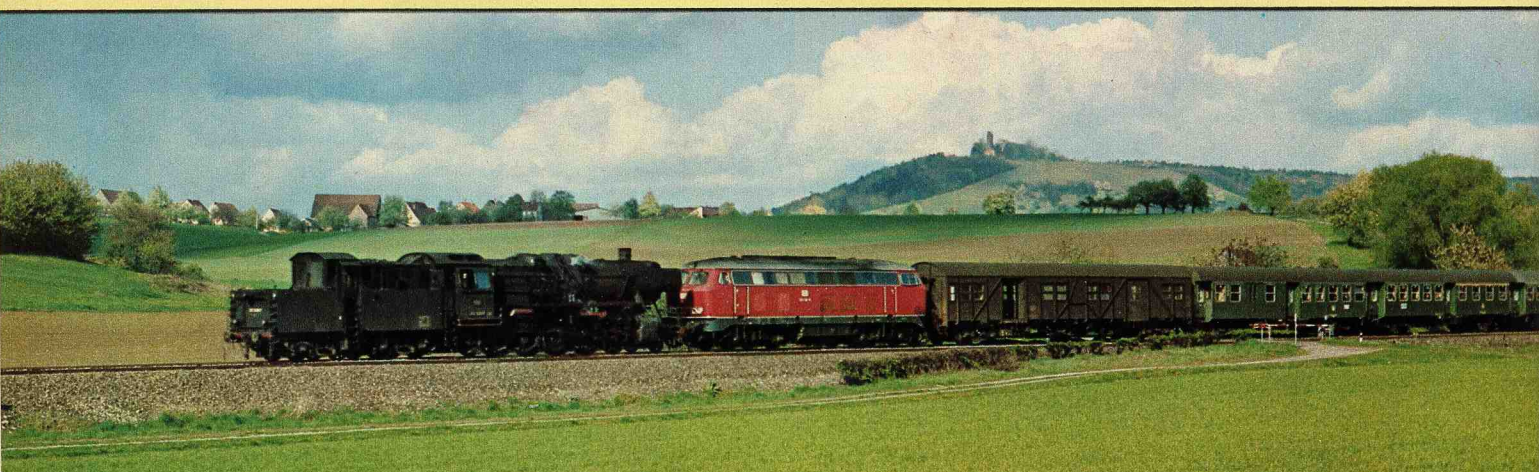
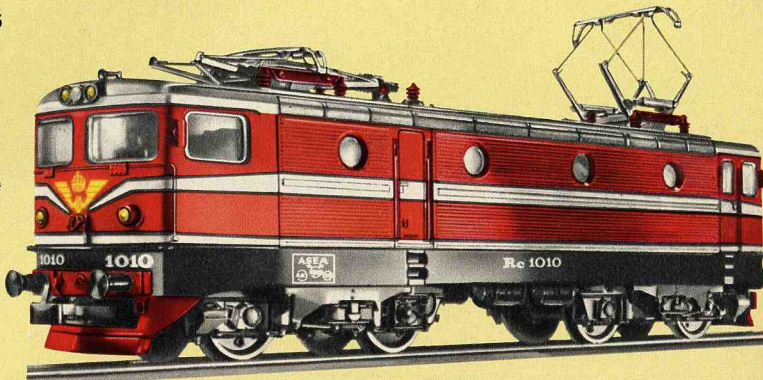

Märklin HO - the model railway with most fans throughout the world.

Diesel-hydraulic locomotive "DHG 500"

3078

Diesel locomotive · A model of 0-6-0 industrial locomotive known as the DHG 500 type · 3 driven axles · 2 rubber tires · Remote control for forward and reverse drive · Three working headlights at each end · Blue plastic body with decorative silver-colored bands · Die cast zinc frame · Coupling hook at each end · Length over buffers 4³/₈" (11.2 cm)

⊖ = 7154 🚂 = 7185 🔦 = 60015

These "small" diesel engines with hydraulic transmission nevertheless measure about 40 feet (10–11 m) long and have several hundred horsepower "under their hoods". The heavily-loaded gears in particular are especially robust, so that these locomotives can be used for long periods without significant maintenance work. These locomotives, which are typical of industrial locomotives (Märklin model 3078, 3080), have windows low down in the front side panels of the engineer's cab, allowing a clear view of the buffers for accurate switching.

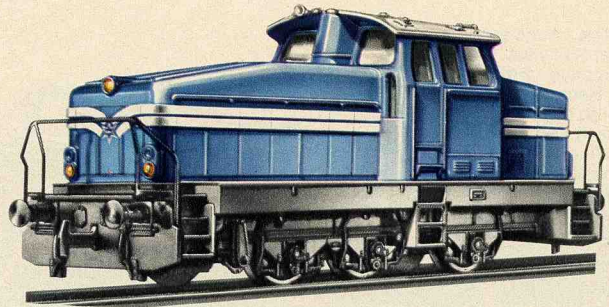

Industrial locomotive

3080

Diesel locomotive · A model of a 0-6-0 industrial locomotive · 3 driven axles · 2 rubber tires · Remote control for forward and reverse drive · Yellow plastic body with dark decorative stripes · Die cast zinc frame · Coupling hook at each end · Length over buffers 4³/₈" (11.2 cm)

⊖ = 7154 🚂 = 7185



Diesel-hydraulic switching locomotive "260" with Märklin TELEX coupling

3065

Diesel locomotive · A model of the German Federal Railways' 0-6-0 Class 260 locomotive · 3 driven axles · 2 rubber tires · Remote control for forward and reverse drive · Three working headlights at each end · Red plastic body · Windows inset in plastic frames · Die cast zinc frame · Märklin TELEX coupling

pling at each end · Length over buffers 4³/₄" (12 cm)

⊖ = 7153 🚂 = 7185 🔦 = 60010

TELEX, see page 31

With coupling hook

3064

Diesel locomotive · A model of the German Federal Railways' Class 260 locomotive · Similar to 3065 but without Märklin TELEX coupling · Coupling hook with advance uncoupler at each end

⊖ = 7153 🚂 = 7185 🔦 = 60010

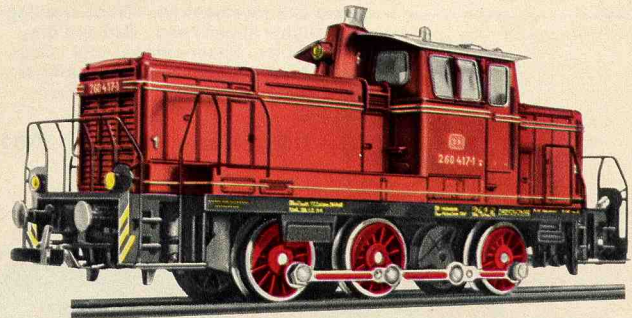

Diesel-hydraulic locomotive "212"

3072

Diesel locomotive · A model of the German Federal Railways' 0-4-4-0 Class 212 locomotive · 2 driven axles · 4 rubber tires · Remote control for forward and reverse drive · Three working headlights at each end · Die cast zinc frame · Red plastic body · Narrow front and rear ends to scale · Windows inset in plastic frames · Automatic coupling with advance uncoupler (RELEX) at each end · Length over buffers 5¹/₂" (14.1 cm) · A suitable positioning of the motor has enabled the front and rear

ends of model 3072 to be kept narrow as on the original

⊖ = 7154 🚂 = 7164 🔦 = 60010

The 212 is a multi-purpose diesel locomotive, 40 feet (12 m) long and weighing 63.2 tons in service order. The new types develop 1350 HP, which is transmitted through universal driveshaft to the 4 axles arranged in two bogies. In order to use the tractive force of the powerful motor to meet requirements for passenger and freight service, a dual-ratio gear is provided which can be operated from the cab. In low gear the locomotive has the maximum tractive force but the top speed is then only 40 mph (65 km/h), while in high gear it reaches 65 mph (100 km/h).

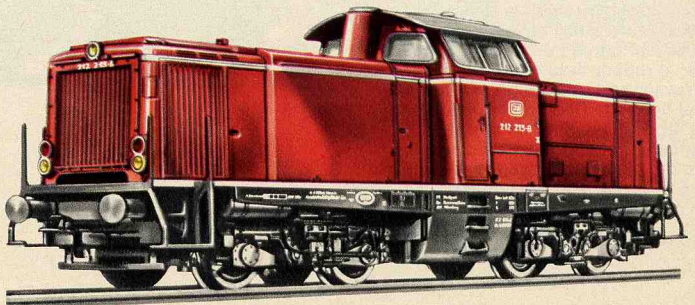

Diesel-hydraulic locomotives for precise marshalling operations

Diesel locomotive "216"

The Class 216 diesel locomotive is used for mainline service over medium distances. With full fuel tank it weighs 79 tons. It develops 1900 HP and reaches a maximum speed of 75 mph (120 km/h).

3075

Diesel locomotive · A model of the German Federal Railways' 0-4-4-0 Class 216 locomotive · 2 driven axles · 4 rubber tires · Remote control for forward and reverse drive · Three working headlights at each end · Red and grey plastic body · Windows inset in plastic frames with simulated windscreen wipers · Die cast zinc frame · Automatic coupling with advance uncoupler (RELEX) at each end · Length over buffers 7 1/8" (18.2 cm)

⊖ = 7154  = 7164 ⚡ = 60015

HAMO

8375

The same model as 3075 but for two-rail D.C. operation (see page 35)

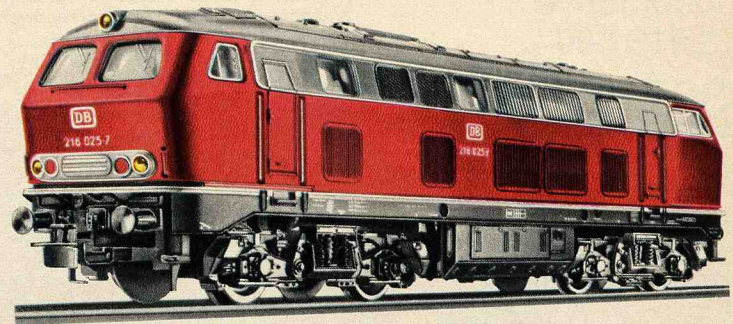

3074 **new**

Diesel locomotive · A model of the German Federal Railways' Class 216 locomotive · Similar to 3075 but with turquoise-ivory colored body

⊖ = 7154  = 7164 ⚡ = 60015

new

8374

The same model as 3074 but for two-rail D.C. operation (see page 35)

HAMO

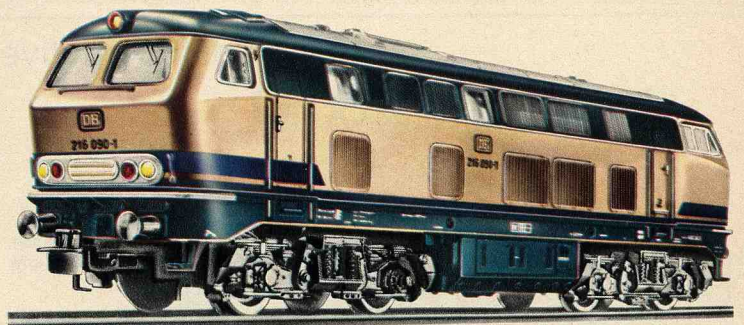

Diesel hydraulic express locomotive "220"

3021

Diesel locomotive · A model of the German Federal Railways' 0-4-4-0 Class 220 locomotive · 2 driven axles · 4 rubber tires · Remote control for forward and reverse drive · Three working headlights at each end · Red and grey metal body · Silver-colored roof · Coupling hook with advance uncoupler at each end · Length over buffers 8 1/4" (21 cm)

⊖ = 7154  = 7183 ⚡ = 60010

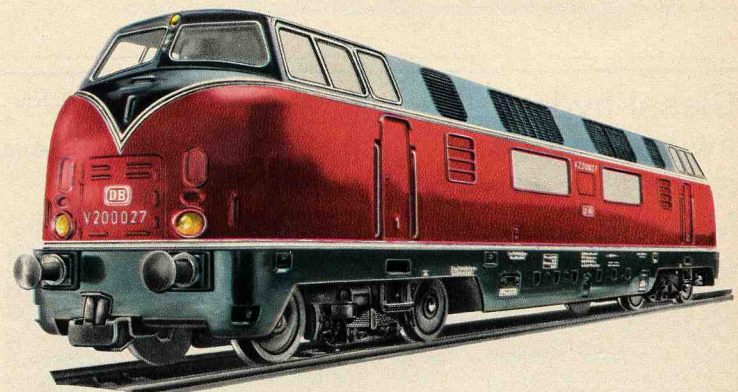

American "F 7" diesel locomotive of the Atchison Topeka and Santa Fé Railway

3060

Diesel locomotive · A model of the 0-4-4-0 American Type F 7 locomotive, built by the Electromotive Division of General Motors for the Atchison Topeka and Santa Fé Railway · 2 driven axles · 4 rubber tires · Remote control for forward and reverse drive · Scale model lighting · Red and silver-colored metal body · Coupling hook with advance uncoupler at cab end · Automatic coupling with advance uncoupler (RELEX) at rear end · Length 6 7/8" (17.5 cm)

⊖ = 7154  = 7185 ⚡ = 60015

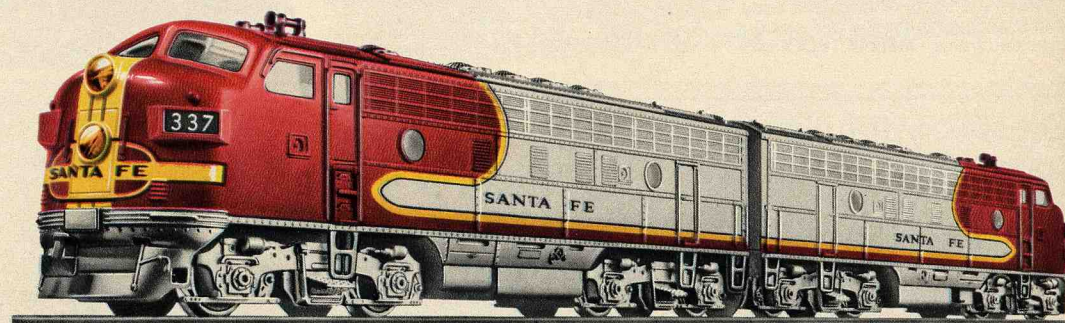

4060

Supplementary section, unpowered · Matching the diesel locomotive 3060 · Scale model lighting · Red and silver-colored metal body · Coupling hook with advance uncoupler at cab end · Length 6 7/8" (17.5 cm)

 = 7185 ⚡ = 60015

Not all lines are electrified

Belgian Railways' multi-purpose diesel locomotive

3066

Diesel locomotive · A model of the Belgian State Railways' (NMBS/SNCB) 0-6-6-0 Class 204 locomotive · 3 driven axles · 4 rubber tires · Remote control for forward and reverse drive · Three working headlights at each end · Green metal body · Black roof · Windows inset in plastic frames · Coupling hook at each end · Length over buffers 8" (20.5 cm)

⊖ = 7154 ⊞ = 7164 ⊗ = 60015

The Belgian multi-purpose diesel locomotive, Class 204, has diesel-electric drive. Developing 1750 HP, it is engaged in hauling light freight trains, as well as local and express passenger trains, reaching a maximum speed of about 87 mph (140 km/h).



Danish Railways' diesel-electric locomotive

3067

Diesel locomotive · A model of the Danish State Railways' (DSB) 0-6-6-0 Class My 1100 locomotive · 3 driven axles · 4 rubber tires · Remote control for forward and reverse drive · Three working headlights at each end · Red and brown metal body · Grey roof · Windows inset in plastic frames · Coupling hook at each end · Length over buffers 8" (20.5 cm)

⊖ = 7154 ⊞ = 7164 ⊗ = 60015

The Danish State Railways Class My 1100 multi-purpose locomotive has diesel-electric drive, i.e. the current for the tractor motors situated on the axles is produced by generators on the locomotive, the generators being driven by diesel engines. This type of locomotive is very similar to the Belgian Class 204.



Norwegian Railways' multi-purpose diesel-electric locomotive

3068

Diesel locomotive · A model of the Norwegian State Railways' (NSB) 0-6-6-0 Class Di 3 locomotive · 3 driven axles · 4 rubber tires · Remote control for forward and reverse drive · Three working headlights at each end · Red and brown metal body · Silver-colored roof and roof fittings · Windows inset in plastic frames · Coupling hook at each end · Length over buffers 8" (20.5 cm)

⊖ = 7154 ⊞ = 7164 ⊗ = 60015

Diesel operation is being increasingly used on the Norwegian State Railways' lines which are not yet electrified. The locomotive on which our model is based is known as Class Di 3. Its 1900 HP motor gives it a top speed of 63 mph (100 km/h). Apart from the roof fittings, its relationship to the Belgian Class 204 and the Danish Class My 1100 is unmistakable.



Diesel locomotives are indispensable

“TEE” Express train

3071

Three-unit TEE express train · A model of the Netherlands-Swiss TRANS EUROP EXPRESS train, consisting of a locomotive, a combined first-class and dining coach and a spacious first-class compartment coach with engineer's section · The model is 27 1/2" long (70 cm)

Locomotive: 3 driven axles · 4 rubber tires · Remote control for forward and reverse drive · Mat black die cast zinc frame · Plastic body in the TEE colors, beige and red · Grey roof · Windows inset in plastic frames

Dining coach and engineer's coach: each with 2 bogies like the originals · Plastic body in the TEE colors, beige and red · Grey roof · Windows inset in plastic frames

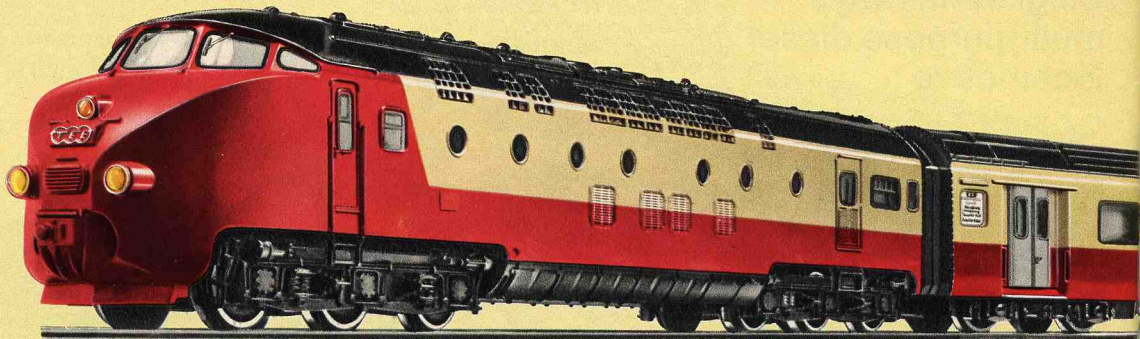

Special couplings connect the 3 units very close together · Specially tightly closing covers on the passages between coaches · Three headlights and two red taillights at each end of the train · A current pick-up shoe at

each end of the train, the front one in the direction of travel picking up the current

⊖ = 7154 ⊞ = 7164 ⚡ = 60015 w
 ⊞ = 7175 ⚡ = 60001 r

Railbus with trailer

3016

Railbus · A model of the German Federal Railways' type 795 unit · 1 driven axle · 2 rubber tires · Remote control for forward and reverse drive · Three working headlights at each end · Interior lighting · Red plastic body · Die cast zinc frame · Symmetrical special coupling at each end for close coupling the cars together · Length over buffers 5 3/4" (14.7 cm)

⊖ = 7153 ⊞ = 7164 ⚡ = 60010

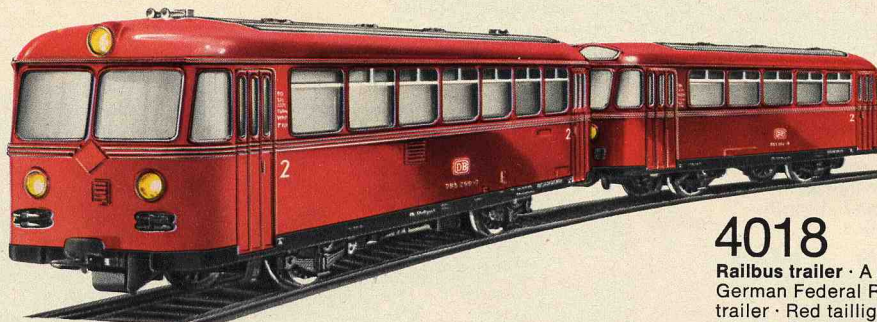

4018

Railbus trailer · A model of the German Federal Railways' type 995 trailer · Red taillights at each end · Interior lighting · Red plastic body · Symmetrical special coupling to fit railbus only · Length over buffers 4 3/4" (12 cm)

⊞ = 7175 ⚡ = 60010

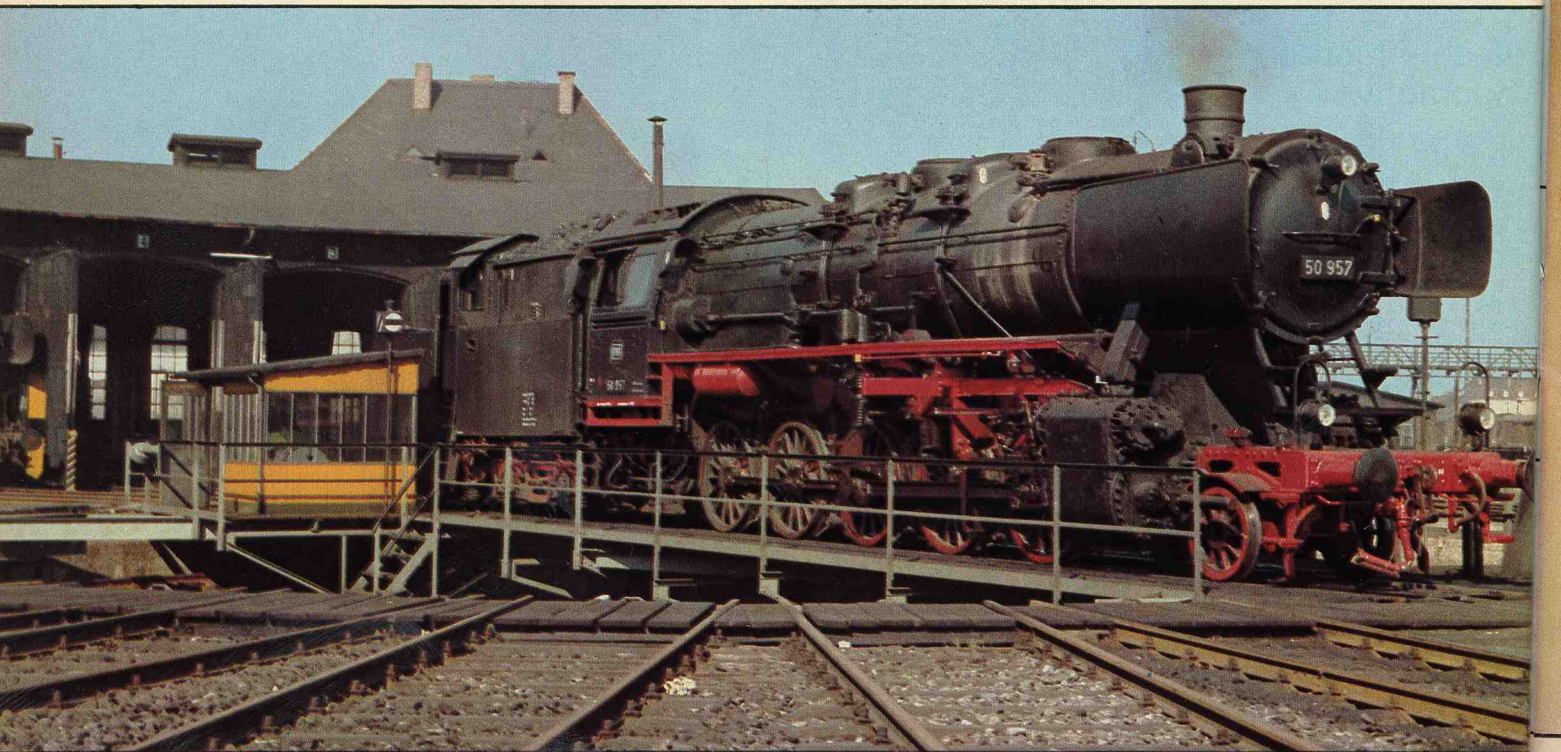

Precision-made Märklin models of multiple-unit trains

TEE TRANS EUROP EXPRESS



4071

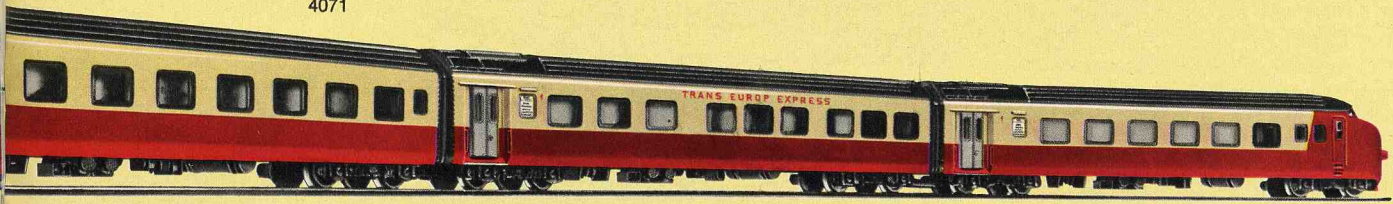

4071

TEE compartment coach · 1st class · 2 bogies true to the original · Grey roof · Windows inset with plastic frames · Movable covers for the corridor between coaches at each end · Special coupling fitting TEE trains only · Length 9¹/₄" (23.3 cm)

Five complete trains of the Netherlands-Swiss TRANS EUROP EXPRESS are now in service, operating between Zürich and Amsterdam as the TEE "Edelweiss". Mostly they consist of four coaches. Three powerful diesel engines, developing together 2300 HP, give the train a speed of 87¹/₂ mph (140 km/h). The windows in these trains do not open since all the coaches are fully airconditioned. As on all TEE trains there are only first class

coaches, providing 114 seats. The diner section can seat 32.

The TEE train illustrated consists of the three-part unit 3071, which has been supplemented by the coach 4071 to bring it up to the composition customary in service. The length of the four-unit train is 36³/₄" (93.5 cm).



Märklin Old-timer: I gauge constructed in the years 1927—1937

TEE trains link the people and cities of Europe

TEE coaches with interior fittings

We illustrate here the "show pieces" of the German Federal Railways, the TEE coaches. They are the best equipped, the most comfortable and certainly the most handsome of the Federal Railways' coaches.

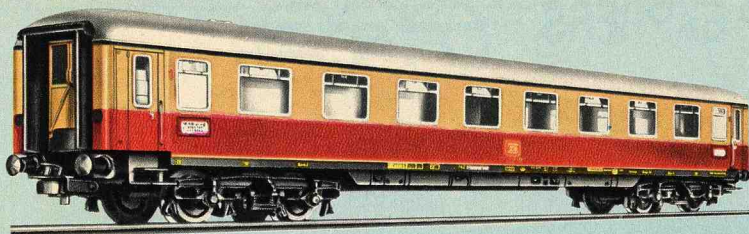

4085

TEE compartment coach · 1st class · A model of the German Federal Railways' type Avm · Windows inset in plastic frames · **Interior fittings** with side corridor · Length 9 1/2" (24 cm) · Arranged to take the interior lighting set 7320 (see page 75)

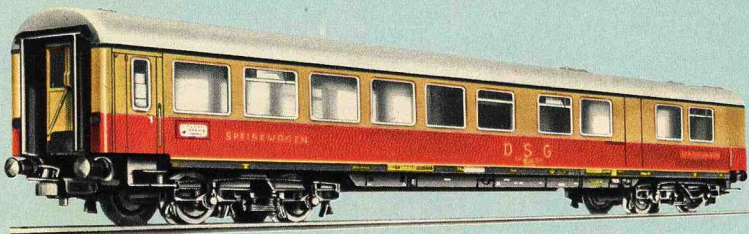

4087

TEE dining car · A model of the German Federal Railways' type WRm · Windows inset in plastic frames · **Interior fittings**, divided into kitchen and dining sections · Length 9 1/2" (24 cm) · Arranged to take interior lighting set 7320 (see page 75)



4089

TEE compartment coach · Similar to coach 4085 but with current pick-up, fittings for the interior lighting and taillights

 = 7175  = 60015

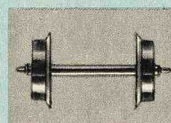
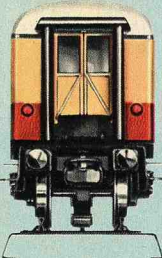

7589

Märklin-HAMO for two-rail D.C. operation

Set of wheels · Comprising 4 axle sets · For converting the TEE for two-rail D.C. operation

4090

TEE observation coach · 1st class · A model of the German Federal Railways' type ADm · Windows inset in plastic frames · **Interior fittings** · Observation dome of transparent plastic · Length 9 1/2" (24 cm) · Arranged to take interior lighting set 7322 (see page 75)

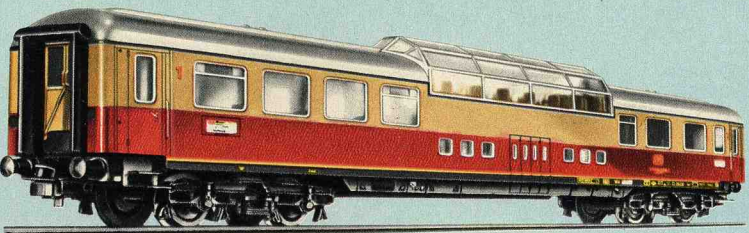



Local passenger service coaches of the German Federal Railways with interior fittings



new 4077

Local passenger service coach · With baggage compartment and engineer's cab · 2nd class · A model of the German Federal Railways' type BDnf · Stainless steel-colored coach body with peacock-eye pattern · **Interior fittings** · Windows with plastic frames · Roof with klaxon dummy · Headlights at the cab end · Length 9 1/2" (24 cm) · Arranged to take interior lighting set 7077 (see page 75)

 = 7175  = 60000

4082

Local passenger service coach · 2nd class · A model of the German Federal Railways' type Bnb · Stainless steel-colored coach body with peacock-eye pattern · **Interior fittings** · Windows in plastic frames · Length 9 1/2" (24 cm) · Arranged to take interior lighting set 7077 and current pick-up shoe 7198 (see page 75)



4083

Local passenger service coach · 1st and 2nd class · A model of the German Federal Railways' type ABnb · Stainless steel-colored coach body with peacock-eye pattern · **Interior fittings** · Windows with plastic frames · Length 9 1/2" (24 cm) · Arranged to take interior lighting set 7077 and current pick-up shoe 7198 (see page 75)



TEE coach with interior fittings, interior lighting and observation dome – every detail is fascinating.

4095

TEE compartment coach · 1st class · Model of the German Federal Railways' type Avm · Plastic coach body · **Interior fittings** with side corridor · Windows inset in plastic frames · Length 10⁵/₈" (27 cm) · Arranged for interior lighting set 7325 (see page 75)

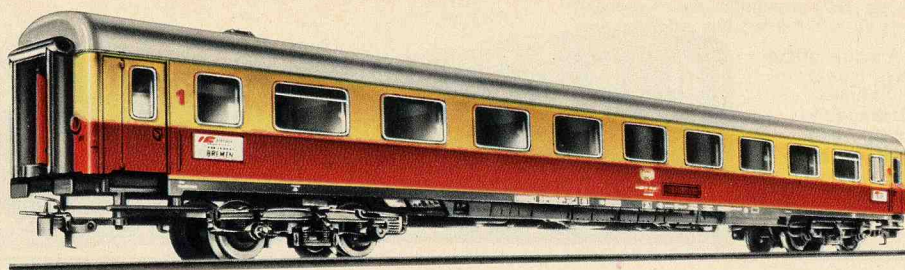

4096

TEE open-interior coach · 1st class · A model of the German Federal Railways' type Apm · Plastic coach body · **Interior fittings**, seats arranged two on one side, one on other side of central gangway · Windows inset in plastic frames · Length 10⁵/₈" (27 cm) · Arranged to take interior lighting set 7325 (see page 75)

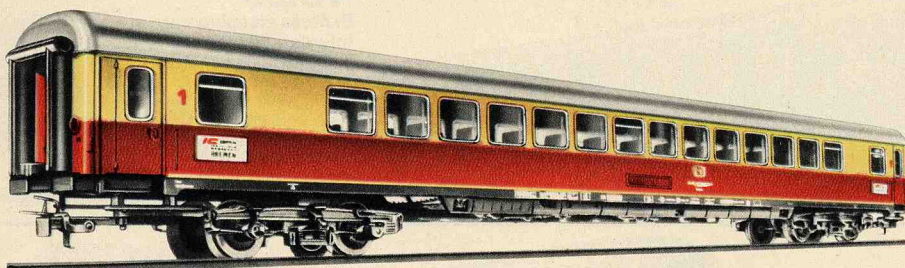

4097

TEE dining car · A model of the German Federal Railways' type WRm · Plastic coach body · **Interior fittings**, divided into kitchen and dining sections · Windows inset in plastic frames · Length 10⁵/₈" (27 cm) · Arranged to take interior lighting set 7325 (see page 75)

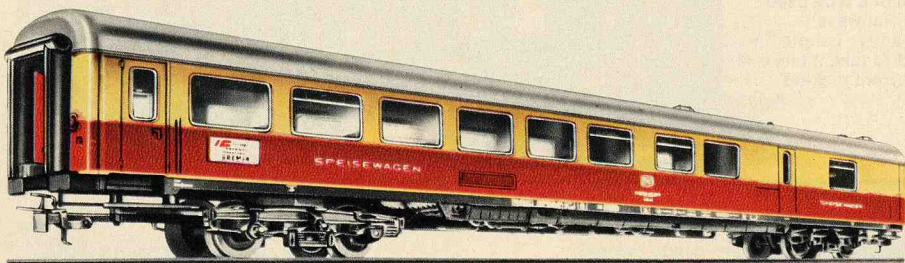

4099 **new**

TEE observation coach · 1st class · A model of the German Federal Railways' type ADm · Plastic coach body · **Interior fittings**, divided into bar, seating compartment and raised row of seats · Observation dome in transparent plastic · Windows inset in plastic frames · Length 10⁵/₈" (27 cm) · Arranged to take interior lighting set 7325 (see page 75)

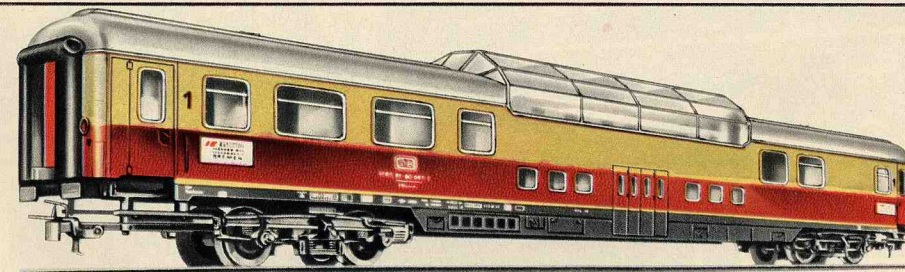

4074 **new**

Passenger train-car carrier · A model of the German Federal Railways' type DDm 915 · Loaded with 8 WIKING miniature cars · Length 10³/₈" (26.4 cm)

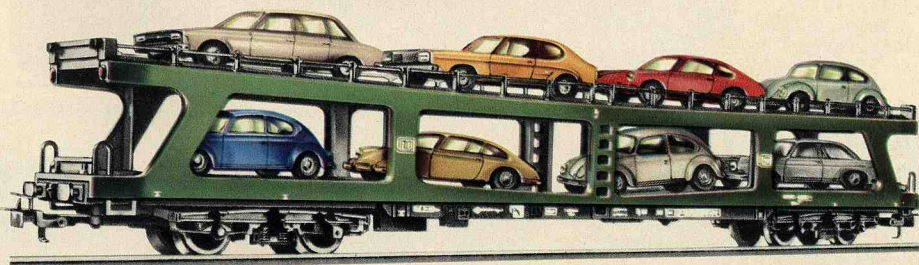

4084 **new**

Passenger train-car carrier · A model of the German Federal Railways' type DDm 915 · Not loaded · Length 10³/₈" (26.4 cm)

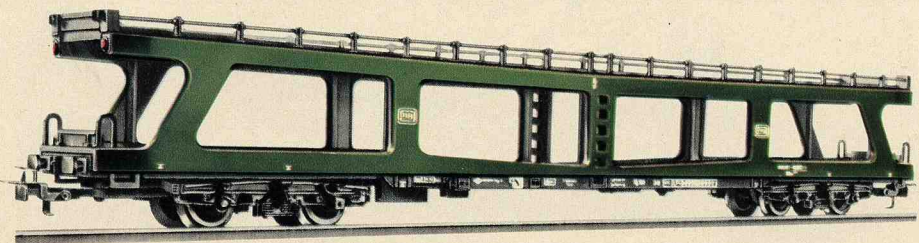

**Cars on railway coaches -
a service the railroads now provide**

4026

Express baggage car · A model of the German Federal Railways' type D ym · Windows inset in plastic frames · Length 9½" (24 cm) · Arranged to take interior lighting set 7077 and current pick-up shoe 7198 (see page 75)

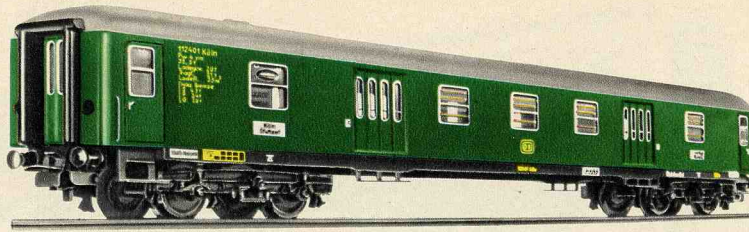

German Federal Railways' express coaches

The bodies of our express coaches are made either of metal or plastic, with inset plastic window frames and panes. Door recesses and other important details, together with the fine, indelible lettering are copied faithfully to scale from the originals. The mat finish makes them look completely realistic. Everything is prepared for the installation of interior lighting. The simulated bogies of Minden-Deutz design have moveable side frames which even out any irregularities in the track so that the cars run safely and very quietly. Simulated rubber beading or bellows are fitted where the coaches are connected together. Automatic coupling with advance uncoupler (RELEX).

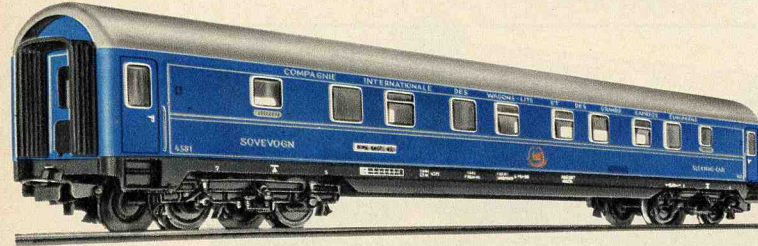

4029

Express sleeping car · A model of the International Sleeping Car Co.'s type ISG No. 4581 · Windows inset in plastic frames · Length 9½" (24 cm) · Arranged to take interior lighting set 7077 and current pick-up shoe 7198 (see page 75)

4037

Express coach · 2nd class, one of the older designs · A model of a type used by the German Federal Railways · Windows with plastic panes · Length 8¾" (22 cm) · Arranged to take interior lighting set 7077 and current pick-up shoe 7198 (see page 75)

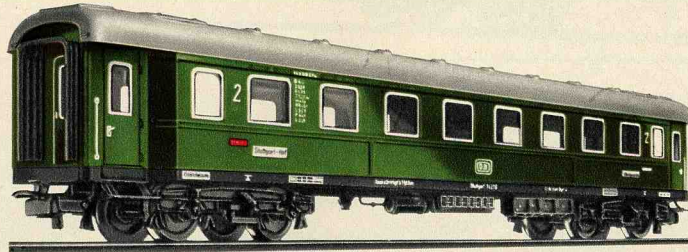

4064

Express sleeping car · 1st and 2nd class · A model of the German Sleeping and Diner Car Co.'s (DSG) WL AB um, series 33 200 · Windows inset in plastic frames · Length 9½" (24 cm) · Arranged to take interior lighting set 7320 (see page 75)

4078

Express coach · 1st class with diner compartment · A model of the German Federal Railways' type AR um 65 · 1st class section finished in blue on the outside, the diner section in red · Windows inset in plastic frames · Length 9½" (24 cm) · Arranged to take interior lighting set 7320 (see page 75)



Interior fittings for coaches 4037, 4045 and 4066

Interior fittings and figures are made of finely detailed plastic, the figures being hand-painted. Illustrated installation instructions are included with every set.

0225

Set of interior fittings for the express coaches with 18 single-colour double seats, 6 single seats, and 2 toilet compartments

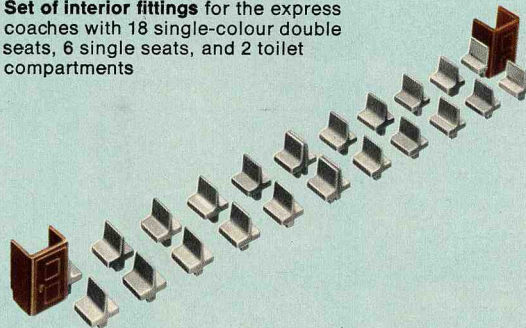

0226

Set of 10 brightly-painted passenger figures to supplement the interior fittings



You can even see the passengers in the express train

4051

Express coach · 1st class · A model of the German Federal Railways' type A üm · **Interior fittings** · Windows inset in plastic frames · Length 9½" (24 cm) · Arranged to take interior lighting set 7077 and current pick-up shoe 7198 (see page 75)



Express coach · Similar to 4051, but with taillights and current pick-up shoe

☛ = 7175 ⚡ = 60015

4053

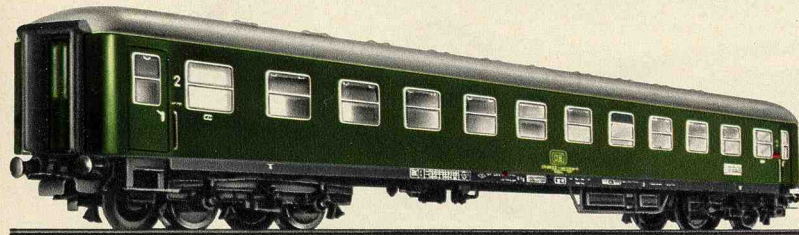
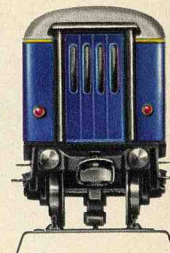

4052

Express coach · 2nd class · A model of the German Federal Railways' type B üm · **Interior fittings** · Windows inset in plastic frames · Length 9½" (24 cm) · Arranged to take interior lighting set 7077 and current pick-up shoe 7198 (see page 75)

4054

Express dining car · A model of the German Federal Railways' type WR üm 132 · **Interior fittings**, divided into kitchen and dining sections · Windows inset in plastic frames · Length 9½" (24 cm) · Arranged to take interior lighting set 7320 (see page 75)

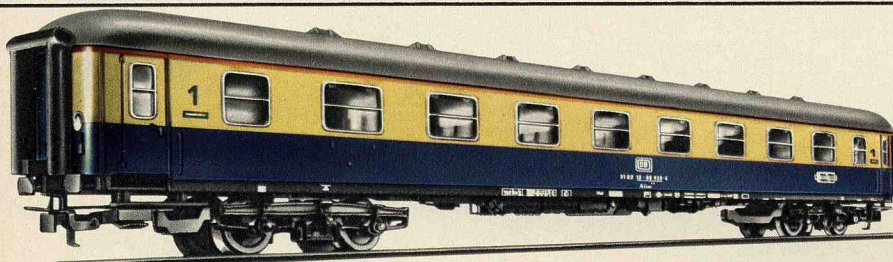

4091

Express coach · 1st class · A model of the German Federal Railways' type A üm 201 · Plastic coach body · **Interior fittings** · Windows inset in plastic frames · Length 10⅝" (27 cm) · Arranged to take interior lighting set 7324 or 7325 (see page 75)

4092

Express coach · 2nd class · A model of the German Federal Railways' type B üm 234 · Plastic coach body · **Interior fittings** · Windows inset in plastic frames · Length 10⅝" (27 cm) · Arranged to take interior lighting set 7324 or 7325 (see page 75)

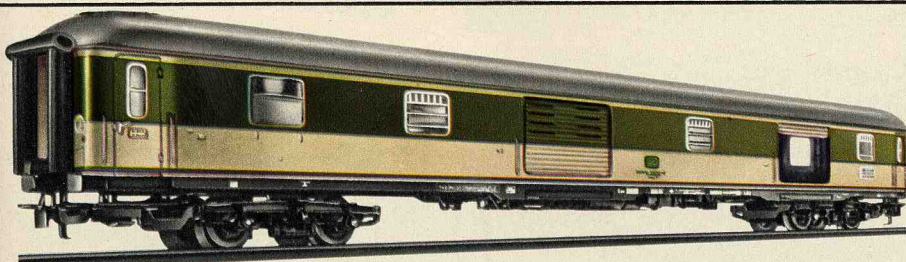

4093

Express baggage car · A model of the German Federal Railways' type D üm 902 · Plastic car body · **Movable roller shutters** on each side · Windows inset in plastic frames · Length 10⅝" (27 cm) · Arranged to take interior lighting set 7324 or 7325 (see page 75)

4094

Express dining car · A model of the German Federal Railways' type WR ümh 132 · Plastic car body · **Interior fittings**, divided into kitchen and dining sections · Windows inset in plastic frames · Length 10⅝" (27 cm) · Arranged to take interior lighting set 7324 or 7325 (see page 75)



It was George Mortimer Pullman who made sleeping cars and dining cars part of an express train: in the year 1850.

4066

Passenger coach · A model of the Swiss Federal Railways' 1st class coach of Series A 2500 · Windows inset in plastic frames · Roof with longitudinal ribs and simulated ventilators · Length 9½" (24 cm) · Arranged to take interior lighting set 7320 (see page 75)



Lightweight express coaches of the Swiss Federal Railways

4068

Express dining car · A model of the Swiss Federal Railways' type RIC diner car · Windows inset in plastic frames · Screwed-on roof with longitudinal ribs · Single-bar pantographs on roof · Length 9½" (24 cm) · Arranged to take interior lighting set 7077 (see page 75)



4063

Express coach · 1st class · A model of the Italian State Railways' type FS Az · **Interior fittings** · Windows inset in plastic frames · Length 9½" (24 cm) · Arranged to take interior lighting set 7077 and current pick-up shoe 7198 (see page 75)

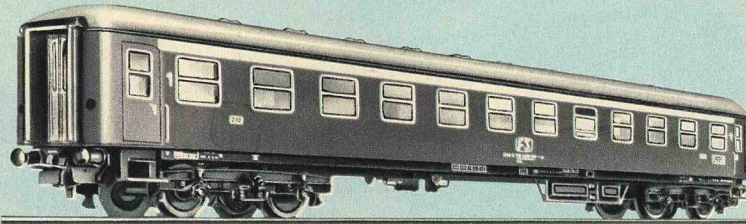

Express coach of the Italian State Railways



Each country has its own distinctive express coaches.

4076

Express coach · 1st class · A model of the French State Railways' (SNCF) stainless steel type A8myfi · Plastic coach body · Interior fittings · Windows inset in plastic frames · Length 9 1/2" (24 cm) · Arranged to take interior lighting set 7197 (see page 75)

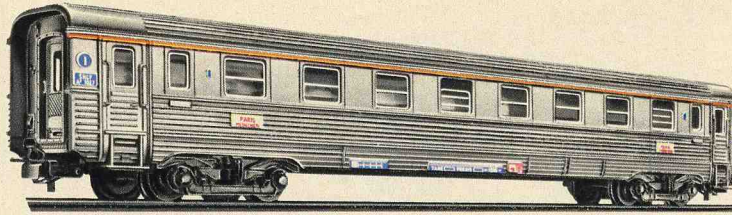

Express coach of the French State Railways

4049

Express passenger coach · 2nd class · A model of the Netherlands Railways' type B 6600 · Windows inset in plastic frames · Length 9 1/2" (24 cm) · Arranged to take interior lighting set 7320 (see page 75)

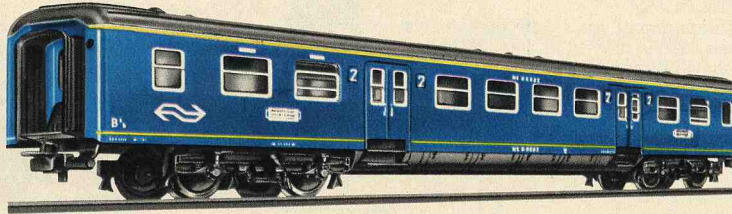

Express coach of the Netherlands Railways

4072

Express coach · 2nd class · A model of the Swedish State Railways' type Bo 1 · Plastic coach body · Windows inset in plastic frames · Length 9 3/8" (23.7 cm) · Arranged to take interior lighting set 7197 (see page 75)

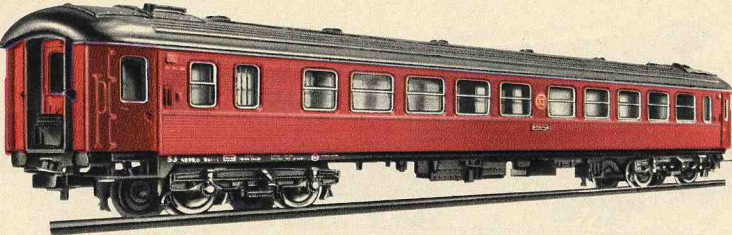

Express coaches of the Swedish State Railways

4073

Express dining car · A model of the Swedish State Railways' type RBo 2 · Plastic car body · Windows inset in plastic frames · Length 9 3/8" (23.7 cm) · Arranged to take interior lighting set 7197 (see page 75)

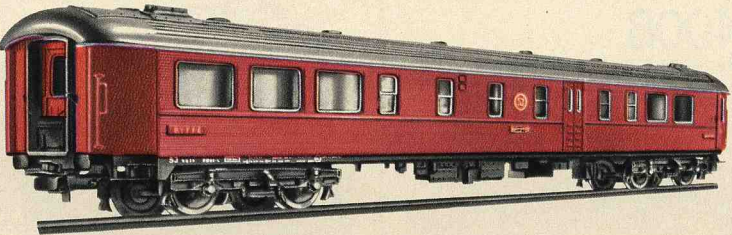

The passenger and express coaches on pages 50/51 are equipped with automatic coupling and advance uncoupler (RELEX).

4045

Express coach · 2nd class · A model of the Danish State Railways' (DSB) type B 2300 · Windows inset in plastic frames · Length 9 1/2" (24 cm) · Arranged to take interior lighting set 7077 and current pick-up shoe 7198 (see page 75)

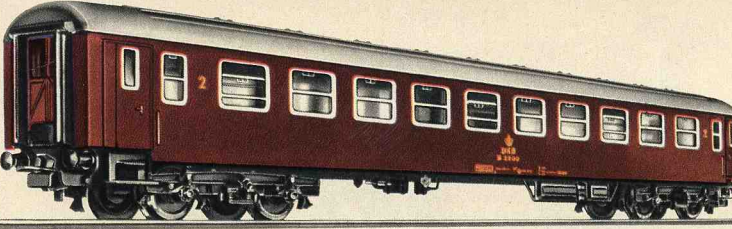

Express coach of the Danish State Railways

Latest type scale models of English locomotives. Handmade and handpainted. Electric motor, with permanent magnet, reversing and self starting. Unexcelled traction power, most economical function. Accurate reproductions of English trains.

CE 3120 Locomotive, with electric headlight. Length with tender . . . 16 inches | Price . . . sh. 30/4 each | Connecting rail with reversing switch . . . Price sh. 2/8 extra

CE 3121 Locomotive, with 2 electric headlights. Length with tender . . . 22 1/2 inches | Price . . . sh. 51/6 each | Connecting rail with reversing switch . . . Price sh. 3/- extra

DR 3190/97 Electric District Railway, 2 cars, reversing from the track; each car fitted with 1 electric lamp. Motor car trail car oval set of 10 rails including connecting rail 5 yards conducting wire without batteries. Length of train 30 inches | Price . . . sh. 47/- each

DR 3190 Electric Motor car, only.

R 3130/71/2MR Electric Locomotive with tender connecting rail with reversing switch. Length of train . . .

R 3130/71/3MR Electric Locomotive with tender connecting rail with reversing switch. Length of train . . .

Gauge 0 = 1 1/4 inches. Gauge 1 = 1 3/4 inches. Gauge 0 = 1 1/4 inches.

Every Märklin model exhibits the features of the original on which it is modelled

4000

Passenger coach · Platform and entrance at each end · Unglazed windows · Length 4½" (11.5 cm)

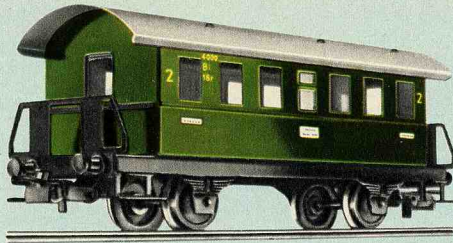

Passenger coaches with automatic coupling and advance uncoupler (RELEX, see page 54)

4004

Compartment coach without brakeman's cab · Sides divided up into 6 compartments · Windows glazed with "cellon" panes · Length 5⅞" (13 cm) · Arranged to take interior lighting set 7074 (see page 75)

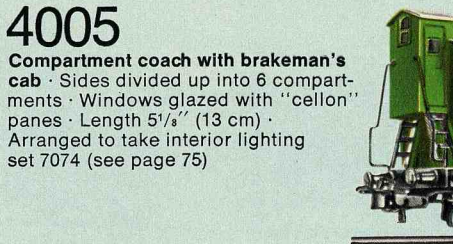

4005

Compartment coach with brakeman's cab · Sides divided up into 6 compartments · Windows glazed with "cellon" panes · Length 5⅞" (13 cm) · Arranged to take interior lighting set 7074 (see page 75)



4007

Passenger coach · A model of a private railroad coach · Platform and entrance at each end · Plastic coach body · Simulated ventilators · Windows inset in plastic frames · **Interior fittings** · Length 4¼" (11 cm) · Arranged to take interior lighting set 7323 (see page 75)

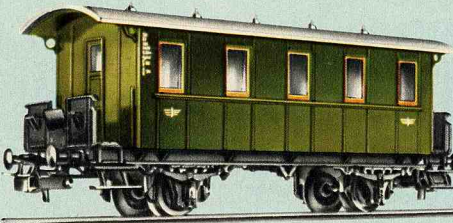

4008

Baggage car · Based on the original Stuttgart Railways' car no. Pwi 0116911 · Platform and entrance at each end · Plastic car body · Simulated ventilators and superstructure for conductor's cab · Windows inset in plastic frames · Length 4¼" (11 cm) · Arranged to take interior lighting set 7323 (see page 75)

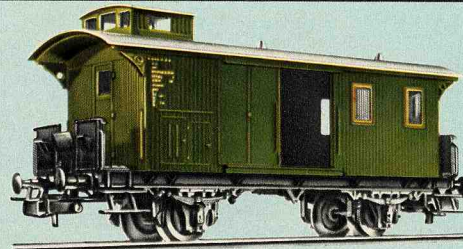

4040

Passenger coach · Platform and entrance at each end · Unglazed windows · Length 4½" (11.5 cm)

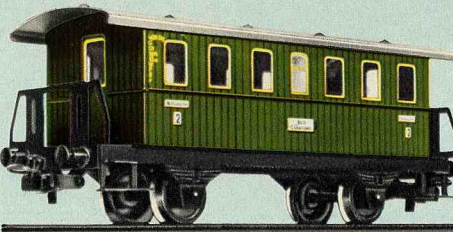

4079

Passenger coach · A model of the German Federal Railways' type B3yge · Plastic coach body · Windows inset in plastic frames · Simulated rubber beading · Length 6" (15.2 cm) · Arranged to take interior lighting set 7074 (see page 75)

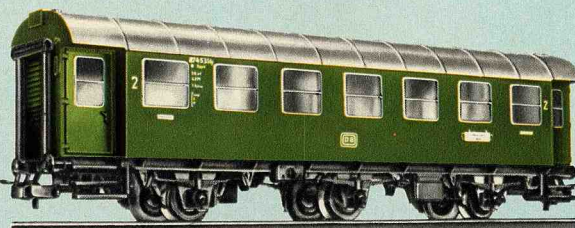

4080

Passenger coach with baggage compartment · A model of the German Federal Railways' type BD3yge · Plastic coach body · Windows inset in plastic frames · Simulated rubber beading · Length 6" (15.2 cm) · Arranged to take interior lighting set 7074 (see page 75)



Compartment coaches, brake cab, open platform - as it was not so long ago

Freight cars with plastic bodies and automatic coupling and advance uncoupler (RELEX, see page 54)



4504
Low-sided car · Loaded with miniature automobile · Length 4" (10 cm)

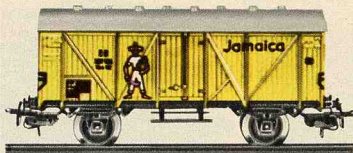

4509
Banana car · Length 4" (10 cm)



4511
Pulverised coal car · Length 4" (10 cm)



4500
Tank car · ARAL · Length 4" (10 cm)

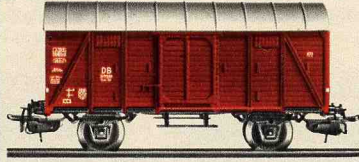

4505
Box car · Length 4" (10 cm)

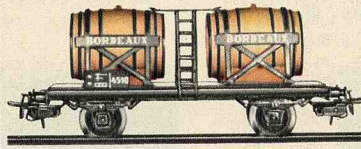

4510
Wine car · Length 4" (10 cm)

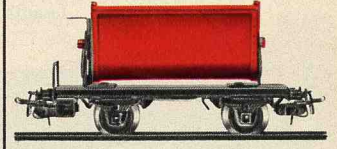

4513
Dump car · Will dump to either side · With locking lever · Length 3 3/4" (8.5 cm)



4501
Tank car · ESSO · Length 4" (10 cm)

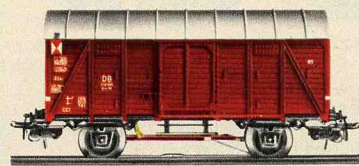

4506
Box car · Working taillights placed at side · Current pick-up shoe · Length 4" (10 cm)

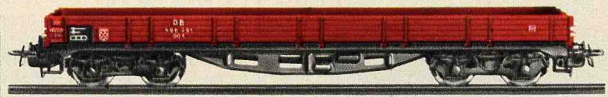

4514
Low-sided car · Length 7" (18 cm)



4502
Tank car · SHELL · Length 4" (10 cm)

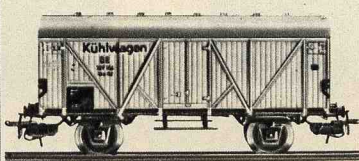

4508
Refrigerator car · Length 4" (10 cm)



4517
Covered flat car · Length 7" (18 cm)

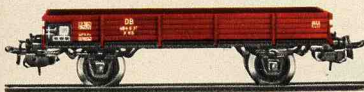

4503
Low-sided car · Length 4" (10 cm)

⊙ = 60010

All the underframes of these cars are made of metal and painted mat black. All wheels are of die-cast zinc. All lengths quoted are measured over the buffers.



A freight train cannot be too long.



4600
Freight train luggage car (German Federal Railways' type Dg) · Doors on both sides which will open · Length 3½" (9 cm)

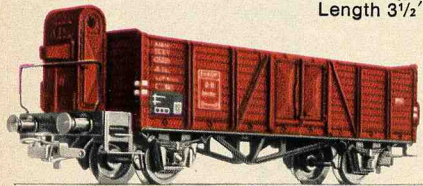

4601
Open freight car with brakeman's cab (German Federal Railways' type Omm 33) · Length 4½" (11.5 cm)



4602
Open freight car (German Federal Railways' type Omm 52) · Length 4½" (11.5 cm)



4604
Open freight car (German Federal Railways' type Omm 52) · With removable load simulating coal · Length 4½" (11.5 cm)

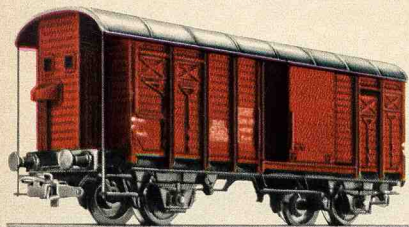

4605
Box car with brakeman's cab, of the Swiss Federal Railways (SBB-K³) · Doors on both sides which will open · Length 4¼" (11 cm)

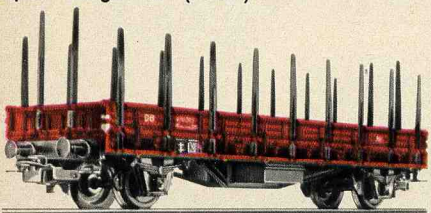

4607
Low-sided car (German Federal Railways' type Rmms 33) · With removable stakes which can be stored in the sliding box under the floor of the car · Length 5½" (13 cm)

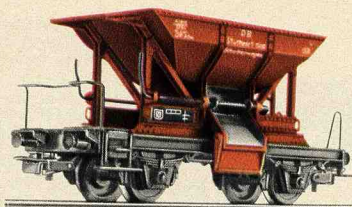

4610
Ballast car with unloading doors operated by a hand lever · Length 3¾" (9.5 cm)

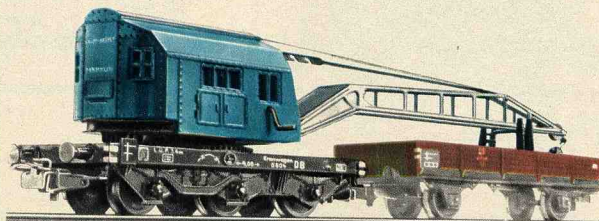

4611
Crane car with slewing crane, with movable boom and boom support · Crane hook can be raised and lowered by handle · Underframe 3½" (9 cm) long · (Low-sided car 4503 is not included in the price but is recommended for moving the crane car.)



4612
Automobile transporter with loading ramp · Not loaded · Length 4½" (11.5 cm) · (On the German Federal Railways two transporters are always coupled together to form a unit known as Off 52)



4613
Automobile transporter with loading ramp · Loaded with miniature automobiles · Length 4½" (11.5 cm)

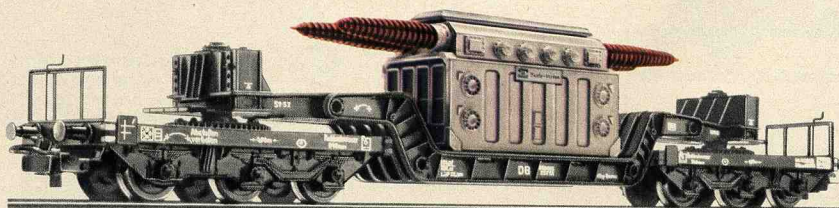

4617
Well car · Loaded with transformer · Length 9⅞" (25 cm)

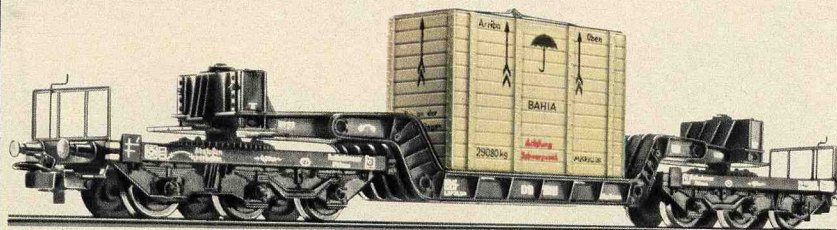

4618
Well car · Loaded with crate · Length 9⅞" (25 cm)

Scale model freight cars with automatic coupling and advance uncoupler (RELEX)

We have specially worked out the details of these models. The RELEX coupling is quite essential for realistic switching. When the coupling has been opened by means of an uncoupling track section, the catch of the coupling remains open so that the car can be pushed away or allowed to roll down a ramp.

Märklin model freight cars do not merely run on the rails – you can actually set them to work



4619

Sliding-roof car (German Federal Railways' type Kmmks 51) · The two halves of the roof will slide open · Length 4½" (11.5 cm)



4624

High-capacity freight car (semitrailer) · A model of the German Federal Railways' type OOtz 50 · Length 5¼" (13.3 cm)

This type of car is used in international traffic for transporting coal, coke, ore, etc. generally in permanently made-up high-capacity trains.



4626

High-capacity freight car with hinged roof covers · A model of the German Federal Railways' type KKt 57 · All the covers will open · Length 5¼" (13.3 cm)

On a number of high-capacity freight cars, fixed covers are fitted so that bulk materials which need protection from the elements, e.g. grain, can also be carried.

Märklin – HAMO Sets of wheels

for two-rail D.C. operation

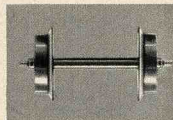

7587

Wheel set, consisting of 3 sets of axles · For converting cars 4611, 4617 and 4618 to two-rail D.C. operation

7588

Wheel set, consisting of 4 sets of axles · For converting all cars of the 4600 series (except 4611, 4617, 4618, 4631, 4633, 4635, 4644, 4646, 4647, 4657, 4664, 4668 and all freight cars with 4 axles) to two-rail D.C. operation

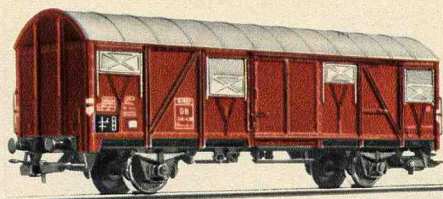

4627

Box car · A model of the German Federal Railways' type Glimmehs 57 · Length 5¼" (13.3 cm)

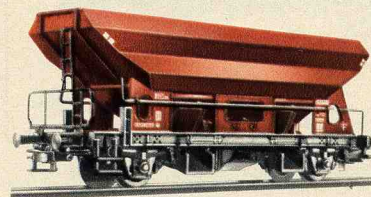

4631

Side dumping car · A model of the German Federal Railways' type Otmm 70 · Length 4¾" (11.2 cm)

The discharging doors can be opened by hand levers, or by remote control using the uncoupling track section 5112 (page 62) and 2197 (page 64).

Uses for 4631 are shown on page 57.



4632

Beer car · Length 7¾" (19.5 cm)

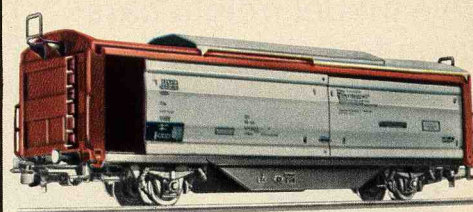

4633

Freight car with sliding sides and sliding roof (German Federal Railways' type Klmmgks 66) · The halves of the roof and the doors will slide open · Length 6¼" (15.7 cm)

4634

Beer car · A model of a car belonging to the Dortmunder Union Brewery · Roof with simulated ventilators · Length 5¼" (13.3 cm)



4635

Tipping bucket car · A model of the German Federal Railways' type Omml 51 · Buckets can be tipped after the center holding bar is unfastened · Length 4¼" (10.5 cm)

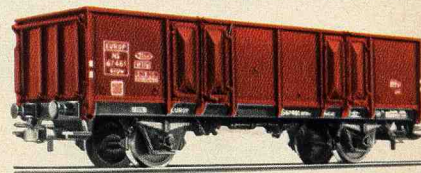

4639

Open freight car · A model of a Netherlands State Railways' (NS) car · Length 4½" (11.5 cm)



Real marshalling, remote-controlled unloading gates, sliding sides, removable stakes.

Scale model freight cars with automatic coupling and advance uncoupler (RELEX, see page 54)



4644
Tank car · A model of the standard tank car with BP markings · Length 4" (10 cm)



4646
Tank car · A model of the standard tank car with ARAL markings · Length 4" (10 cm)



4647 **new**
Tank car · A model of the standard tank car with BAYER markings · Length 4" (10 cm)

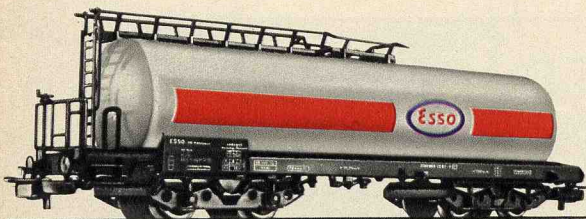

4650
Tank car · ESSO · Length 6 1/2" (16.4 cm)



4658
Tank car for fine bulk material · A model of the German Federal Railways' type Kds 54, in use as a private car of the Franken Sugar Co. · Length 4" (10 cm)



4660
Beer car · A model of a car owned by the Kulmbacher Mönchshof-Bräu · Roof with simulated ventilators · Length 5 1/4" (13.3 cm)



4667
Beer car · A model of a car owned by the Bavaria St. Pauli Brewery · Roof with simulated ventilators · Length 5 1/4" (13.3 cm)

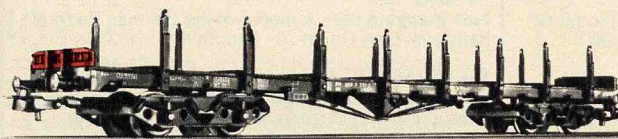

4663
Flat car · A model of the German Federal Railways' type SSImas 53 · Die-cast zinc body · Side stanchions fold down · Length 9" (22.7 cm)



4664
Container car · A model of the German Federal Railways' "Berlin" type container car · Loaded with two removable containers · Length 6 1/8" (15.6 cm)



4668
Container car · A model of the German Federal Railways' "Berlin" type container car · Loaded with two removable containers · Length 6 1/8" (15.6 cm)

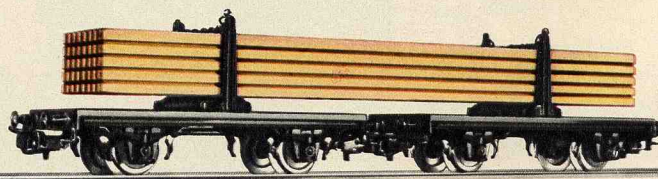

4665
Logging car in two parts · Loaded with square timbers · Length 7 5/8" (19.5 cm)



4666
Beer car · Model of a car owned by the Würzburger Hof Brewery · Roof with simulated ventilators · Length 5 1/4" (13.3 cm)

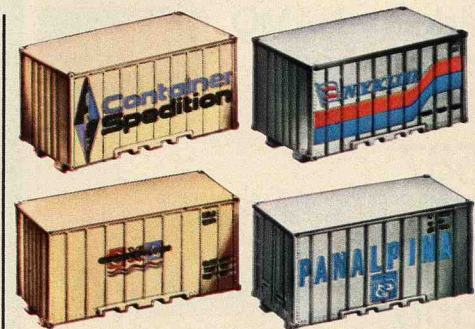

7291
Pack of 4 containers, with different inscriptions · Will fit on the underframes of cars 4664 and 4668

Containers dominate long-distance freight traffic



4669 **new**

Beer car · A model of a car belonging to the Kulmbacher Reichelbräu · Roof with simulated ventilators · Length 5 1/4" (13.3 cm)

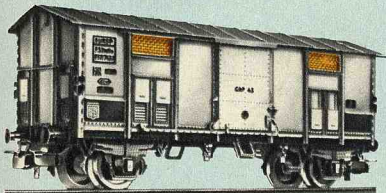

4550

Box car · A model of an Italian State Railways' car (FS) · Length 4 1/4" (11 cm)

Märklin – HAMO Wheel sets

for two-rail D.C. operation

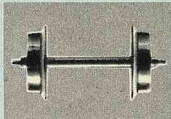

7587

Wheel set, consisting of 3 sets of axles · For converting cars 4611, 4617 and 4618 to two-rail D.C. operation

7588

Wheel set, consisting of 4 sets of axles · For converting all cars of the 4600 series (except 4611, 4617, 4618, 4631, 4633, 4635, 4644, 4646, 4647, 4657, 4664, 4668 and all freight cars with 4 axles) to two-rail D.C. operation

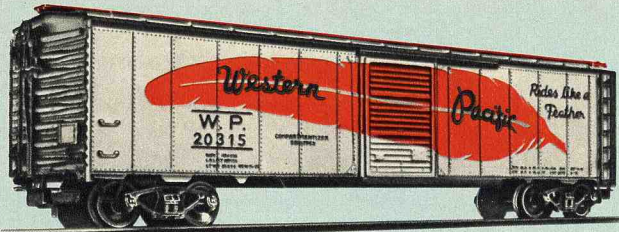

4571

Box car · A model of the 50 ton-car of Western Pacific Railroad · Roof walk mounted on roof · Doors which will open on both sides · Length 8" (20.5 cm)

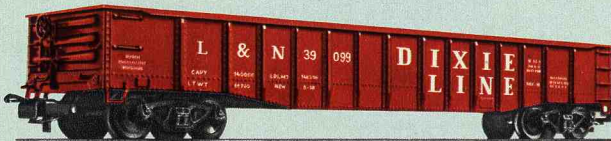

4575

Gondola · A "Dixie" line model · Length 7 1/8" (20 cm)



4576

Caboose · Roof superstructure with walkway and ladders · Length 3 1/8" (8 cm)



4577

Caboose · Roof superstructure with walkway and ladders · Length 3 1/8" (8 cm)

Scale model freight car 4631 (see page 55)

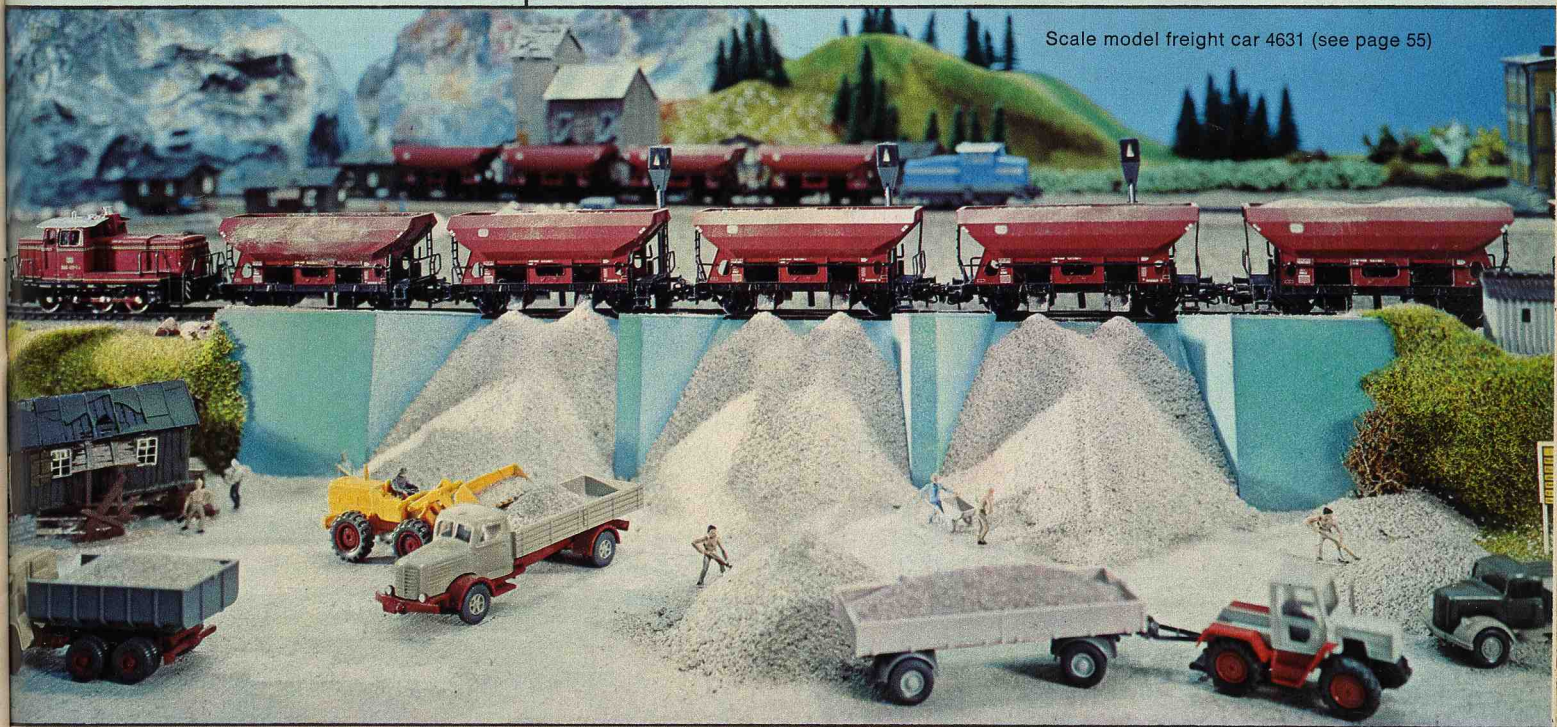

Car kits

These car kits enable you to build your own cars. Each kit includes the necessary illustrated instructions and all kits include automatic couplings with advance uncoupler (RELEX). To assemble them, the only tools needed are a screwdriver and a pair of pliers, with a hammer in addition for car 4902.

The models 4802, 4918, 4934 and 4937 are available only in kit form.



4918
Refrigerator car kit
Assembled kit 4918

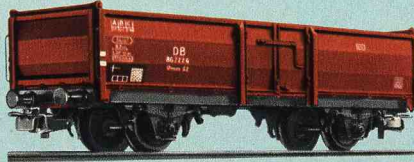

4902
Open freight car kit
Assembled kit 4902



4937
Box car kit
Assembled kit 4937



4802
Passenger coach kit
Assembled kit 4802

4934
Beer car kit
Assembled kit 4934



Märklin Old-timer: 0 gauge constructed in the years 1926—1938

You can rightly be particularly proud of model freight cars which you build yourself

Märklin M-tracks (M= Metal rail ties) for trouble-free layout

Here we show our proven metal track. The special feature of this track is the covered current conductor in the road with stud contacts at the center of the track. The long current pick-ups between the wheels of the locomotives slide over these contacts. Each track section consists of the roadbed, which looks very realistic with its rock ballast and strong ties, and the two rails which are electrically connected to the

roadbed. At the opposite ends of each rail is a joiner. The current-carrying rail has spring contact tongues at both ends. These lock together when the track sections are joined, the joiners mentioned sliding over the outer rails at the same time. The result is the reliable electrical contact which is the feature of the Märklin system and at the same time the track sections are mechanically held firmly together.

The screws needed for mounting the track when sound-deadening strips 7171 (see page 62) are used, are included. When sound-deadening strips are not used, the screws 7299 (see page 62) are recommended.

How the different Märklin M-track circles compare

The drawing shows the three Märklin M-track circles, with their radii, intervals and angles, and also the number of track sections required for a half circle.

- 1 circle 5200 = 12 track sections
- 1 circle 5100 = 12 track sections
- 1 circle 5120 = 8 track sections

1

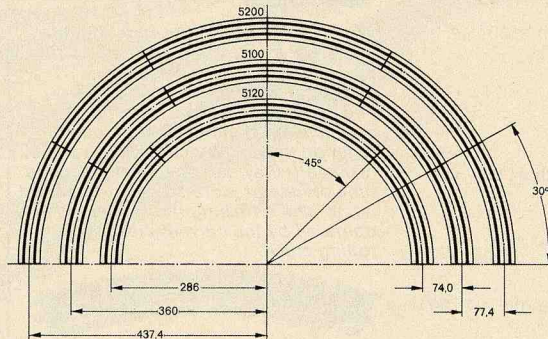

Track sections of the 5100 and 5200 series enables concentric circles to be laid with a track center spacing (measured from contact stud to contact stud) of 3" (77.4 mm) and an operating clearance between the tracks of 1 1/2" (39 mm). The 5202, 5221 or 5140 turn-outs are used to cross from the inner to the outer loop.

2

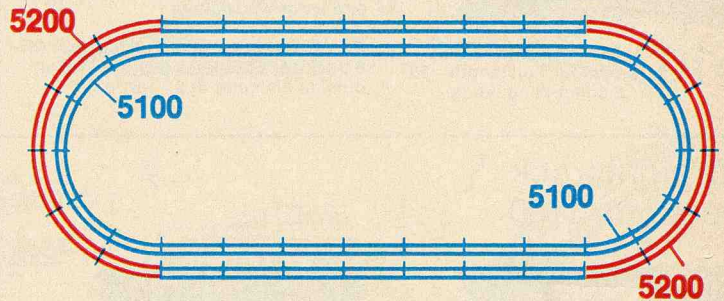

3

One section of track can be insulated from another by means of the insulator piece 5022 (see page 63) or a piece of ordinary cardboard. No special insulating track section is needed, so space is saved.

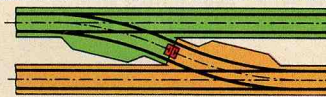

4

A special feature of the Märklin track is the excellent current feeding qualities. When one of the rail joiners is bent, which can always happen on a model railway, this has no effect because the second joiner will still join the track sections and make electrical contact perfectly satisfactorily. No soldered joints are needed.

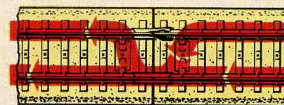

5

On track layouts with sidings or branches off the main line, locomotives and trains can run in the same direction or in opposite directions. No special reversing arrangement is necessary, nor do terminals on the transformer have to be switched over. This is one of the advantages of the Märklin system.

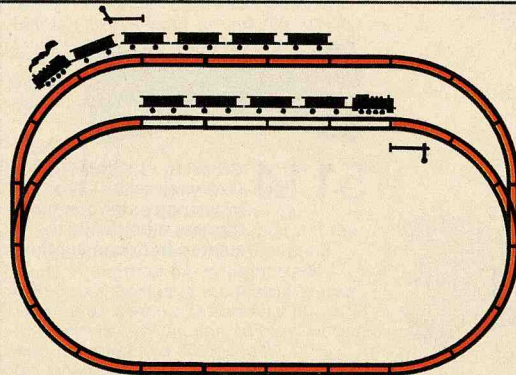

The robust Märklin M-tracks have proved themselves a million times over

Curved track sections 5100 for standard circle

Twelve 5100 track sections form a circle with an outside diameter of 30" (76 cm).



5100 Full length = 30°



5101 Half length = 15°



5102 Quarter length = 7° 30'

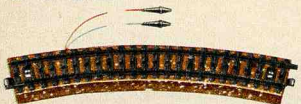

5103 Feeder track section, curved · Full length = 30° · 2 connecting leads



5147 Switching track section, curved · Half length = 15°

Switching track sections

The switching track sections (5146, 5147 and 5213) can trigger off one function in each direction of travel, i.e. two in all; they can do this at the same time on one or more solenoid-operated items. The switching track sections are operated by the current pickups on the rolling stock.



5120 Track with small radius for branch lines and industrial sidings

Curved track section · Full length = 45° · 8 track sections form a circle with an outside diameter of 24" (61 cm)

Curved track sections 5200 for large parallel curve

Twelve 5200 track sections form a circle with an outside diameter of 36" (91.2 cm).

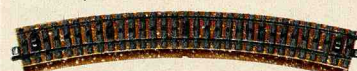

5200 Full length = 30°

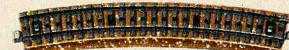

5206 Length = 24° 17' · Matches the curve of the turnouts 5202 and 5221



5201 Half length = 15°



5205 Length = 5° 43' · This section, used with 5206, equals section 5200



5213 Switching track section, curved · For parallel curve · Half length = 15° · Construction and operation as for 5146/5147



5208 Make-up section, straight · Length 5/16" (8 mm)



5210 Make-up section, straight · Length 5/8" (16 mm)



5211 Crossing · Crossing angle 48 1/2° · Length 3 7/8" (98 mm) · The crossing center conductors are electrically insulated from one another

Straight track sections 5100



5106 Full length = 7" (180 mm)



5107 Half length = 3 1/2" (90 mm)



5129 Make-up section · Length 2 3/4" (70 mm)



5108 Quarter length = 1 3/4" (45 mm)



5109 3/16 length = 1 5/16" (33.5 mm)



5110 1/8 length = 7/8" (22.5 mm)

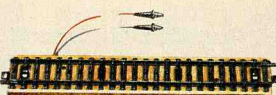

5111 Feeder track section, straight · Full length = 7" (180 mm) · 2 connecting leads



5131 Feeder track section, straight · Full length = 7" (180 mm) · Built-in capacitor to suppress radio interference · 2 connecting leads · For 1 traction current circuit, 1 x 5131 should be used



5146 Switching track section, straight · Half length = 3 1/2" (90 mm)



5114 Crossing · Length 7 5/8" (193 mm) = 30° · The crossing center conductors are electrically insulated from one another

Märklin M-turnouts 5100 and 5200 with sprung points

with double solenoid operation for remote control

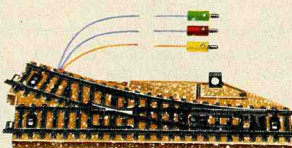

5202 Pair of solenoid turnouts · Consisting of one right-hand and one left-hand turnout, each with double solenoid operation · Working signal lights · The track lengths are as for track sections 5206 and 5106 (see Fig. 1 and 6, page 61)

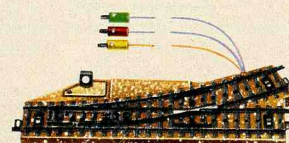

operation · Working signal lights · The track lengths are as for track sections 5206 and 5106 (see Fig. 1 and 6, page 61)

⚡ = 60000



5221 Pair of manually operated turnouts · Track dimensions as for 5202



5140 Pair of solenoid-operated curved turnouts · Consisting of one right-hand and one left-hand inside curve turnout, each operated by double solenoid · Working signal lights · Length and curvature of branch tracks as for track section 5100 · Length of outer curve 10 1/2" (265.4 mm)

⚡ = 60000



If curved turnouts are included in the layout the train can change when already in the curve from one track to the other. The narrow interval between the parallel curves of the track (3" = 77.4 mm) is maintained and space is saved for a longer overtaking section (see Fig. 7, page 61).

There is always the right track section for even the most sophisticated layout.

Märklin M-turnouts and how to use them

When laying out a siding, form the reverse curve by using curved track 5100 with turnout 5117 (Fig. 2); distance between track centers $3\frac{1}{8}'' = 96.4$ mm. With turnout 5137, which includes a short curved section, the reverse curve is also formed by using curved track 5100; distance between track centers $3\frac{1}{8}'' = 96.4$ mm (Fig. 3). Curved track 5101 is used to make the reverse curve when the short curved section in the turnout is the opposite way round. Here, the distance between track centers is $2\frac{1}{8}'' = 54.8$ mm (Fig. 4). With the 5202 and 5221 (Fig. 1) and 5214 (Fig. 5) turnouts on the other hand, use track section 5206 to form the reverse curve. The turnout, which is $\frac{1}{8}''$ shorter in the curve, gives a reduced distance of $3'' = 77.4$ mm between track centers.

The electromagnetic turnouts 5117, 5137, 5140 and 5202 are operated by double solenoids. When crossed in the reverse direction, the points of all the turnouts are opened up by the wheels of the rolling stock. There are no derailments. The turnouts return automatically to their initial setting. The working signal lights show the setting of the turnout. Further turnouts can be joined directly on to either end of the turnout section.

Four electro-magnetic turnouts can be connected to one control panel (see page 73).

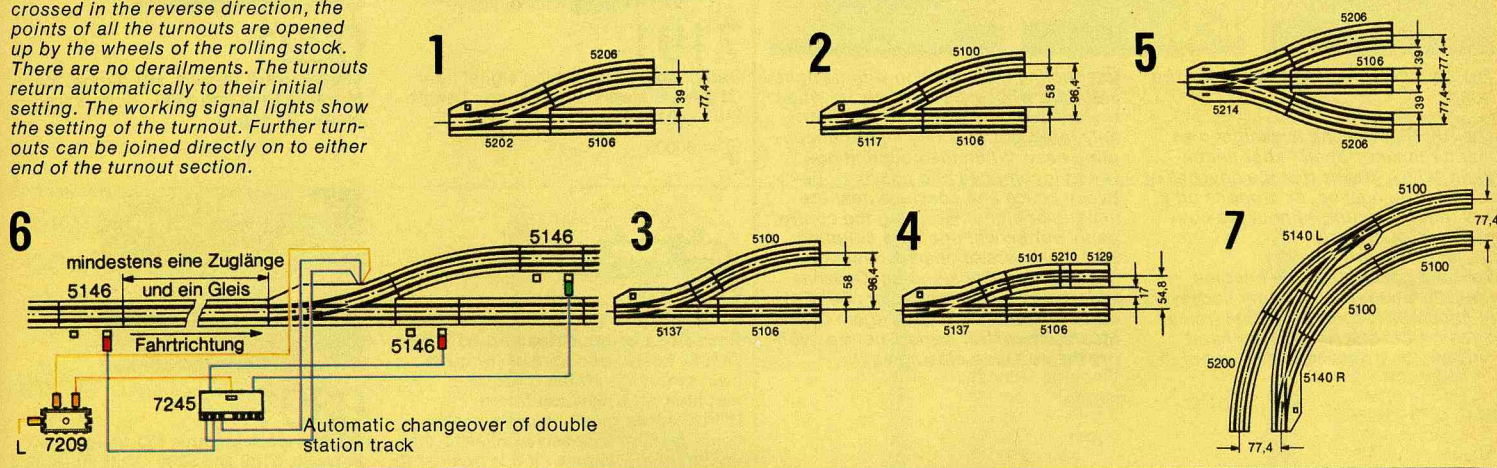
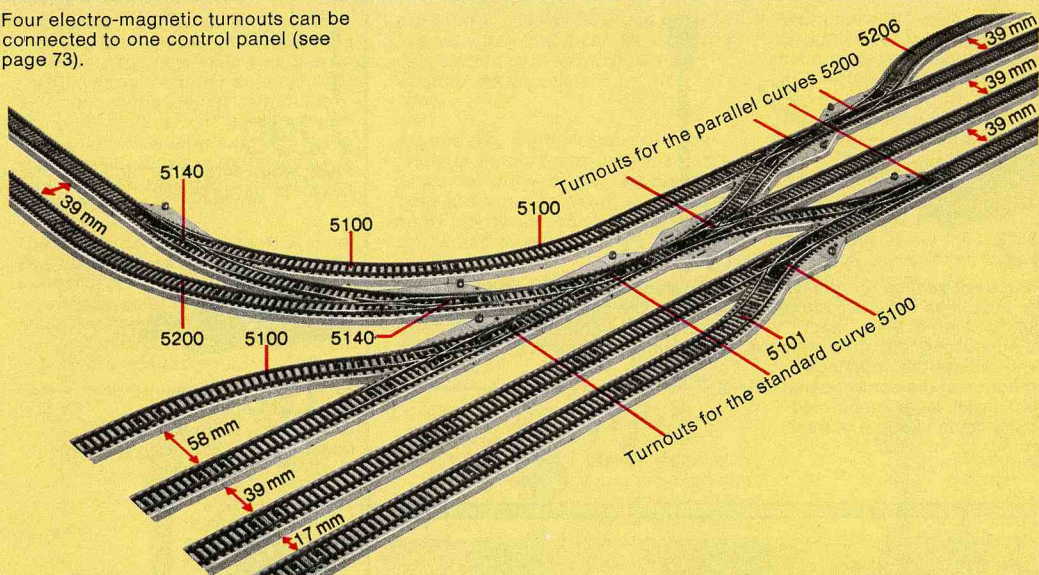

Märklin M-turnouts 5100 and 5200 with sprung points

with double solenoid operation for remote control

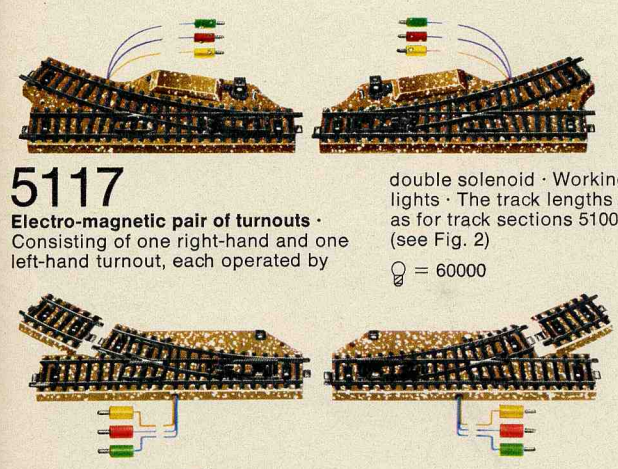

5117
Electro-magnetic pair of turnouts · Consisting of one right-hand and one left-hand turnout, each operated by

double solenoid · Working signal lights · The track lengths are the same as for track sections 5100 and 5106 (see Fig. 2)
⚡ = 60000

5137 new
Electro-magnetic pair of turnouts · Consisting of one right-hand and one left-hand turnout, each operated by double solenoid · Working signal

lights · Length of the straight track $7''$ (180 mm) · Radius of branch line $14''$ (360 mm) · Turnout angle $22^\circ 30'$, can be changed to 30° by using the curved track section 5102 supplied (see Fig. 3 and 4)
⚡ = 60000

5128
Double slip switch · 30° crossing angle · Operated by double solenoid · Working electric signal lights which change to show the setting of the points (crossing or curve) · Manual switching lever to permit setting by hand · Length of straight section $7\frac{1}{2}''$ (193 mm) · The curvature is the same as for track section 5100
⚡ = 60000

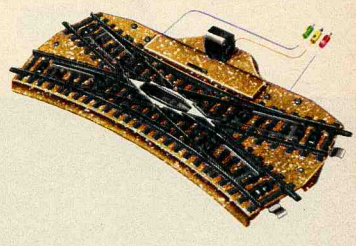

5207
Double slip switch · Enables the track spacing of $3''$ (77.4 mm) to be maintained · Operated by double solenoid · Manual switch lever on the drive case · Length of straight section $7''$ (180 mm) · The curve is the same as for 5202, 5221 and 5206 · Two make-up sections 5208, each $\frac{5}{16}''$ (8 mm) long, are included



5214
Symmetrical three-way turnout operated by 2 double solenoids · 2 hand levers for manual setting of the two pairs of turnouts · 5 connecting leads · Length of the straight track $7''$ (180 mm) · Radius of the branch tracks $17\frac{1}{4}''$ (437.4 mm), the same as for outer track circle · When used in conjunction with track section 5206, the $3''$ (77.4 mm) track center spacing can be maintained on both sides (see Fig. 5)

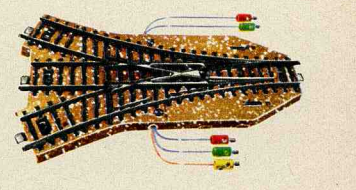

All possible turnout combinations for four different spacings between tracks

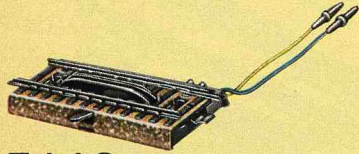

5112

Uncoupling track section for releasing automatic couplings · The two ramps on the right and left of the contact studs are raised magnetically by remote control and release the couplings when the button of the control panel or the manual switch lever is operated · 2 connecting leads · Length of track 3 1/2" (90 mm)



5113

Light standard for the uncoupling track section · Die-cast zinc · The signal on the standard lights up during uncoupling · Height 3 1/3" (85 mm)

Ⓛ = 60010

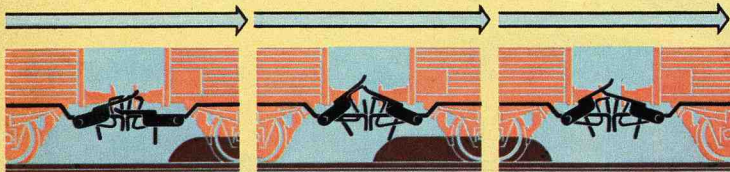

The coupling is opened by raising the ramp.

The RELEX coupling is designed so that it remains "open" after uncoupling, which means that the coaches or cars can be pushed, or dropped off at any required point, without the couplings closing again.

Railroad operations only become realistic when it is no longer necessary to uncouple locomotives from trains, or cars from one another, by hand. This can be achieved by the use of the

uncoupling track section with its light standard whose signal lights up when the uncoupler is operated. That not only looks good, it also makes uncoupling easy. When the coupling between locomotive and coach, or between coach and coach, is near the uncoupler signal, pressing the control panel button will open the coupling and the detached coach or section of the train remains standing. Coaches with the advance uncoupler (RELEX) can then be pushed back again by the locomotive under remote control without the coupling closing again.



7299

Flush wood screws for mounting metal track · In packs of 200



7190

Buffer stop · Of riveted steel construction · 2 3/4" long (70 mm)



7191

Buffer stop with working signal light · Of riveted steel construction · Length 2 3/4" (70 mm)

Ⓛ = 60000



7171

Sound deadening strips packed in 50s with 50 flush wood screws for quiet train operation · If the tracks are mounted on a plywood board, the trains as they move naturally make some, but not excessive, noise to the rhythm of the wheels · If it is desired to dampen this noise down to about half, it is recommended that the tracks, turnouts and crossings should be paid on sound-deadening strips · This makes no difference to the mounting of the catenary system

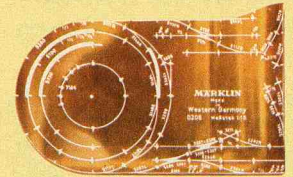

0206

Track planning template for HO gauge Märklin M-track sections (series 5100/5200) · On the template the track sections, turnouts, crossings, etc. are cut out on a scale of 1:10 and they can easily be transferred on to paper with a sharp pencil



0321

Märklin track layouts, HO gauge, for M-tracks 5100 and 5200 · Simple track plans · 24 pages

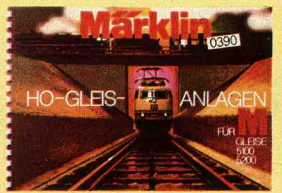

0391

Märklin track layouts, HO gauge, for M-tracks 5100 and 5200 · With full-color pictures and detailed track plans of 16 layout suggestions · 56 pages

A full description of these brochures appears on page 22



The Märklin RELEX coupling is opened by remote control and then remains open to allow marshalling

The Märklin range of signals for M-tracks

There should be a few suitably arranged signals, even on a small railway layout and not just because the play of red, green and amber lights looks attractive. The home and siding signals regulate the traffic by setting them at red and green by remote control, the starting and stopping of the trains can be controlled at the same time.

And that is not all: switching track sections have only to be included and connected to the signals and then one train controls the other automatically by means of the signals, without it being possible for an "accident" to happen (block operation). In this way, while some trains are travelling as programmed, you are free to see to other things, e.g. switching.

The installation of the signals is simple. Their base plates are clamped under curved or straight metal track sections, on either side of the track, and the leads are connected as shown in the instructions accompanying them. The signals are connected electrically to

the control panels (7072, see page 73) in such a way that it can be seen from the position of the switch buttons whether the signals are at "stop" or "go".

Anyone who wants his layout to be realistic should install distant signals as well as the home signals described. They are mounted in the same way as home signals, to which they are simply connected by a lead.

With a control panel 7072, it is possible to operate, for example, 4 home signals 7039 with distant signals and also groups of signals and turnouts.

The home and siding signals have rail current switches, by means of which the current in the contact studs and in the overhead line can be altered.

The silver contacts in the switches enable them to cope with heavy loads.

The connecting wires have color-coded plugs, with side sockets, allowing other plugs to be inserted, in addition, sockets are incorporated into the signal bases for connection to the overhead line and ground. Lighting is provided by small bulbs. Insulators for the current conductor, a base plate and precise installation instructions are included in each pack.

Distant signals without train control

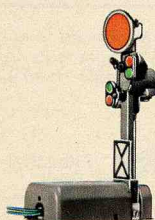

7036
Distant signal with movable disc. Signal lights change from amber/amber to green/green. Double solenoid. Used with home signal 7039. Width 1 1/8" (28 mm). Length 2 1/2" (65 mm). Height 2 7/8" (73 mm).
⊙ = 60000

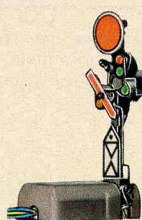

7038
Distant signal with extra movable arm and movable disc. Signal lights change either as 7036 or from amber/amber to amber/amber/green. 2 double solenoids. Used mostly with home signal 7040 or 7041. Width 1 1/8" (28 mm). Length 2 1/2" (65 mm). Height 2 7/8" (73 mm).
⊙ = 60000

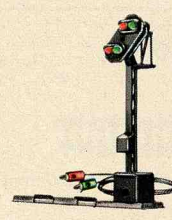

7187
Color light distant signal. Used only in conjunction with home light signal 7188. Signal lights change from green/green to amber/amber using 4 bulbs. Width 5/8" (16 mm). Length 7/16" (11 mm). Height 2 3/8" (60 mm).
⊙ = 60202 green
60204 orange

Signals with train control for catenary and rail conductors

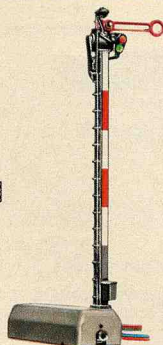
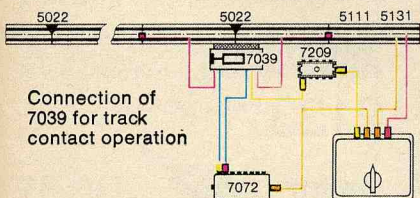

7039
Home signal with one semaphore arm. Signal light changes from red to green. Double solenoid. Width 1" (27 mm). Length 2 3/4" (70 mm). Height 5" (125 mm).
⊙ = 60000

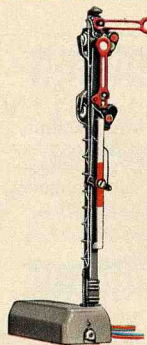

7040
Home signal with two coupled semaphore arms. Signal lights change from red to green/amber. Double solenoid. Width 1" (27 mm). Length 2 3/4" (70 mm). Height 5" (125 mm).
⊙ = 60000

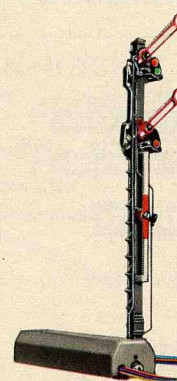

7041
Home signal with two independent semaphore arms. Signal lights change from red to green or red to green/amber. 3 solenoids. Width 1" (27 mm). Length 3 3/4" (97 mm). Height 5" (125 mm).
⊙ = 60000

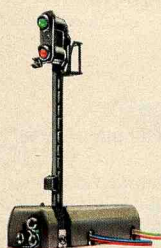

7188
Color light home signal. Signal light changes from red to green. Double solenoid. Lighting by two bulbs. Additional manual switching lever. Pair of sockets for connection to distant signal 7187. Width 1 1/8" (28 mm). Length 2 3/4" (70 mm). Height 3 1/2" (90 mm).
⊙ = 60001 red
60002 green

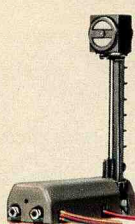

7042
Yard and siding signal. Mast with movable front and rear discs. Double solenoid. Width 1 1/8" (28 mm). Length 2 3/4" (70 mm). Height 2 3/4" (70 mm).
⊙ = 60000

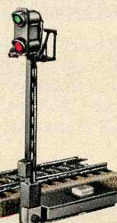

7339
Color light home signal. Signal light changes from red to green by manual operation, which at the same time controls the current to the section of metal track connected to the signal. Additional track section 3 1/2" (90 mm) long with interrupted central conductor. Width 2 1/8" (55 mm). Length 3 1/2" (90 mm). Height 3 1/2" (90 mm).
⊙ = 60001 red
60002 green

7045
Universal remote control switch. It can be given various functions which it then carries out automatically and reliably, for example, causing a moving train to switch station lighting on and off, overriding the control by signal for trains travelling in the opposite direction, and many more. It is all fully described in the installation instructions and our Signal Manual. The universal remote control switch is operated from the control panel, or by switching track sections. Double solenoid. Width 1 1/8" (28 mm). Length 2 3/4" (70 mm). Height 9/16" (22 mm).

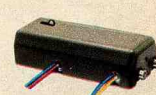

5015
Insulation marker for marking insulation points

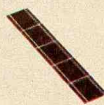

5022
Center track conductor insulation for insulating 5 points

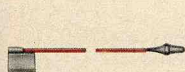

5004
Connecting lead for center track conductor. Length 29 1/2" (750 mm)

0341
Märklin Signal Manual for M-tracks. For description see page 22



Signals control the operation of trains – in block operation the trains even control one another

Märklin K-tracks 2100 (K = plastic ties)

The Märklin K-track, series 2100, uses the same stud contact system, the advantages of which were described on page 59. With these track sections the two rails are laid on plastic strip with ties. The contact studs project through from underneath the ties and ensure very reliable current pickup. The six-fold connection between one track section and the next consists of rail joiners, sprung connectors for the

center conductor and snap couplings for the plastic tie strips. Flush wood screws 7599 (see page 65) are recommended for fastening the K-tracks to a base.

The five Märklin K-track circles:

- 1 industrial circle 2110 = 8 track sections
- 1 standard circle I 2121 = 12 track sections
- 1 standard circle II 2131 = 12 track sections
- 1 large circle I 2141 = 12 track sections
- 1 large circle II 2151 = 12 track sections

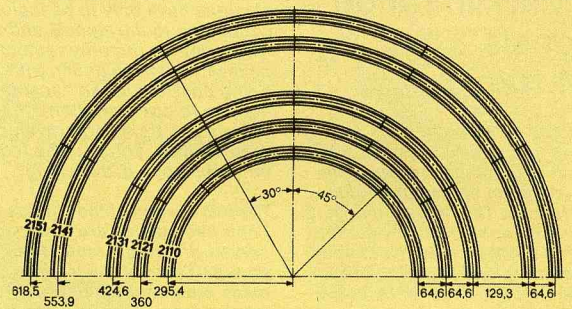

Straight track sections



2100 Full length = 7" (180 mm)



2102 Quarter length = 1 3/4" (45 mm)

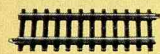

2101 Half length = 3 1/2" (90 mm)



2104 1/8 length = 7/8" (22.5 mm)

Straight make-up sections

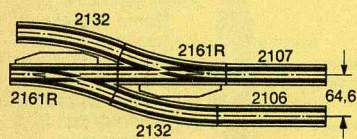

2106 Length 6 5/8" (168.9 mm)

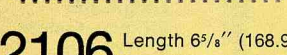

2107 Length 6 1/8" (156 mm)

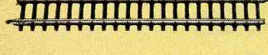

2108 Length 1 3/8" (35.1 mm)

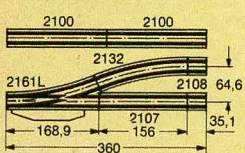

2108 Length 1 3/8" (35.1 mm)



2158 Crossing · Crossing angle 45° · Length of straight sections 3 1/2" (90 mm)



2159 Crossing · Crossing angle 22° 30' · Length of straight sections 6 5/8" (168.9 mm)

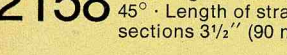

2159 Crossing · Crossing angle 22° 30' · Length of straight sections 6 5/8" (168.9 mm)

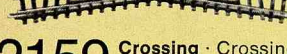

2159 Crossing · Crossing angle 22° 30' · Length of straight sections 6 5/8" (168.9 mm)



2190 Feeder track section, straight · Full length = 7" (180 mm) · 2 lead terminals marked "O" and "B" for connecting the track power lead



2192 Feeder track section, straight · Similar to 2190 but plus a built-in capacitor as suppressor · For 1 traction current circuit 1 x 2192 should be used



2191 Adapter track section, straight · Full length = 7" (180 mm) · Enables track sections of the 5100 and 5200 series to be connected to the 2100 series



2197 Uncoupler track section · Half length = 3 1/2" (90 mm) · For releasing automatic couplings · The uncoupling ramp between the rails can be operated either manually by the hand switch lever or from the control panel by means of the solenoids incorporated



2199 Switching track section, straight · Half length = 3 1/2" (90 mm)

Curved track sections

Radius 11 5/8" (295.4 mm) · Industrial circle

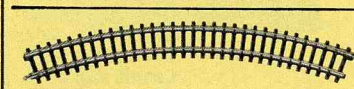

2110 Full length = 45°

Radius 16 3/4" (424.6 mm) · Standard circle II

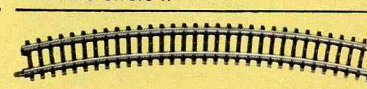

2131 Full length = 30°

Radius 14 1/8" (360 mm) · Standard circle I

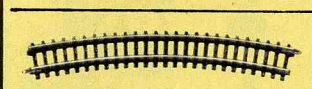

2121 Full length = 30°

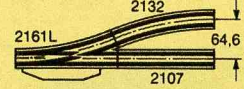

2132 Three-quarters length = 22° 30'



2123 Half length = 15°



2133 Half length = 15°

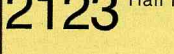

2124 Quarter length = 7° 30'



2134 Quarter length = 7° 30'

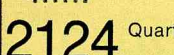

2129 Switching track section, curved · Half length = 15° · Radius 14 1/8" (360 mm)



2135 Eighth length = 3° 45'



2139 Switching track section, curved · Half length = 15° · Radius 16 3/4" (424.6 mm)



2139 Switching track section, curved · Half length = 15° · Radius 16 3/4" (424.6 mm)

Radius 21 3/4" (553.9 mm) · Large circle I

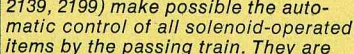

2141 Full length = 30°

Radius 24 3/8" (618.5 mm) · Large circle II

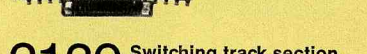

2151 Full length = 30°

With five different track circles, Märklin K-tracks are unsurpassed in the possible combinations they allow

K-turnouts for A. C. current K-track for layout extension

Märklin K-turnouts 2100 with sprung points

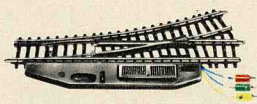
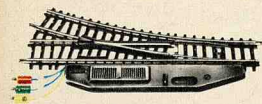

2161
Pair of electro-magnetic turnouts · Consisting of one right-hand and one left-hand turnout, both operated by

double solenoid · Working signal light · Frog angle $22^\circ 30'$ · Radius of branch track $17''$ (424.6 mm) · Length of straight section $6\frac{5}{8}''$ (168.9 mm)
Q = 60000

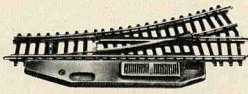
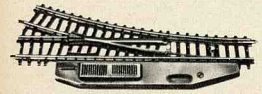

2164
Pair of manually-operated turnouts · Consisting of one right-hand and one left-hand turnout · Frog angle $22^\circ 30'$ ·

Radius of branch track $17''$ (424.6 mm) · Length of straight track $6\frac{5}{8}''$ (168.9 mm) · Operated by hand lever

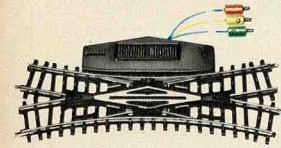

2160
Double slip switch · Crossing angle $22^\circ 30'$ · Radius $17''$ (424.6 mm) · Inside points operated by double solenoid actuated remotely · Additional hand lever for manual operation · Length of the straight track section $6\frac{5}{8}''$ (168.9 mm)

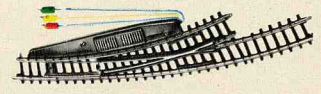
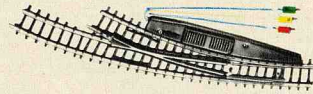
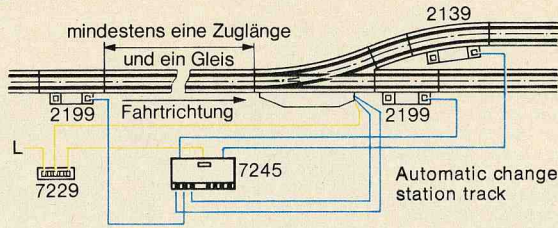
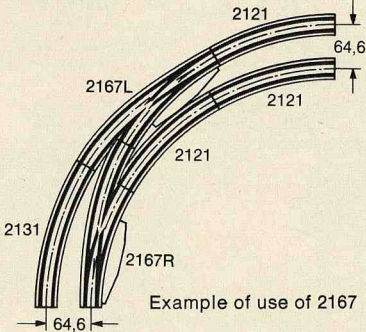

2167
Pair of electro-magnetic turnouts · Consisting of one right-hand and one left-hand inside turnout operated by

double solenoid · Length and curvature of the branch track as for section 2121 · Length of the outside track section $9\frac{1}{2}''$ (244.6 mm)

2170

Symmetrical three-way turnout operated by 2 double solenoids · 2 hand levers for manual setting of the two pairs of points · Length of straight track section $6\frac{5}{8}''$ (168.9 mm) · Frog angle $22^\circ 30'$ · Radius of branch track $17''$ (424.6 mm)

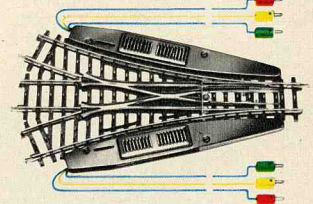

7391



Buffer stop of riveted steel construction · Snaps into the rails · Length $1\frac{1}{2}''$ (38 mm) · Wood fixing screws supplied

7500



Ground connection with terminal for connecting the ground wire to series 2100 track sections

7504



Connection for center conductor with terminal · At the rail joint, it is pushed on to the contact strip of the series 2100 track section

7522

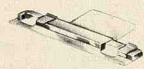

Insulation for the center conductor · Is inserted at the rail joint between the contact strip of series 2100 track section to provide a break in the circuit

7599



Flush wood screws for fixing plastic tracks · Packed in 200s

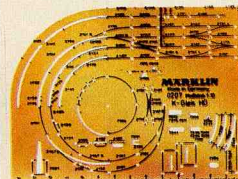

0207

Track planning template for Märklin K-tracks (series 2100) HO gauge · Track sections, turnouts, crossings, etc., are cut in the template to a scale of 1 : 10 and can easily be transferred on to paper with a sharp pencil

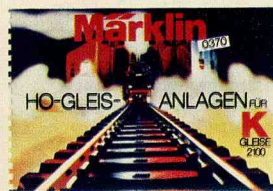

0371

Märklin track layouts, HO gauge, for K-tracks, series 2100 · An outstanding guide · 52 pages

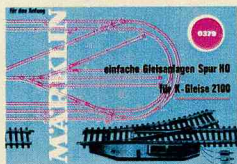

0379

Märklin track layouts, HO gauge, for K-tracks, series 2100 · Simple track plans · 20 pages · These booklets are described on page 22

HO track patterns for K-tracks from publications 0371 and 0379

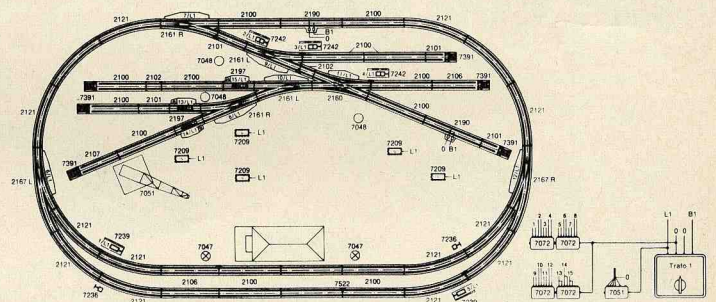

1 Layout 61" x 35" (155 x 90 cm) from 0371

16—2100	2—7047	9—7000	2—2161	3—7242	38—7115
4—2101	3—7048	3—7101	1—2167	6—7391	15—7117
2—2102	1—7051	1—7102	2—2190		38—7131
3—2106	4—7072	1—7103	3—2197		37—7132
1—2107	5—7209	1—7105			48—7135
14—2121	2—7236	8—7111	1 transformer 30 VA		37—7137
1—2160	2—7239	12—7112			

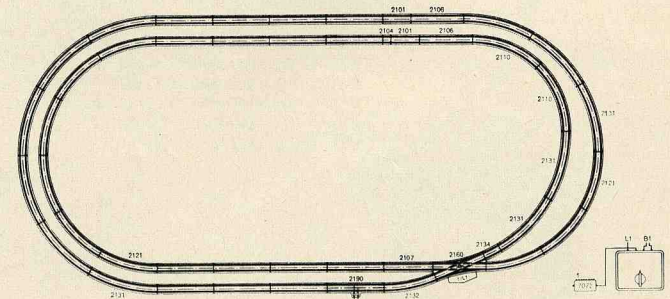

4 Layout 73" x 35" (186 x 90 cm) from 0379

15—2100	11—2131	1—7072	1—2107	1—2190	1—7102
2—2101	1—2132	1—7111	2—2110		1—7105
1—2104	1—2134	2—7121	9—2121		
2—2106	1—2160	1—7125	1 transformer 30 VA (16 VA)		

Every conceivable real railroad layout can be faithfully reproduced as a Märklin model

Märklin Signals 7200 for K + M tracks

The home light signals and siding signals of series 7200 are fitted with switches for the traction current, for independent control of the catenary system and the center contacts on the track. The masts of the signals, or the light-holder housing in the case of the siding signal 7242, can be set up individually or separately from the signal operation. The bracket 7230 is then required for fixing the masts. The ground connection for track sections of series 2100 is through the base plates which are supplied with them, or by wire, and for track sections of series 5100 and 5200 by wire.

7236

Color light distant signal · Signal lights change from amber/amber (caution) to green/green (proceed) using 4 bulbs · Only for connection to the home light signal 7239 · Used with fixing bracket 7230 and base plate · Width $5/8''$ (16 mm) · Length $1 1/8''$ (28 mm) · Height $2 5/8''$ (67 mm)

⚡ = 60202 green
60204 orange



7237

Color light distant signal · Signal light changes from amber/amber (caution) to amber/green (proceed with caution) using 4 bulbs · Only for connection to home light signal 7240 · With fixing bracket 7230 and base plate · Width $5/8''$ (16 mm) · Length $1 1/8''$ (28 mm) · Height $2 5/8''$ (67 mm)

⚡ = 60202 green
60204 orange

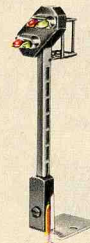

7238

Color light distant signal · Signal lights change from

amber/amber (caution) to green/green (proceed) or amber/green (proceed with caution), using 4 bulbs · Double solenoid operation for the amber/green setting · To be used with home light signal 7241 · With base plate · Width $1 1/8''$ (30 mm) · Length $2 3/4''$ (70 mm) · Height $2 5/8''$ (67 mm)

⚡ = 60202 green
60204 orange

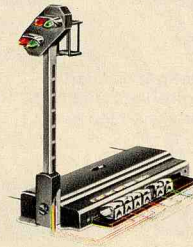

7239

Color light home signal · Signal lights change from red (stop) to green (proceed) with traction current

controlled by a double solenoid · 2 bulbs · Additional manually operated lever · With base plate · Width $1 1/8''$ (30 mm) · Length $2 3/4''$ (70 mm) · Height $3 1/2''$ (90 mm)

⚡ = 60201 red
60202 green

Insulators for center track conductors, connections for central track conductors and instructions are included with home signals 7239, 7240 and 7241.

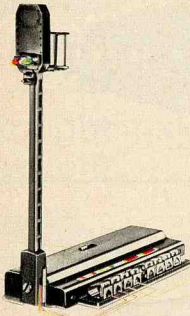

7240

Color light home signal · Signal lights change from red (stop) to green/amber (proceed with

caution), with control of the traction current by operation of a double solenoid · 3 bulbs · Additional manually operated lever · With base plate · Width $1 1/8''$ (30 mm) · Length $2 3/4''$ (70 mm) · Height $3 1/2''$ (90 mm)

⚡ = 60201 red
60202 green
60204 orange

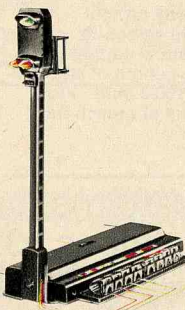

7241

Color light home signal · Signal light changes from red (stop) to green (proceed) or green/amber (proceed

with caution) with control of the traction current by double solenoid, with a third solenoid in addition for the green/amber setting · 3 bulbs · Additional two manually operated switch levers · With base plate · Width $1 1/8''$ (30 mm) · Length $3 3/4''$ (95 mm) · Height $3 1/2''$ (90 mm)

⚡ = 60201 red
60202 green
60204 orange

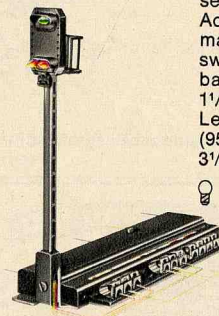

7230

Fixing bracket · Is required if the mast of light signals 7238, 7239, 7240, 7241 and the siding signal 7242 are set up separated from the solenoid drive

7242

Siding signal, dwarf version · Signal lights change from red/red (stop) to white/white (proceed with extreme caution) and traction current is controlled by double solenoid operation · Two light bulbs provide the signal lights · Additional manually operated switch lever · Width $1 1/8''$ (30 mm) · Length $2 3/4''$ (70 mm) · Height $3/4''$ (18 mm)

⚡ = 60200

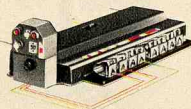

7245

Universal remote control switch with 2 single-pole switches and a change-over switch for various circuits · It can be given a number of functions (up to three operations simultaneously) which it then carries out automatically and reliably, for example, causing a moving train to switch station lighting on an off, overriding the control by signal of trains travelling in the opposite direction and many more · Many ways of using it are shown in the Signal Manual 0361 and in the installation instructions · Operated by double solenoid · Can be actuated by switching track section, control panel or manually operated switch lever · Width $1 1/8''$ (30 mm) · Length $2 3/4''$ (70 mm) · Height $3/8''$ (8 mm)



7539 for K-tracks only

Color light home signal · Signal light changes from red (stop) to green (proceed) by manual operation, with simultaneous control of the traction current in the center track conductor which is permanently connected · Additional track section $3 1/2''$ (90 mm) long with interrupted center conductor · Width $2''$ (50 mm) · Length $3 1/2''$ (90 mm) · Height $3 1/2''$ (90 mm)

⚡ = 60001 red
60002 green

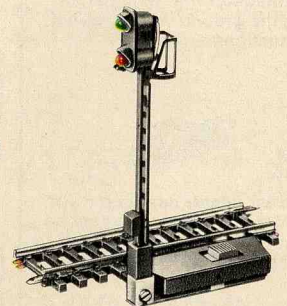
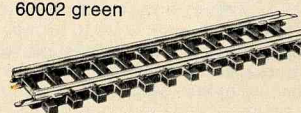

0361

Märklin Signal Manual for K-tracks · For description, see page 22

Controlled railroad operation is unthinkable without signals



Building large bridges is still as fascinating today as it was in the railroad's pioneering age

Märklin catenary system for M-tracks 5100/5200

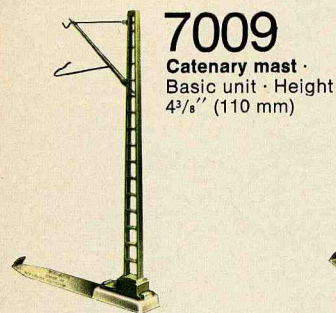

7009
Catenary mast · Basic unit · Height 4 3/8" (110 mm)



7010
Feeder mast for supplying current, with 2 leads and instructions for using the catenary system · Height 4 3/8" (110 mm)

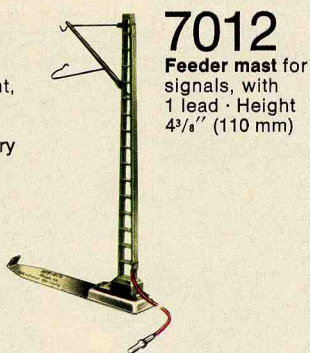

7012
Feeder mast for signals, with 1 lead · Height 4 3/8" (110 mm)

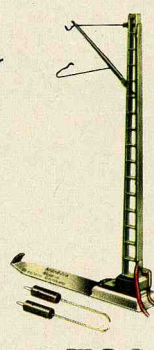

7201

7005

Catenary set for train control for signals of the 7000 series which are not mounted on tower masts · Consisting of 2 feeder masts 7012, 2 insulator sections 7022 and 2 overhead contact wire sections 7014

The electric locomotives can pick up their current from the overhead contact wire with the same reliability as from the stud contacts. All that has to be done is to switch over a small lever on the locomotive. With the Märklin system it makes no difference in which direction the locomotive is placed on the track. It is advisable to connect the catenary system to a separate transformer; two trains can then run independently of one another on the same track using the catenary system and the contact studs.

Feeder mast for supplying current, with 2 permanently connected leads, one red, one brown · Built-in capacitor to suppress radio interference · Including instructions for setting up the catenary system · Height 4 3/8" (110 mm)

The overhead contact wires with their tensioning and cross span connectors are arranged exactly like the real thing. That is why the Märklin catenary system appears so realistic, both when it is above open tracks and particularly when it is spanning station tracks. The contact wire sections are for use both with M-tracks and K-tracks. The sprung contact wire holders on the masts ensure reliable contact with the contact wires.

The ingenious snap-plug connectors enable the contact wire sections, e.g. 7013 and 7023, always to be pushed through to the required length.

The contact wires are flexible and can be adapted to any curve without the use of any auxiliary equipment. The longest contact wire section 7019 is intended for long straight runs.

Using the tower masts 7021 and the cross spans 7016, any width of track can be spanned. 4 tracks need one cross span and 2 tower masts and each extra 4 tracks need a further cross span and tower mast. For single tracks passing by a tower, but not between two towers, the overhead contact wires can be mounted on the cantilever arms 7525.

Märklin catenary system for K+M tracks

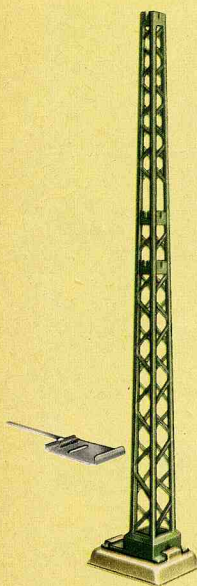

7021
Tower mast with recesses for hooking in the cross spans 7016 and 7017 and the cantilever support arm 7525 for the overhead wire · For tower mast with arc light, see page 76



7511
Bridge mast · For attaching to the side of plastic bridges and ramps · Height 3 7/8" (97 mm)



7003
Catenary system feeder wire for connection to signals when tower masts are used and for supplying current to any point · Length 24" (600 mm)

7004

Fastening kit · Consisting of 5 bolts, 5 nuts and 5 washers · Used only in exceptional cases where it is not possible to make a reliable contact by the usual method of assembly

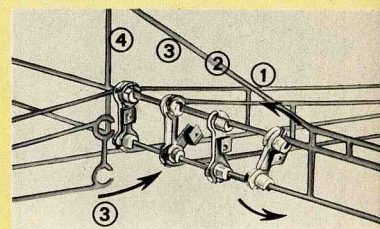

7006

Contact wire insulator · For insulating sections of contact wire from cross spans · One required for each track and cross span · 5/8" x 1/4" (15 x 6 mm)



7013
Contact wire section for plug connection, especially for turnouts · Length 9 1/2" (240 mm)

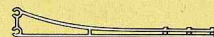

7014
Contact wire section · Female portion (for plug connection) · Length 4 1/2" (115 mm)



7015
Contact wire section · Male portion (for plug connection) · Length 4 1/2" (115 mm)

All contact wire sections are nickel plated.



The catenary system brings the system even nearer to the real thing

Märklin catenary system for K-tracks 2100

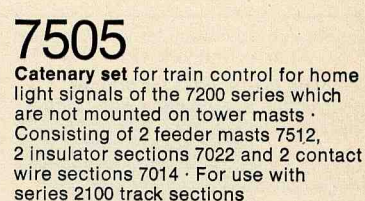
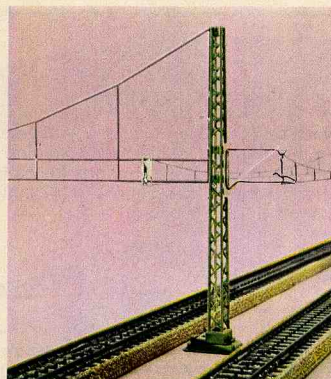
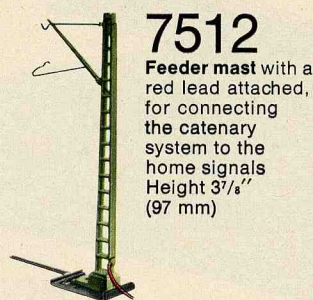

Märklin catenary system for K+M tracks

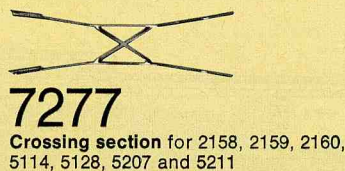
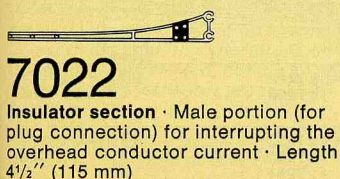
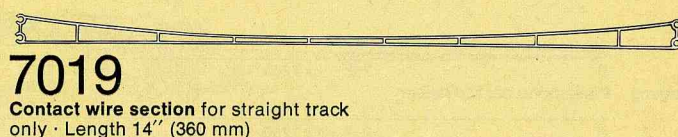
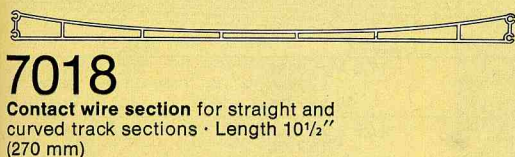
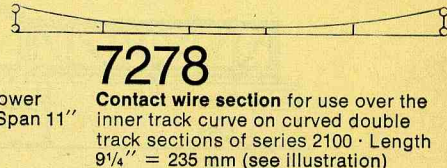
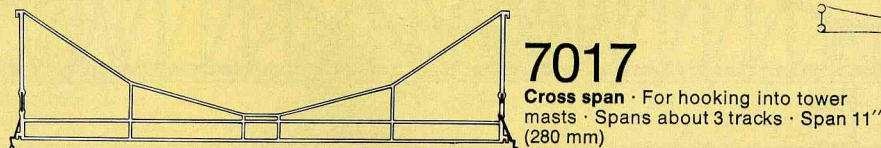
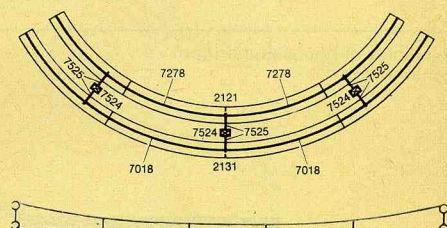
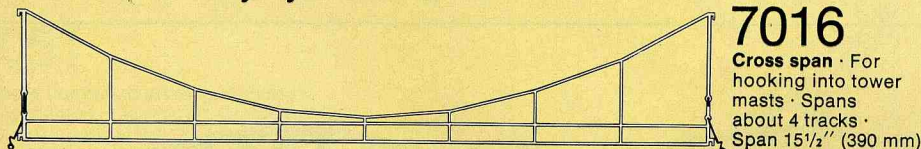

All contact wire sections are nickel-plated.

Using contact wire sections 7014, 7015 and 7023 it is possible to make up any length from 7" to 14" (177—360 mm).

The plug connections can be strengthened if necessary with the fastening kit 7004 (see illustration).

The stylish and reliable catenary system is available for K-tracks and for M-tracks

Märklin bridges in plastic for K+M tracks

With the Märklin bridge parts any size or combination of bridges or ramps can be built. The pier constructional elements 7252 and 7253, which fit together like building blocks, enable piers of any height to be built up in steps of $\frac{1}{4}$ " (6 mm). By using the base plate 7251 in conjunction with the base plate 7250, it is even possible to raise the height by steps of $\frac{1}{8}$ " (3 mm) at a time. For fixing the pier sections on the base plate and fixing the sections together, the use of button head screws is recommended.

Complete instructions for bridges construction are included with bridges 7262 and 7263.

There is a very interesting example of bridge construction on page 67.

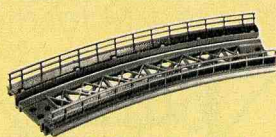

7267 K+M

Curved ramp section · Grey · Radius of curvature $14\frac{1}{8}$ " (360 mm) · For use with plastic or metal tracks · 3 clips for fastening the K-track · Length and radius as for track sections 2121 and 5100

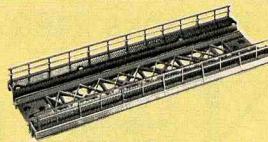

7268 K+M

Straight ramp section · Grey · For use with plastic or metal tracks · 3 clips for fastening the K-track · Length 7" (180 mm)

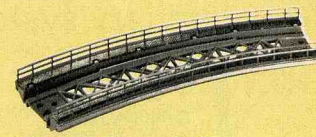

7269 for M only

Curved ramp section · Grey · Radius of curvature 17" (437.4 mm) · For metal tracks 5200 only · Angle subtended 30°

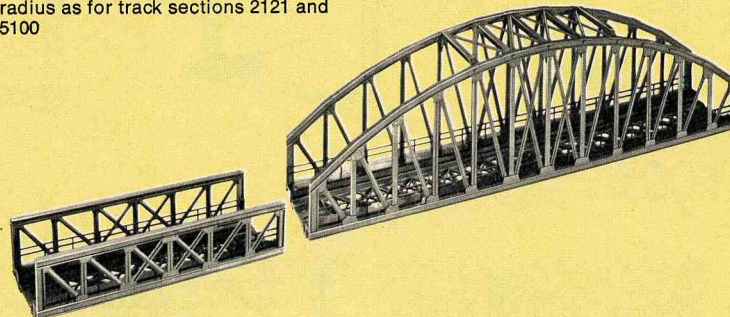

7262 K+M

Truss bridge · Grey · Can be used on its own or with arch bridge 7263 · For use with plastic or metal tracks · 3 clips for fastening the K-tracks and instructions for building the bridge · Height $1\frac{3}{4}$ " (45 mm) · Length 7" (180 mm)

7263 K+M

Arch bridge · Grey · For use with plastic or metal tracks · 6 clips for fastening the K-tracks and instructions for building the bridge · Height $4\frac{1}{2}$ " (117 mm) · Length $14\frac{1}{8}$ " (360 mm)

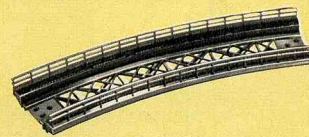

7569 for K only

Curved ramp section · Grey · Radius of curvature $16\frac{3}{4}$ " (424.6 mm) · For plastic tracks only (Standard Circle II, see page 64) · 3 clips for fastening the K-track · Length and radius as for track section 2131

7234

Base plate · For fixing signal masts of the 7200 series to bridges



7250

Base plate · $\frac{1}{10}$ " (2.5 mm) high · Light brown · Can be used as foundation



7251

Base plate · $\frac{1}{8}$ " (3 mm) high · Light brown · To be used only in conjunction with 7250



7252

Pier · $\frac{1}{4}$ " high (6 mm) · Grey · Suitable for building ramps with $\frac{1}{4}$ " (6 mm) rise from one pier to the next



7253

Pier · $1\frac{1}{4}$ " (30 mm) high · Grey



Examples of ramps and bridge construction

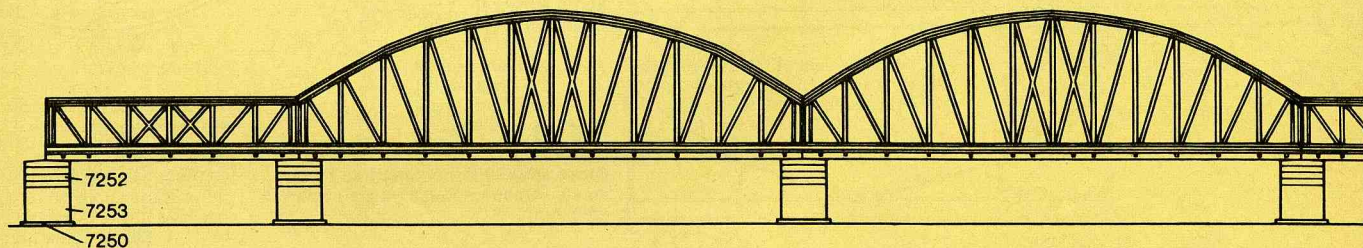

6 mm Steigung	Pfeilerhöhe bei M-Gleisen	0	2,5 = 1 x 7250	5,5 = 1 x 7250 1 x 7251	11,5 = 1 x 7252 1 x 7250 1 x 7251	17,5 = 2 x 7252 1 x 7250 1 x 7251	23,5 = 3 x 7252 1 x 7250 1 x 7251
6 mm Steigung	Pfeilerhöhe bei K-Gleisen	0	2,5 = 1 x 7250	2,5 = 1 x 7250	8,5 = 1 x 7252 1 x 7250	14,5 = 2 x 7252 1 x 7250	20,5 = 3 x 7252 1 x 7250
9 mm Steigung	Pfeilerhöhe bei M-Gleisen	0	2,5 = 1 x 7250	5,5 = 1 x 7250 1 x 7251	11,5 = 1 x 7252 1 x 7250 1 x 7251	20,5 = 3 x 7252 1 x 7250	29,5 = 4 x 7252 1 x 7250 1 x 7251
9 mm Steigung	Pfeilerhöhe bei K-Gleisen	0	2,5 = 1 x 7250	2,5 = 1 x 7250	8,5 = 1 x 7252 1 x 7250	17,5 = 2 x 7252 1 x 7250 1 x 7251	26,5 = 4 x 7252 1 x 7250

Today's engineers have at their disposal highly developed construction techniques

Remote controlled turntable

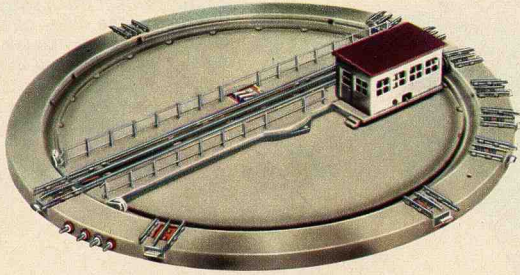

7186

Turntable set · Consisting of turntable with outside diameter of 14 1/4" (360 mm) turning in either direction by remote control, with reversing switch and lead · Current is automatically cut off from all tracks not in contact with the turntable track



Adapter track section 2191 (see page 64) enables K-track 2100 to be connected to the turntable 7186.

Locomotive roundhouse

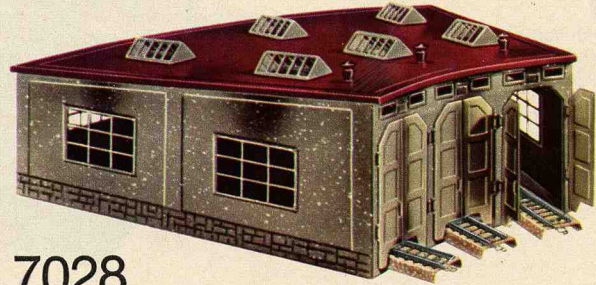

7028

Locomotive roundhouse with 3 automatically closing doors for 3 tracks · (Track sections not included) · Size 18" x 14 1/2" (460 x 370 mm) · Height 5 1/4" (135 mm)

A turntable and roundhouse help to complete your model railroad. The turntable is used to enable locomotives to be turned round on the spot, so that they have the smoke stack in front in the direction of travel. Most locomotives are authorised to travel faster forwards than backwards. In addition, the turntable is used to distribute the locomotive to the 3 or 6 tracks in the roundhouse, or to guide them to the right track for their departure. The current is cut off all tracks not in contact with the turntable track.

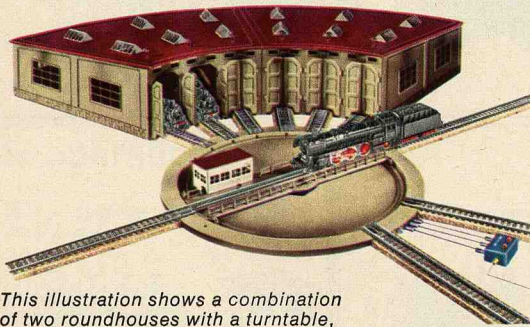

This illustration shows a combination of two roundhouses with a turntable, to give a realistic reproduction of the original.

Suggested combination of roundhouse 7028 with three-way turnout 5214.

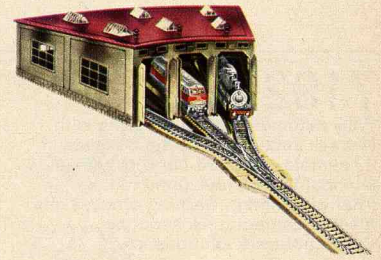

Remote controlled slewing crane

7051

Remote controlled slewing crane with lifting magnet · One motor rotates the boom, another raises and lowers the load · Load hook and lifting magnet enable iron or iron-containing objects to be transferred by remote control · Boom adjustable manually for elevation · Working light in control cab · Height 10 1/4" (260 mm) · Base 3 1/2" x 3 1/2" (90 x 90 mm) · 1 combined control and switch panel · Price does not include locomotive, cars or track

⚡ = 60000

If you want to load and unload your freight trains properly, you need this crane. The lifting magnet will, of course, lift only iron, but other things besides "scrap iron" or "pig iron" can still be loaded. Screw a couple of small screws inconspicuously into wood and everyone will be surprised to see the magnet lift a wooden crate or wooden planks out of a road truck on to a freight car. A slewing crane not only introduces new, interesting variations into the operation of a model railroad, since all the operations can be remotely controlled, but it also adds realism to the transport procedure.



A locomotive having an in-service weight of one hundred and twenty tons can be turned round on the spot only by means of a turntable

Grade crossings for M-tracks

7292 M

Grade crossing with half-barriers, for metal tracks. The set consists of two solenoid-operated barriers, each with two red warning lights, which come on when the barriers are closed, and a set of contact track sections (1½ straight track sections long). Size of each base: 5⅜" × 3¾" (137 × 95 mm)

⊙ = 60201

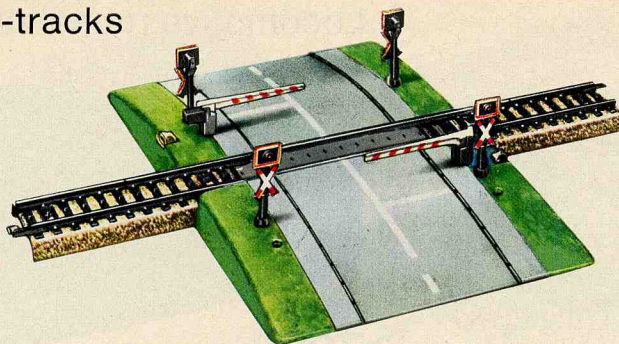

Guarded grade crossings with automatic barriers. As soon as the train approaches the crossing and runs on to the contact track sections, the barriers close. They open again only after the last car has left the contact track section beyond the crossing.

7293 M

Extension set for grade crossing 7292. One required for each additional parallel track. Consisting of one set of contact track sections (1½ straight track sections long) and an adapter adjustable between 1⅝" (43 mm) and 3" (78 mm), which is fitted between the two tracks

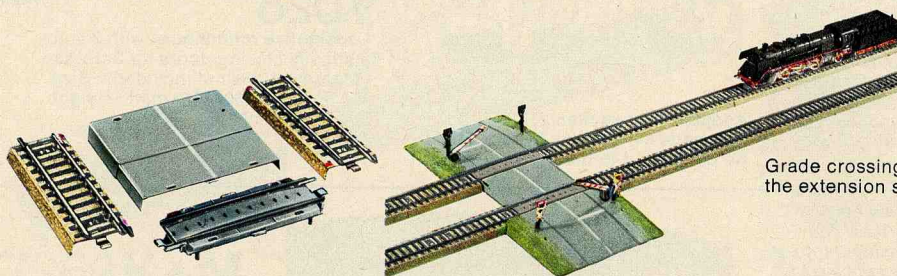

Grade crossing 7292 supplemented by the extension set 7293

7192 M

Fully automatic grade crossing with M-track sections. The set consists of 2 solenoid-operated barriers with an attendant's box (designed to take interior lighting), warning crosses and a set of contact track sections (2 straight track sections long)

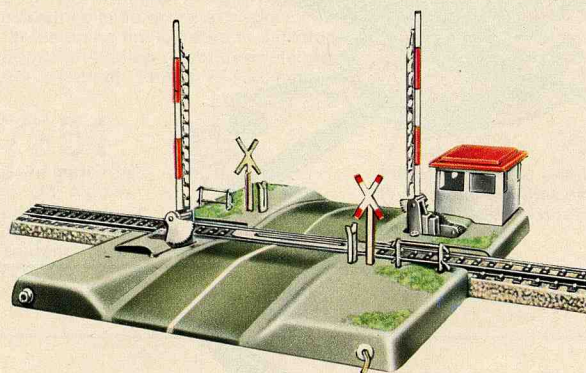

The grade crossing 7192 in conjunction with the extension set 7193 can also be arranged for use with more than one track. In this case, it still operates automatically.

7193 M

Extension set for the fully automatic grade crossing 7192, one required for each additional parallel track. Consisting of a set of contact track sections and adapter, which can be fitted between the tracks

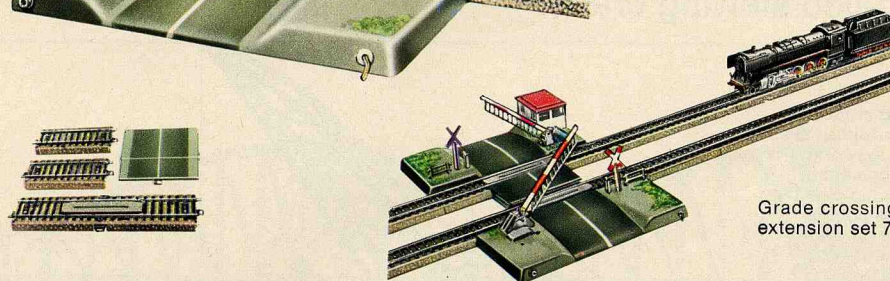

Grade crossing 7192 supplemented by extension set 7193

7390 M

Mechanically operated grade crossing for a single-track line using M-track sections. The barriers are closed by floating bars pressed down by the wheels of the passing train. The length of the track section in the grade crossing is the same as that of track section 5106. Base 4¾" × 7" (120 × 180 mm)

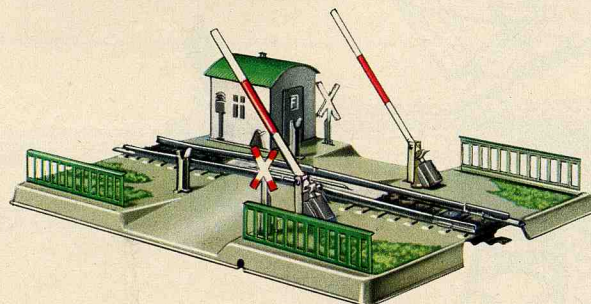

Contact track sections



5115

straight · Length 7" (180 mm)



5116

curved · Radius 14⅞" (360 mm)

*These M-track sections 5115 and 5116 are for extending the contact section of grade crossing 7192 and 7292. The contact section can be extended **only** with track sections 5115 and 5116.*

Grade crossings should be equipped with fully automatic safety devices

Grade crossing for K-track

7592 K

Grade crossing with half barriers for K-tracks. Set consists of 2 solenoid-operated barriers each with 2 red warning lights which come on when the barriers close, and a set of contact track sections (1 1/2 straight track sections long). Size of each base 5 3/8" x 3 3/4" (137 x 95 cm)

Q = 60201

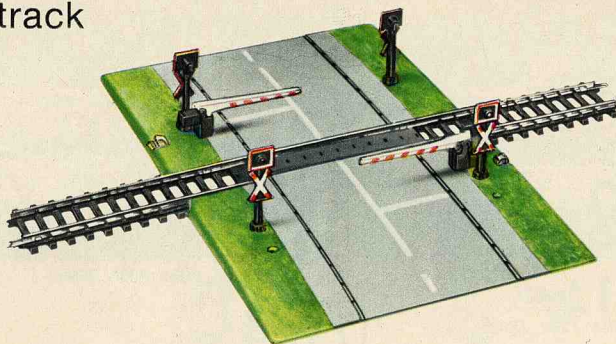

7593 K

Extension set for grade crossing 7592. Is required for each extra parallel track. Consisting of a set of contact track sections (1 1/2 straight track sections long) and an adapter adjustable in length between 1 5/8" (43 mm) and 3" (78 mm) for fitting between the two tracks

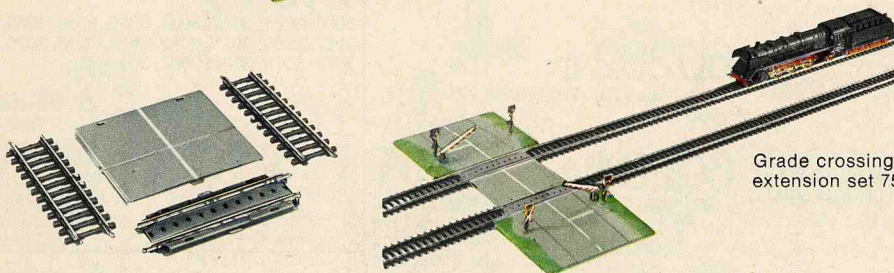

Grade crossing 7592 supplemented by extension set 7593

Accessories for remote operation

Circuit diagram for 7210 (Switch 3 closed)

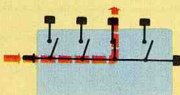

7210

Control panel for distributing current to 4 different traction or lighting circuits by indicator push buttons. Length 3 1/8" (80 mm) · Width 1 3/4" (40 mm)

Circuit diagram for 7211 (Switch 3 closed)

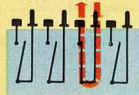

7211

Control panel for switching 4 different traction or lighting circuits on and off by indicator push buttons. Length 3 1/8" (80 mm) · Width 1 3/4" (40 mm)



7209

Distributor panel · With 11 single-pole sockets · Size 2" x 3/4" (50 x 20 mm)



7229

Distributor panel with 5 lead terminals connected in series. Length 1 1/2" (38 mm) · Width 3/8" (10 mm)



7072

Control panel with 8 sockets for connecting 4 items operated magnetically by double solenoids. The position of the push buttons indicate the settings of the signals, turnouts, etc. Length 3 1/8" (80 mm) · Width 1 3/4" (40 mm)

Warning bells for tracks of all gauges



7221

Warning bell with two-tone ring. Solenoid-operated. Operating voltage 16 V. Operated from control panel. Height 1 5/8" (42 mm) · Diameter 2" (50 mm)



7222

Warning bell with two-tone ring. Operated by hand crank. Height 4" (100 mm) · Base diameter 1 3/4" (40 mm)



No Märklin model railroad should be without remote control - faithfully reproduced from the central control point onwards

Accessories for Märklin HO gauge locomotives and other items

Light bulbs

for items as follows:

60000 

2161, 3015, 4044, 4077, 4081, 5117, 5128, 5137, 5140, 5202, 7036, 7037, 7038, 7039, 7040, 7041, 7042, 7051, 7077, 7191, 7280, 7281, 7282, 7283, 7284

60001 

3071, 3076, 7079, 7188, 7339, 7539 (red)

60002 

7188, 7339, 7539 (green)

60010 

3000, 3003, 3016, 3021, 3031, 3064, 3065, 3072, 3095, 4018, 4506, 5113, 7046, 7047, 7048, 7323

60015 

3022, 3030, 3034, 3035, 3037, 3038, 3039, 3040, 3041, 3043, 3044, 3050, 3054, 3055, 3060, 3066, 3067, 3068, 3071, 3074, 3075, 3076, 3077, 3078, 3084, 3085, 3086, 3089, 3092, 3093, 3094, 3096, 3098, 4053, 4060, 4089, 6631, 7197, 7320, 7322, 7324, 7325

60020 

7073, 7074

60200 

7242

60201 

7239, 7240, 7241, 7292, 7592 (red)

60202 

7187, 7236, 7237, 7238, 7239, 7240, 7241 (green)

60204 

7187, 7236, 7237, 7238, 7240, 7241 (orange)

Rubber tires

for the following locomotives:

7152

3085, 3086, 3089, 3092, 3093, 3094, 3098

7153

3003, 3015, 3016, 3022, 3030, 3034, 3035, 3037, 3038, 3039, 3040, 3041, 3043, 3050, 3054, 3064, 3065, 3084, 3095, 3096

7154

3000, 3021, 3031, 3044, 3055, 3060, 3066, 3067, 3068, 3071, 3072, 3074, 3075, 3076, 3077, 3078, 3080, 3087, 3090

Current pick-up shoe

for the following locomotives, cars, lighting sets:

7164

3016, 3022, 3034, 3035, 3037, 3038, 3039, 3040, 3041, 3043, 3050, 3054, 3055, 3066, 3067, 3068, 3071 front, 3072, 3074, 3075, 3076, 3077, 3084, 3085, 3096

7175

3015, 3071 rear, 4018, 4044, 4053, 4077, 4081, 4089, 7197, 7198, 7320, 7322, 7323, 7324

7183

3021

7185

3000, 3003, 3030, 3031, 3044, 3060, 3064, 3065, 3078, 3080, 3086, 3087, 3089, 3090, 3092, 3093, 3094, 3095, 3098, 4060

Reverser unit spring

7194

Pack with 5 springs for reversing switch

Instructions for fitting rubber tires, current pick-up shoes, light bulbs and reverser unit springs are given in the "Instructions for use".



7218

Pantograph, double arm · 1 cheese-head screw



7219

Pantograph, single arm · 1 cheese-head screw · The catenary system must be very carefully set up when 7219 is used



60030

Pair of carbon brushes for most HO gauge locomotives

60035

Pair of carbon brushes for locomotive 3015

60146

Pair of carbon brushes for locomotives 3084 and 3085



7226

Smoke set · Consisting of smoke unit (to fit locomotives 3084 and 3085), replacement steam pipe, cleaning wire, pair of tweezers and capsule of smoke fluid



7227

Smoke set · Consisting of smoke unit (to fit locomotives 3092 and 3093) with a capsule of smoke fluid



0241

Smoke fluid in plastic capsule as refill for smoke sets 7226 and 7227



7199

Bottle of oil · Contains about 1 fluid ounce (10 cm³) of lubricating oil for locomotives and cars

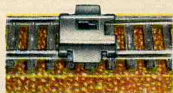

7001

Coupling gauge made of nickel-plated steel sheet, for checking locomotive and car couplings

7195

Number plate set · For identifying turnouts and signals in the track layout · Contents: 12 boxes with slots to hold the numbers 1—24 which are provided

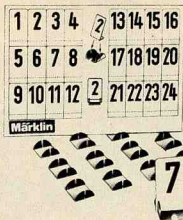

7224

Locomotive positioning ramp · Made of plastic · Facilitates placing multi-axle rolling stock on the track · Length 12" (300 mm) · Height 1" (25 mm)

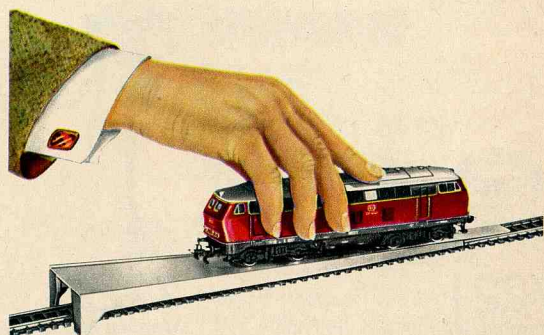

Märklin accessories increase the realism of your layout

Electric lighting on train

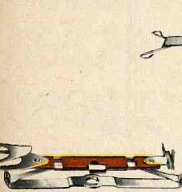
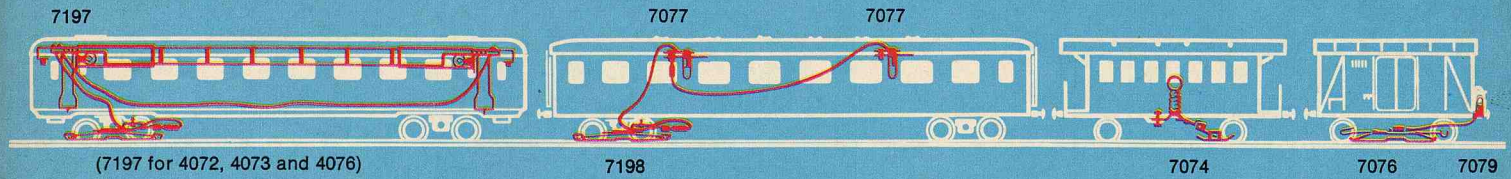

7076
Pick-up shoe for taillight 7079 when used on passenger coaches 4000 and 4040 and on two-axle freight cars

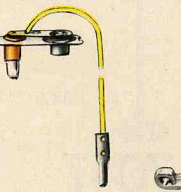

7077
Interior lighting set for most long-distance coaches. With socket for connecting additional bulbs. Light bulb
☞ = 60000

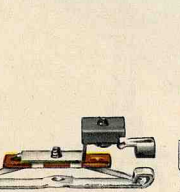

7198
Pick-up shoe for interior lighting set 7077
☞ = 7175



7079
Taillight with bulb. Clips on to buffer. For use on cars with metal buffers only. For connecting up, it requires 7074, 7076, 7077 or 7198
☞ = 60001 (red)

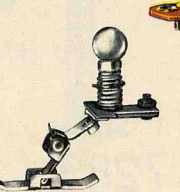

7074
Interior lighting set for passenger coaches 4004, 4005, 4079 and 4080. With socket for connecting additional lights. Light bulb
☞ = 60020

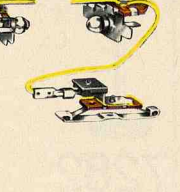

7322
Interior lighting set for TEE coach 4090. Consisting of pick-up shoe 7198, 2 lamp sockets and 2 bulbs. Instructions for installation are included
☞ = 7175 ☞ = 60015

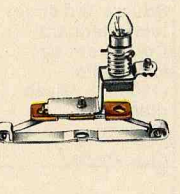

7323
Interior lighting set for coaches 4007 and 4008. Light bulb
☞ = 7175 ☞ = 60010

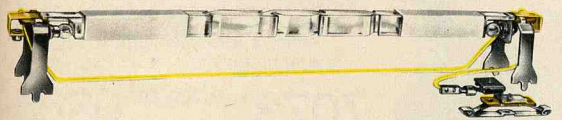

7197
Interior lighting set for long-distance coaches 4072, 4073 and 4076. Consisting of pick-up shoe 7198, light

diffuser, 2 lamp sockets and 2 bulbs. Instructions for installation are included
☞ = 7175 ☞ = 60015

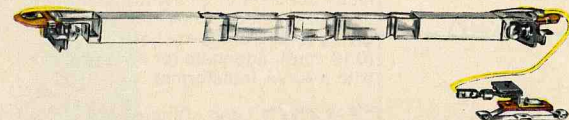

7320
Interior lighting set for TEE coaches 4085, 4087 and long-distance coaches 4049, 4054, 4064, 4066, 4069 and 4078.

Consisting of pick-up shoe 7198, light diffuser, 2 lamp sockets and 2 bulbs. Instructions for installation are included
☞ = 7175 ☞ = 60015

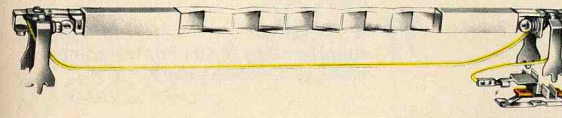

7324
Interior lighting set for long-distance coaches 4091, 4092, 4093 and 4094 not marked "A" on bottom of coach. Consisting of pick-up shoe, light

diffuser, 2 lamp sockets and 2 bulbs. Instructions for installation are included
☞ = 7175 ☞ = 60015

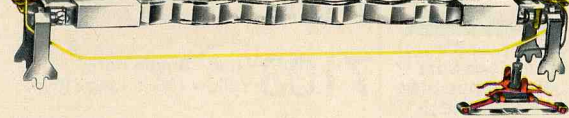

7325
Interior lighting set for long-distance coaches 4091, 4092, 4093 and 4094 marked "A" on bottom of coach and TEE coaches 4095, 4096, 4097 and

4099. Consisting of pick-up shoe, light diffuser, 2 lamp sockets and 2 bulbs. Instructions for installation are included
☞ = 41494 ☞ = 60015



Märklin makes smoke come out of the smoke stacks

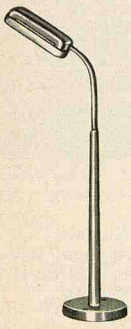

7280
Street lamp standard · Height 4⁵/₈" (117 mm) · Base diameter 1" (25 mm)
☉ = 60000

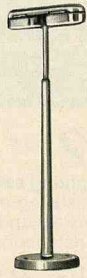

7281
Station platform lamp standard · Double armed · Height 3³/₄" (97 mm) · Base diameter 1" (25 mm)
☉ = 60000

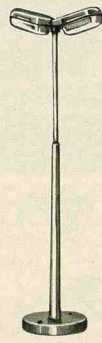

7282
Square and street lamp standard · Double armed · Height 4³/₄" (120 mm) · Base diameter 1" (25 mm)
☉ = 60000

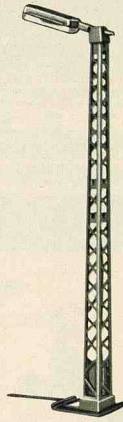

7283
Lattice mast light · Mounted on a lattice mast · With base plate for mounting on the K-tracks · Can be used with catenary system · Height 6³/₄" (170 mm)
☉ = 60000



7284
Sidewalk lamp standard · Height 2¹/₂" (63 mm) · Base diameter 3/5" (15 mm)
☉ = 60000

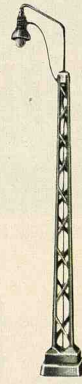

7046
Arc light with lattice mast · Can be used with catenary system for M-tracks · Height 8" (205 mm) · Base 1" x 1¹/₄" (23 x 32 mm)
☉ = 60010



7047
Lamp standard · Height 5" (127 mm) · Base diameter 1" (27 mm)
☉ = 60010

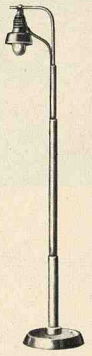

7048
Arc light · Height 6¹/₈" (156 mm) · Base diameter 1¹/₈" (29 mm)
☉ = 60010

Commonly used electrical lead colors for Märklin circuits

 Red = Traction current connection (from transformer to center rail conductor or catenary contact wire)

 Brown = Earth lead from tracks, lighting sockets or control panel to transformer

 Yellow = Lighting and solenoid-operated items

 Blue = Earth return lead from solenoid-operated items to control panel or switching track (with green, red and orange plugs)

Electrical leads

The copper conductor in these stranded leads consists of 24 separate strands each of diameter 0.004" (0.10 mm), giving a total cross-section of 0.03 sq." (0.19 mm²), adequate for all loads, even with a 40 VA transformer.

7100 Lead · Single core · Grey · 33 ft. long (10 m)

7101 Lead · Single core · Blue · 33 ft. long (10 m)

7102 Lead · Single core · Brown · 33 ft. long (10 m)

7103 Lead · Single core · Yellow · 33 ft. long (10 m)

7105 Lead · Single core · Red · 33 ft. long (10 m)

Sleeves



7111 = brown
7112 = yellow
7113 = green
7114 = orange
7115 = red
7117 = grey

Plugs with side sockets



7131 = brown
7132 = yellow
7133 = green
7134 = orange
7135 = red
7137 = grey

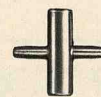

7140

Adapter for connecting two sleeves or sockets and as an additional means of connecting two plugs

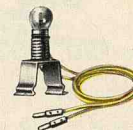

7073

Lamp socket with bulb and lead, for stations, freight sheds, etc.

☉ = 60020



7000

Staples · Bag of 50 · For fastening leads to a wooden base

At night the passenger gets the impression of a romantic sea of lights, the railroadman sees order with a purpose

Transformer · Output 16 VA · Traction voltage adjustable between 4 V and 16 V · Lighting voltage 16 V · Plastic casing · Weight 2½ lbs. (1,2 kg) · Dimensions 5" × 5⅜" × 3" (125 × 135 × 75 mm)

For special duty, we stock a transformer under the following numbers:

- 6660** 100 volt Japan
- 6666** 110 volt
- 6667** 110 volt USA
- 6669** 240 volt England
- 6671** 220 volt

When ordering please quote the number corresponding to the required mains voltage.

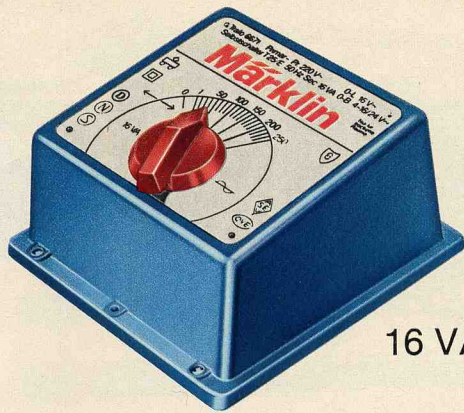

16 VA

Transformer · Output 30 VA · Traction voltage adjustable between 4 V and 16 V · Lighting voltage 16 V · Plastic casing · Red pilot lamp · Weight 4½ lbs. (2,1 kg) · Dimensions 6¼" × 5⅜" × 3" (158 × 135 × 75 mm)

Q = 60015

For special duty, we stock a transformer under the following numbers:

- 6620** 100 volt Japan
- 6625** 125 volt
- 6629** 240 volt England
- 6631** 220 volt
- 6152** 110 volt
- 6153** 110 volt USA

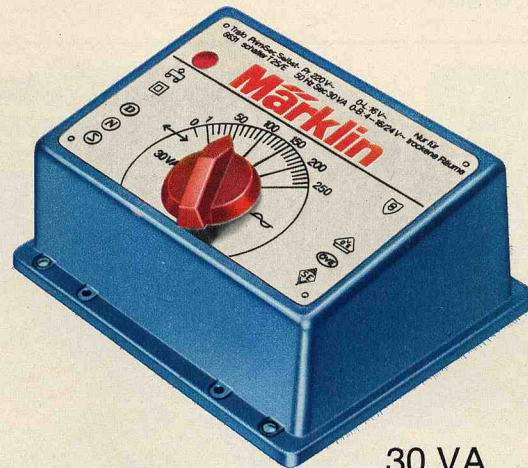

30 VA

When ordering please quote the number corresponding to the required mains voltage.

Transformer for lighting
40 VA

- 6611** 220 volt

Transformer for lighting and for solenoid-operated items · Output 40 VA · Output voltage 16 V A.C. approx. · Plastic casing · Weight 4 lbs. 6 oz. (2,0 kg) · Dimensions 6¼" × 5⅜" × 3" (158 × 135 × 75 mm)

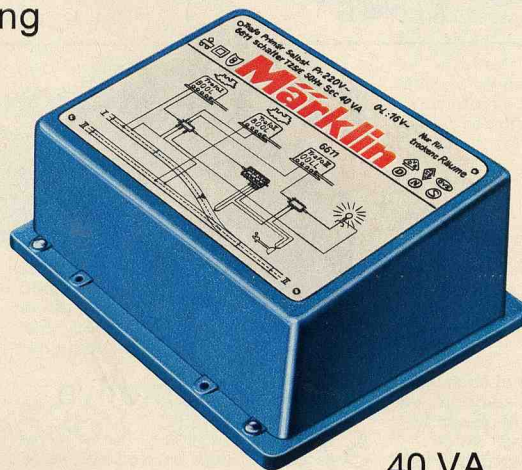

40 VA

The heavy-duty Märklin transformers

The reliable insulation, tested at several thousand volts, makes every Märklin transformer absolutely safe. Furthermore, a built-in circuit breaker switches off the current if there is a short-circuit anywhere in the layout, or if the transformer is overloaded. The transformer can be plugged into the mains supply just as easily as any standard lamp.

The speed of the locomotives increases with the traction voltage, i.e. they go faster as the red control knob is turned to the right and slower as it is turned to the left. If the control knob is turned momentarily past the zero position on the left, the 24 V reversing circuit is activated and the locomotive reverses direction (the "engineer" is built-in).

We guarantee trouble-free operation of our railroads only when genuine Märklin transformers are used.

Märklin 16 VA and 30 VA transformers have connections for trains and lighting/solenoid-operated items.

To be connected to AC mains supply only

Power requirements for locomotives and lights

Examples:
This is how you can work out how many items can be connected to the transformers: the 3-axes tank locomotive 3000 takes about 9 VA, the express diesel locomotive 3021 and the heavy express steam locomotive 3085 each about 12 VA. Any transformer capacity left after supplying the locomotive can be used for lighting the trains or layout, with 1 VA counted as the requirement for each bulb.

The transformer in the gift sets on page 27 has the same advantages as the transformer described here. The only difference is its lower output.

Uncoupling locomotives, reversing? Obviously by remote control using Märklin transformers

Train sets

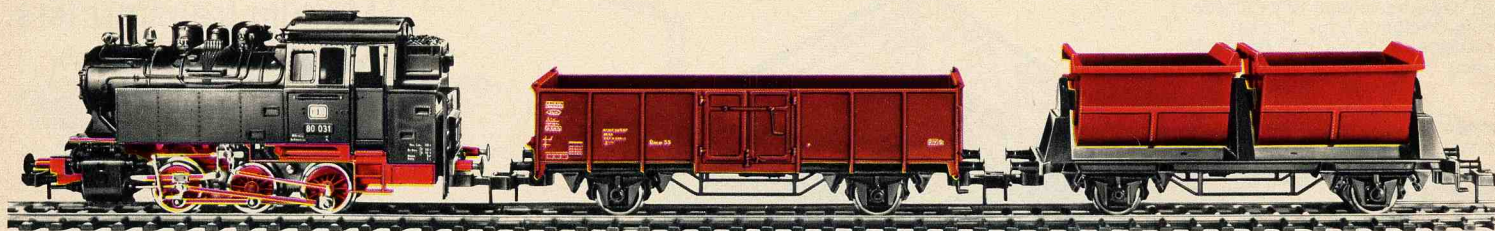

5500

Freight train (without transformer) ·
With tank locomotive 5700, 1 open

freight car 5850, 1 dump car 5859,
2 straight track sections 5900,
12 curved track sections 5921 and
1 feeder connector 5604 · Length of
train 38" (97 cm)

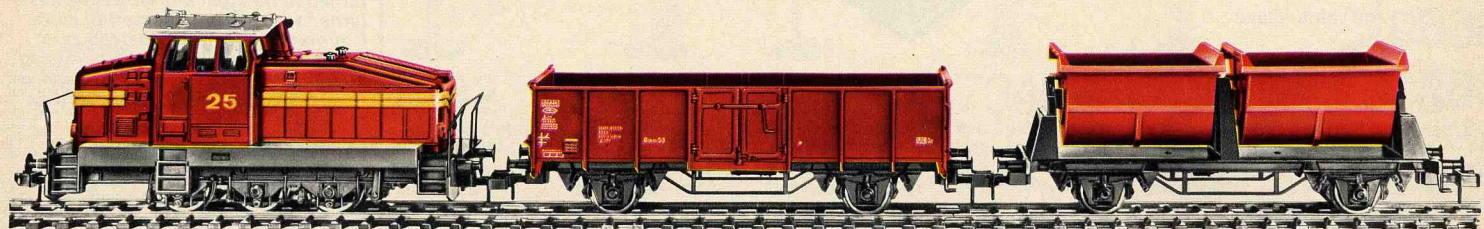

5520

Freight train (without transformer) ·
With diesel locomotive 5720, 1 open

freight car 5850, 1 dump car 5859,
2 straight track sections 5900,
12 curved track sections 5921 and
1 feeder connector 5604 · Length of
train 38" (97 cm)

Tank locomotive

5702

Tank locomotive · 0-6-0 type · 2 rubber
tires · Simulated Heusinger valve gear ·
Remote control for forward and reverse
drive · Three working headlights at
each end · Plastic body, black boiler,
dark green water tank and cab, brass-
colored window frames and hand
rails · Cab doors which open · Windows
with plastic panes · Die-cast zinc
frame · Automatic claw coupling and
sprung buffers at each end · Length
over buffers 12" (30.25 cm)

⊙ = 60015

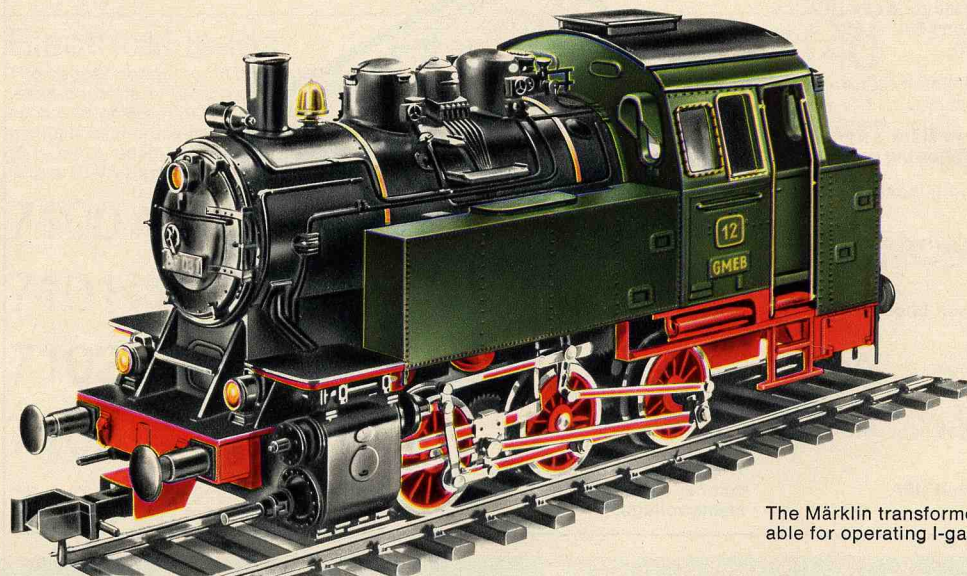

60041

Pair of carbon brushes for I-gauge
locomotive

The Märklin transformer 6631 is suit-
able for operating I-gauge locomotives.

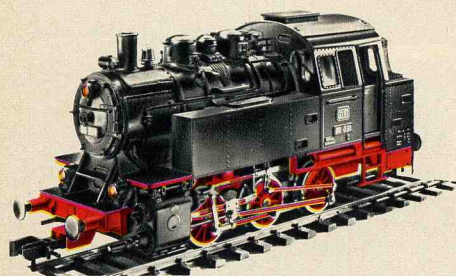

Tank locomotive

5700

Tank locomotive · A model of the
0-6-0 German Federal Railways' Class
80 locomotive · 2 rubber tires · Simu-
lated Heusinger valve gear · Remote
control for forward and reverse drive ·

Three working headlights at each end ·
Mat black plastic body · Cab doors
which open · Windows with plastic
panes · Die-cast zinc frame · Auto-
matic claw coupling and sprung buffers
at each end · Length over buffers 12" (30.25 cm)

⊙ = 60015



Diesel locomotive

5720

Diesel locomotive · A model of a
0-6-0 diesel industrial locomotive ·
2 rubber tires · Remote control for for-
ward and reverse drive · Three working
headlights at each end · Red plastic

body with two yellow horizontal
stripes · Cab doors which open ·
Windows with plastic panes · Die-cast
zinc frame · Automatic claw coupling
and sprung buffers at each end ·
Length over buffers 12" (30.25 cm)

⊙ = 60015

The biggest of the Märklin model railroads -
just as much precision-built as the smallest

5800

Passenger coach · Modelled on a private railroad coach · 2 doors which open · Simulated roof ventilators · Windows inset with plastic frames · Interior fittings simulating wooden seats · Length 12¼" (31 cm)



Passenger coaches with interior fittings

5801

Passenger coach · Modelled on an original of the former Royal Württemberg Railway · Otherwise similar to 5800, in green

Freight cars

5851

Open freight car · A model of the Belgian State Railways' (SNCB) freight car · Length 12¼" (31 cm)

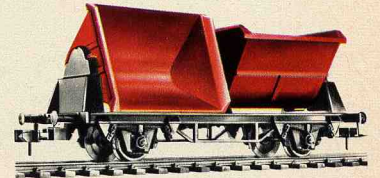
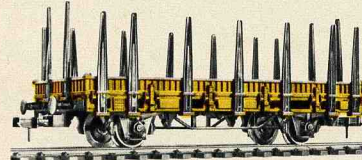

5856

Open freight car · Car body light green · Frame black · Length 12¼" (31 cm)

5850

Open freight car · A model of the German Federal Railways' Omm 55 · Length 12¼" (31 cm)

5853

Flat car · With removable stanchions · Length 12¼" (31 cm)

5859

Dump car · Two independent hoppers dump to either side · Latch holds hoppers in upright position · 12¼" long (31 cm)



5860

Box car · A model of the German Federal Railways' type G1s · Doors which open at each side · Length 12¼" (31 cm)

5861

Beer car · A model of a private car belonging to the Dortmunder Union Brewery · Doors which open on each side · Length 12¼" (31 cm)

5862

Beer car "Staufenbräu" · Doors which open on each side · Length 12¼" (31 cm)

5863

Beer car · A model of a private car owned by the Haller Löwen Brewery · Doors which open on each side · Length 12¼" (31 cm)

5864 new

Beer car · A model of a private car owned by the Kulmbacher Mönchshof Brewery · Doors which open on each side · Length 12¼" (31 cm)



5602

Stop buffer · Riveted steel construction · Sprung buffers · Clips on to the rails · Length 3¾" (98 mm)

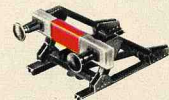

Track sections

The rails, mounted on plastic ties and insulated from one another, not only guide the wheels but also serve as current supply and return conductors for the locomotives. The track sections are connected by the rail links, plus a clip on the plastic tie strip. The rails are made of solid corrosion-resistant sections, so that the track can even be laid in the garden. Outside diameter 4" (1.28 m).

5908

Track section, straight · Length 3" (80.4 mm)



5921

Track section, curved · Radius 24" (600 mm) · Curve 30°



5962

Solenoid-operated left-hand turnout · Operated by double solenoid · Sprung switch points · Crossing angle 30° · Radius of the curved track 24" (600 mm) · Length of straight track 12" (300 mm)

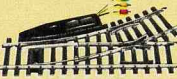

5963

Solenoid-operated right-hand turnout · Operated by double solenoid · Sprung switch points · Crossing angle 30° · Radius of the curved track 24" (600 mm) · Length of straight track 12" (300 mm)



5965

Manual left-hand turnout · Sprung switch points · Crossing angle 30° · Radius of curved track 24" (600 mm) · Length of straight track 12" (300 mm)

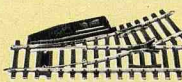

5966

Manual right-hand turnout · Sprung switch points · Crossing angle 30° · Radius of curved track 24" (600 mm) · Length of straight track 12" (300 mm)



5900

Track section, straight · Length 12" (300 mm)



5909

Isolating track section · For isolating the track layout into separate sections electrically · Length 3" (80.4 mm)



5600

Uncoupler · To be installed between the two rails of track section 5900 · Releases the couplings in one direction of travel only, thus permitting kicking of the cars · Length 6½" (175 mm)

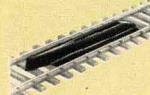

5603

Clips · In packs of 28 · For securing the joints between I-gauge track sections



5604

Power connection fittings · Comprising two connecting terminals with red or brown leads · 3'3" (1 m) long · Incorporating a radio suppressor

Although the two-conductor rail system is used, the introduction of reversing loops, crossings and Y-junction tracks into the layout presents no polarity problem, because we have equipped the large Märklin model railroads, too, with A.C. motors, which means that the advantages of Märklin HO-gauge railroads are also present here. As with the HO-gauge, reversing is effected in the locomotive: here, too, the "engineer" is built in.

There are no problems with direction of travel when you use A.C. current motors



**For racing drivers only one thing matters:
to go faster with Märklin-Sprint
80**

The ideal home automobile racing track

The scale of 1:32 is just right because it means that very little space is needed for the Märklin Sprint racing track. The track is quickly assembled with reliable, rigid mechanical and electrical connections between the track sections, thanks to hinged locking couplings and spring conductor contacts. Although no retaining clips are used, the track will stand up well to prolonged hard racing.

The track can be extended to two, four or six lanes, with long straights or many banked or unbanked curves, inclines, overpasses, lane crossovers, with or without automatic braking sections. Lap counters will indicate the number of laps covered. A comprehensive range of accessories is available to build up the most varied racing circuits, with strong crash barriers for "protection" where necessary.

Every Märklin racing car is a miniature masterpiece. The high-speed motor is favorably located at the center of gravity, providing excellent road holding. Some of the cars have precision stepped gearing attached to the motor which lies lengthwise, giving particularly sensitive response to all voltage variations. It provides short, sharp braking **before** curves and fast acceleration **in** the curves.

Other Sprint cars, those with motors lying transversely, reach very high speeds in the straights, so that they can do very fast lap times, particularly on lengthy layouts with few curves.

Another feature of the superior Märklin quality is the solid, short skid-type pickup with compensating suspension system. This ensures positive contact and reliable and maintained power supply, with the feeder rails and the pickups cleaning themselves at the same time.

The tires of the cars can be changed and adapted to the surface characteristics of the track. The speed controller is designed to provide infinitely variable speed regulation. In the case of 1591 it is also possible to operate at a constant speed by engaging the various steps. In addition, by using the emergency stop-button incorporated, you can develop your own individual driving technique. The speed controller lead can be connected to the track at the point which seems to the "driver" to be tactically most favorable.

A host of valuable hints and tips for designing exciting courses are contained in the interesting Märklin-Sprint Manual. It also covers various "racing rules" for different types of racing on your own track, providing thrilling entertainment for all participants, young and old alike.

Running the small, fast racing cars with the merry, exciting struggle for victory is something quite different from the creative planning which characterises model railroads as a hobby. Because these two hobbies are so basically different from one another, they complement one another for a change.

Gift sets

All Märklin-Sprint sets come in attractive gift sets. Ask your local dealer for the racing track sets with this picture.

Märklin-Sprint automobile racing tracks are fitted with suppressors to meet the regulations and are marked to that effect.

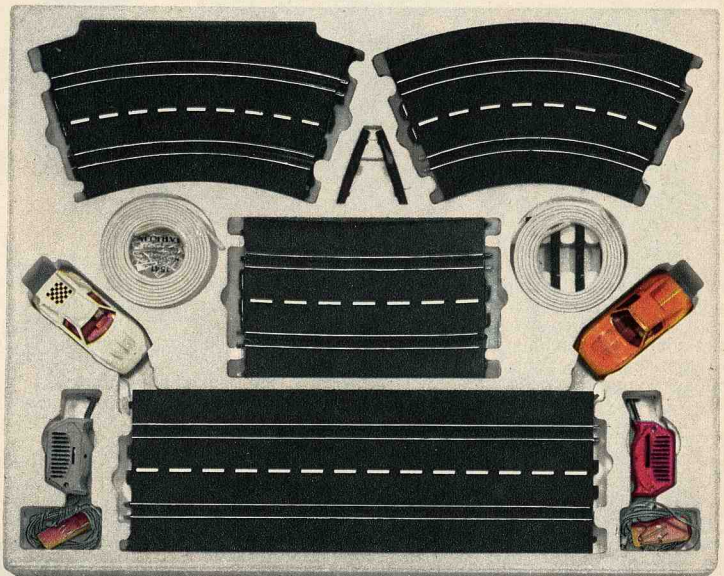

Lap after lap, each one is fighting for the victory

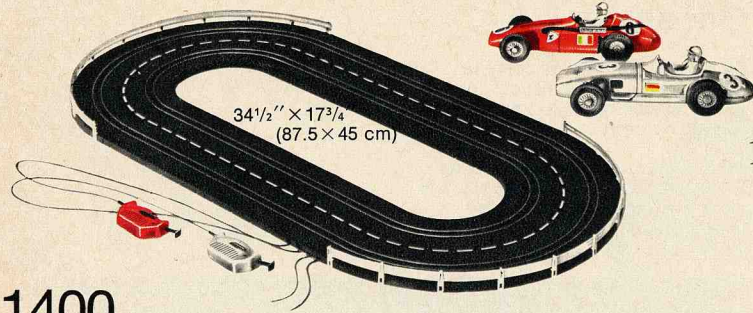

34 1/2'' x 17 3/4''
(87.5 x 45 cm)

1400

34 1/2'' x 17 3/4'' (87.5 x 45 cm)

Racing track set · Comprising two formula racing cars, one Mercedes Monoposto and one Ferrari Super-squalo, two speed controllers, one red and one grey, 4 straight course sec-

tions 1200 and 4 curved course sections 1220, crash barriers and 20 crash barrier supports · These parts will make up an oval circuit · Full instructions are included

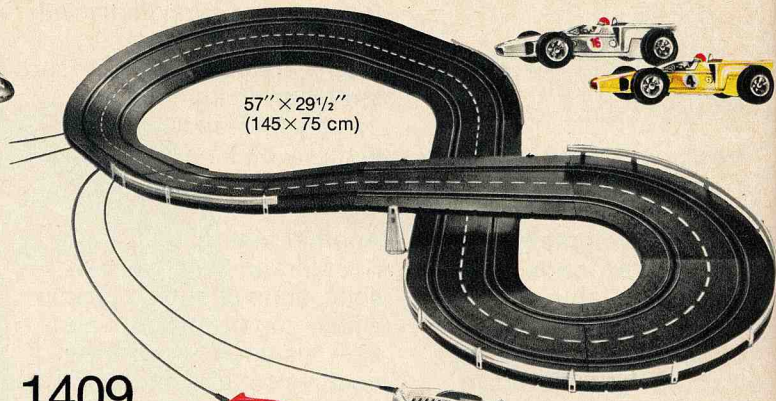

57'' x 29 1/2''
(145 x 75 cm)

1409

57'' x 29 1/2''
(145 x 75 cm)

Racing track set with 1 banked curve · Comprising 2 McNamara racing cars, 1 red and 1 grey speed controller, 2 straight course sections 1200, 2 straight course sections 1201, 2 straight course sections 1206, 3 curved course sections 1220, 2 curved course sections 1241,

4 banked curve sections 1248, crash barriers, 19 crash barrier supports, 3 banked curve supports and 1 fishplate 1547 · These parts enable a figure-eight course with overpass and 1 banked curve to be assembled · Full instructions are included

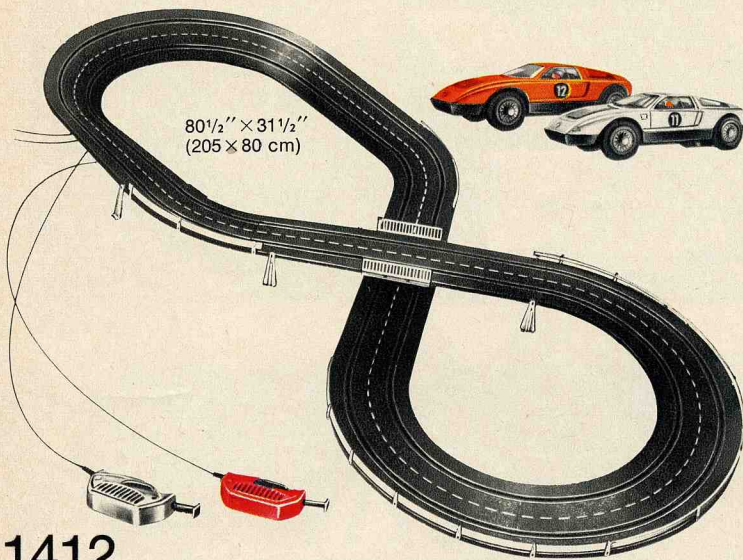

80 1/2'' x 31 1/2''
(205 x 80 cm)

1412

80 1/2'' x 31 1/2'' (205 x 80 cm)

Racing track set with 1 banked curve · Comprising 2 Mercedes C 111 sports cars, 1 red and 1 grey speed controller, 2 straight course sections 1205, 4 straight course sections 1206, 8 curved course sections 1241,

4 banked curve sections 1248, crash barriers, 22 crash barrier supports, 2 bridge parapets, 1 fishplate 1547 and 5 banked curve supports · These parts enable a figure-eight course with overpass and one banked curve to be assembled · Full instructions are included

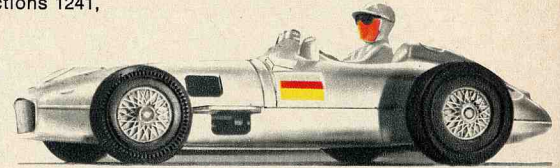

1300

Formula racing car · A model of the Mercedes W 196 Monoposto · Driven through multi-ratio gearbox · Silver-colored plastic body · 5'' (12.8 cm) long · Spare tires for this car: front 1500, rear 1501 or 1504



1301

Formula racing car · A model of the Ferrari Supersqualo · Driven through multi-ratio gearbox · Red plastic body · 5'' (12.5 cm) long · Spare tires for this car: front 1500, rear 1501 or 1504

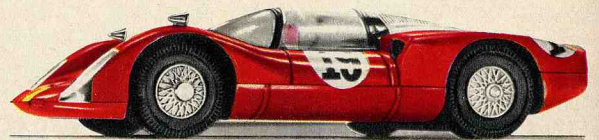

1305

Sports car · A model of the Porsche Carrera 6 · Driven through multi-ratio gearbox · Red plastic body · Cockpit enclosed by clear plastic hood · 5 1/8'' (13 cm) long · Spare tires for this car: front 1500, rear 1503

1405

96 3/8'' x 39 3/8'' (245 x 100 cm)

Racing track set with 1 banked curve · Comprising 1 white and 1 orange-colored Mercedes C 111, 1 red and 1 grey speed controller, 2 straight course sections 1200, 4 straight course sections 1201, 2 straight sections 1205, 8 curved course sections 1241, 4 banked curve sections 1248, 2 banking approach course sections 1290, 2 levelling out sections for end of banking 1291, crash barriers, 30 crash barrier supports, 4 fishplates 1547 and 2 clips · With these parts a figure-eight course with an overpass and one banked curve can be constructed · Full instructions are included

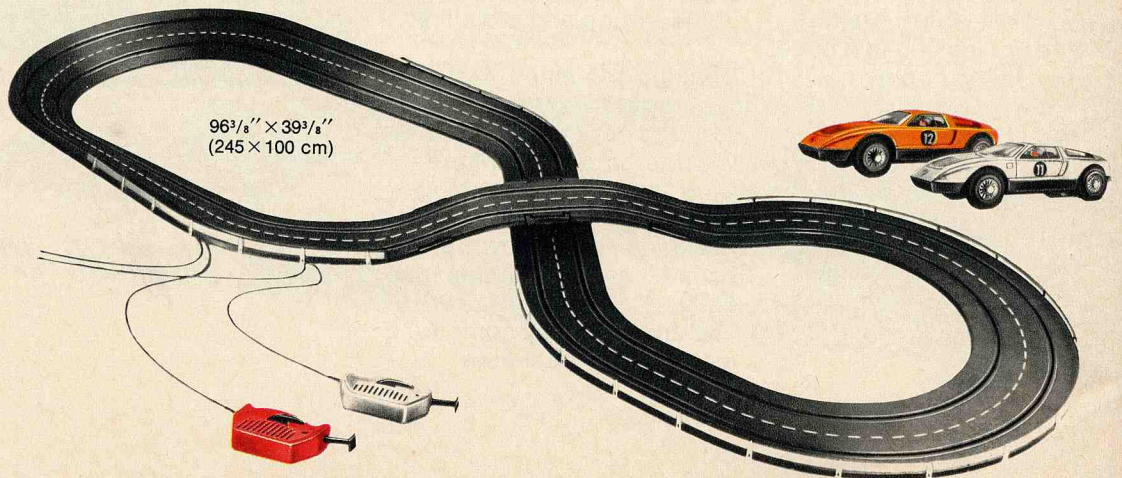

96 3/8'' x 39 3/8''
(245 x 100 cm)

On any track the drive feels the urge to achieve the best time

Racing and sports car 1:32

Märklin
Sprint

The front wheels are steered by slots in the course. Accurate reproduction of the suspension arm assembly. Current pickup by 2 sprung skids.



1308

Sports car · A model of the Jaguar E-type · Swing front axle · Driven through spur gears · Red plastic body · Inset windows · 5 1/4" (13.4 cm) long · Spare tires for this car: front 1500, rear 1503



1310

Sports car · A model of the Porsche 911 T Targa · Swing front axle · Driven through spur gears · Orange plastic body · Inset windows · 5" (12.9 cm) long · Spare tires for this car: front 1500, rear 1503

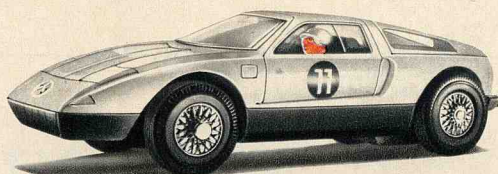

1311

Sports car · A model of the Mercedes C 111 · Swing front axle · Driven through spur gears · White body · Black chassis · Inset windows · 4 3/4" (12 cm) long · Spare tires for this car: front 1500, rear 1503



1312

Sports car · Construction as for 1311, but orange body

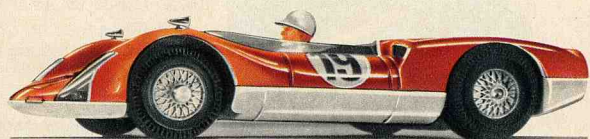

1314

Sports car · Construction as for 1305 but with open cockpit with windshield · Orange body · White chassis · 5 1/8" (13 cm) long



1315

Sports car · A model of the Chaparral 2 E with rear stabilising fin · Driven through multi-ratio gearbox · Silver-colored plastic body · 2 working headlights · Cockpit enclosed by clear plastic hood · 5 1/8" (13 cm) long · Spare tires for this car: front 1500, rear 1503

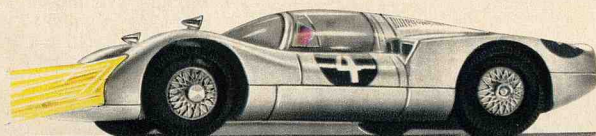

1316

Sports car · A model of the Porsche Carrera 6 · Driven through multi-ratio gearbox · Silver-colored plastic body · 2 working headlights · Cockpit enclosed by clear plastic hood · 5 1/8" (13 cm) long · Spare tires for this car: front 1500, rear 1503

Q = 60000

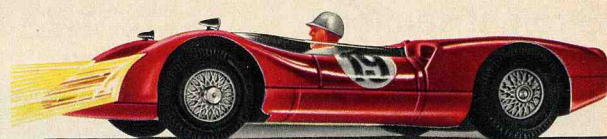

1317

Sports car · Construction as for 1316 but with open cockpit with windshield · Red plastic body · 5 1/8" (13 cm) long

Q = 60000

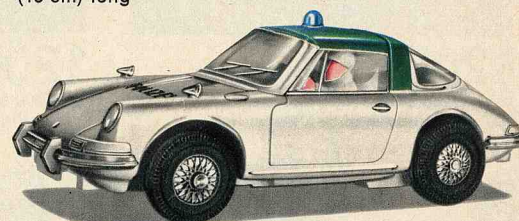

1318

Sports car · Porsche 911 T Targa as police car · Continuously operating flashing blue light controlled by diodes · Swing front axle · Driven through spur gears · Green and white plastic body · Inset windows · 5" (12.9 cm) long · Spare tires for this car: front 1500, rear 1503

Q = 60209



1319

Racing car · A model of the McNamara · Driven through spur gears · Yellow plastic body · 4 7/8" (12.3 cm) long · Spare tires for this car: 1505



1320

Racing car · A model of the Lola T 222 · Driven through spur gears · Plastic body · 5" (12.7 cm) long · Spare tires for this car: 1505

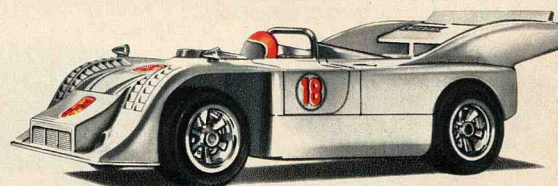

1321

Sports car · A model of the Porsche Can Am 917/10 · Driven through spur gears · White plastic body · Open cockpit with windshield · 5 1/4" (13.4 cm) long · Spare tires for this car: 1505



new

1322

Sports car · Model of the BMW 2002 turbo · Driven through spur gears · Plastic body · 5" (12.6 cm) long · Spare tires for this car: 1505



new

1323

Sports car · Construction as for 1322 but in other colors

**Centrally located engines, multi-ratio gear boxes, transverse engines...
...every fast car demands its own special driving technique**

Straight sections

Two lanes · With feeder connection to 1200, 1201, 1205 and 1206

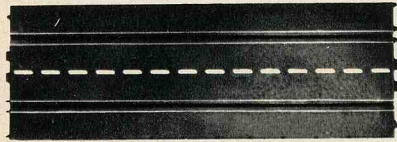

1205

16 3/4" (424.2 mm) long
(twice the length of 1200)

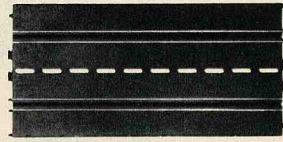

1206

12" (300 mm) long
(twice the length of 1201)

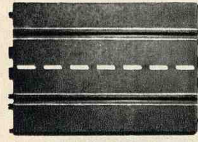

1200

8 3/8" long
(212.1 mm)

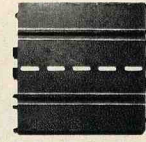

1201

6" long
(150 mm)

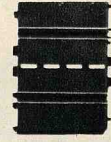

1202

4 3/16" long
(106 mm)



1203

2 7/16" long
(62.1 mm)



1204

1 3/4" long
(44 mm)

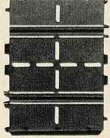

1207

Controlled zone set · Comprising 2 sections each 4 1/8" (106 mm) long · For use at approach to chicane or lane-change sections · The first vehicle

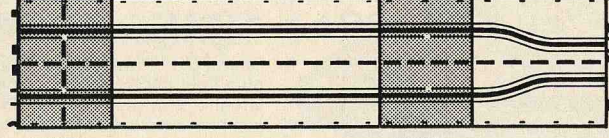

1207

1207

entering this section automatically shuts off the power to the other lane and restores it only after leaving the controlled zone

All course sections are made of rigid plastic with slots for guiding the cars, current being supplied to the cars by contact rail arranged on both sides of the slots. Snap-on link couples the sections of track together. No additional braces are required. The sections are black with a broken white line in the center.

Chicane, straight section

1216

Chicane, straight section · Two lanes · Track spacing reduced from 3" (75 mm) to 1 1/2" (38 mm) · 6" (150 mm) long · 2 such track sections are necessary

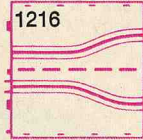
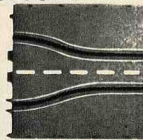

1216

Change lane section, straight

Change lane sections (1217, 1227) cannot be used singly. They must either be used in pairs or in combination with one another.

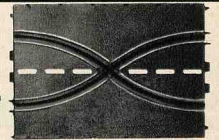

1217

8 3/8" (212.1 mm) long · Two lanes · The crossing conductor rails are electrically insulated from one another

Change lane section, curved

The crossing conductor rails are electrically insulated from one another.



1227

90° curved change lane section · Two lanes · Mean radius 6" (150 mm)

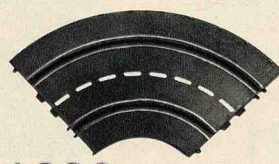

1220

90° curved course section · Two lanes · Mean radius 6" (150 mm)

Curved course sections

With feeder connections to 1220, 1241 and 1261

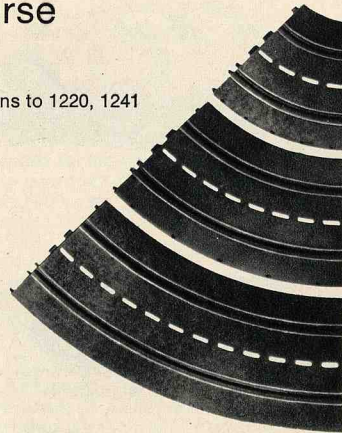

1221

45° curved course section · Two lanes · Mean radius 6" (150 mm)

1241

45° curved course section · Two lanes · Mean radius 12" (300 mm)

1261

45° curved course section · Two lanes · Mean radius 18" (450 mm)

45° banked curved course sections

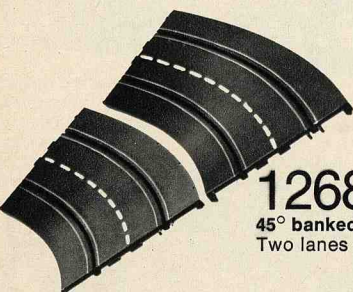

1248

45° banked curved course section · Two lanes · Mean radius 12" (300 mm)

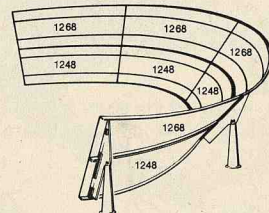

1268

45° banked curved course section · Two lanes · Mean radius 18" (450 mm)

1546

Set of banked curve supports · Comprising 7 cross supports, 3 columns 5" (128 mm) high, 4 columns 3" (78 mm) high and 12 connectors · Made of plastic · Required for 4-lane banked curves

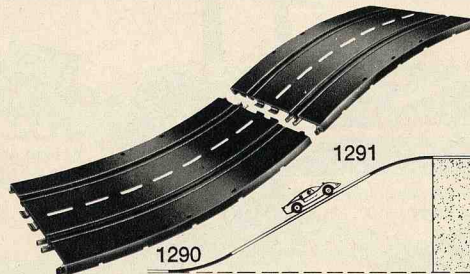

1290

1291

Inclines

1290

Straight levelling-out section for start of incline · Two lanes · Concave pattern · Beginning and end of track form an angle of about 30° · 8 5/8" (220 mm) long

1291

Straight levelling-out section for end of incline · Similar to 1290 but convex pattern · Including 1 bracket for stiffening the section

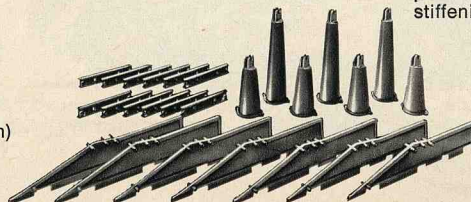

Absolutely everything you need for the most exciting races on your own racing track



6771 **new**
Märklin-Sprint power supply unit · For use on 220 Volt AC · Output 14 Volts DC approximately · Power output 10 watts · Overload protection by automatic current limiter · Plastic case · Weight 2½ lbs. (1.2 kg) · Dimensions 5" × 5¼" × 2⅛" (125 × 135 × 55 mm)

The use of power supply unit 6771 is recommended. If Märklin railroad transformers are used, it is essential to connect the rectifier 1592 between the transformer and the speed controller.

Important!
Märklin-Sprint racing cars must only be operated with DC supply.



1592
Rectifier · For use in conjunction with Märklin railroad transformers · Dimensions 2¼" × 2" × ⅜" (57 × 52 × 15 mm) · DC supply for operating up to 4 cars simultaneously, can be taken from the 2 pairs of sockets marked "Auto 1" and "Auto 2" · The transformer to be used must be rated 16 VA or more



1593
Starting clock · To be connected between the power supply unit and the racing track layout · Interrupts the power supply to the racing track layout when the set time, which is adjustable between 0 and 5 minutes by means of a knob, has elapsed · The "off" is given by pressing the red "start" button



1545
Mechanical lap counter · Mounted on a two-lane section 4⅞" (106 mm) long · Displays up to 99 laps for each lane in either direction · Can be zeroed by hand · 5" (130 mm) high · 6" (150 mm) wide · **A section 1202 is required as a make up length** · On multi-lane courses, several lap counters can be arranged in line, side by side

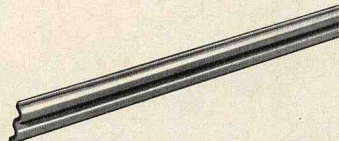

1540
Crash barrier · Flexible corrugated plastic section · White · 6'7" (2 m) long

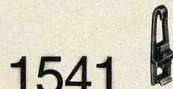

1541
Support for crash barrier · Made of white plastic · For fixing crash barriers to the course

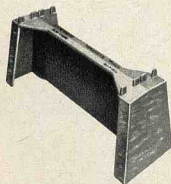

1543
Pier · 2⅛" (61.5 mm) high · Made of grey plastic · Mounting stubs on top engage in course sections



1591
Speed controller with connecting fittings · Red · Shaped to be easy to handle · Control key will engage at various speeds · An emergency stop-button enables the power to be disconnected without losing the control key setting · Built-in suppressor condenser · The fittings comprise connector plate with a 2-core lead, 4'9" (1.5 m) long, to the speed controller and another 2-core lead, 3'3" (1 m) long, with plug for connecting to the power supply unit · A speed controller must never be used to control more than one car at a time



1594
Speed controller with connecting fittings · Large version · 40 Ohms · Electrodynamic brake effective with press key in position of rest · Built-in suppressor condenser · The fittings comprise the connecting plate with a 3-core lead to the speed controller and a 2-core lead with plugs for connecting to the power supply unit · A speed controller must never be used to control more than one car at a time

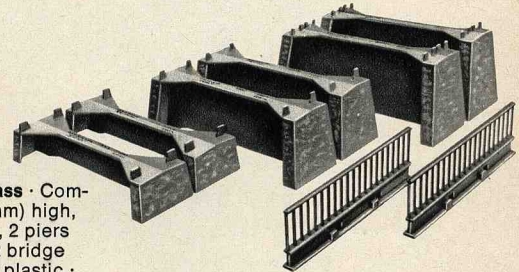

1542
Construction kit for overpass · Comprising 2 piers, 1¼" (27 mm) high, 2 piers 1⅞" (49 mm) high, 2 piers 2⅝" (61.5 mm) high, and 2 bridge parapets · All parts in grey plastic · Enables a very solid overpass to be built spanning even multi-lane courses

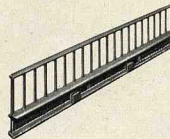

1544
Bridge parapet · For reinforcing overpasses · Made of grey plastic · 5⅞" (135 mm) long · 1½" (38 mm) high



1547
Fishplate · 2⅞" (74 mm) long · Made of black plastic · For connecting two adjoining straight sections and reinforcing the joints

Tire sets

1500
 Comprising 2 rubber tires 20.5 mm diam × 6 mm · For models 1300, 1301, 1305, 1308, 1310, 1311, 1312, 1314, 1315, 1316, 1317, 1318

1501
 Comprising 2 rubber tires 23 mm diam × 7 mm · For models 1300 and 1301

1503
 Comprising 2 rubber tires 20.5 mm diam × 7.6 mm · For models 1305, 1308, 1310, 1311, 1312, 1314, 1315, 1316, 1317, 1318

1504
 Comprising 2 rubber tires 24 mm diam × 8.4 mm · For models 1300, 1301

1505
 Comprising 2 rubber tires 20.5 mm diam × 8.5 mm · For models 1319, 1320, 1321, 1322, 1323

Adaptation pickup skids

1510
 (1 pair) · Mount-on pickup skids for Märklin-Sprint cars to adapt them for tracks of other makes

Motor brushes

60146
 For Märklin-Sprint car motors



0751
Märklin-Sprint Racing Track Manual with suggestions for designing race tracks · Includes rules for racing and interesting illustrations · 44 pages · Format 7" × 11" (18 × 28 cm) · English text

Märklin miniature automobiles made of die-cast zinc with moving parts and special wheel fittings

These models are precision-engineered down to the last detail. The doors, hoods and trunk lids, etc. will open, the windows are glazed. Full interior fittings. "rak" models have a special finish to ensure particularly smooth running. "rak"—that is Real Automobile Knack.

Ask your dealer for the special prospectus giving the complete range of Märklin "rak" miniature automobiles.

1975 Range

- 1800 Porsche 911 T Targa
- 1802 Chaparral 2 F
- 1804 BMW 2800 CS
- 1805 VW-Variant 1600
- 1807 VW-Variant 1600—fire engine
- 1808 VW-Variant 1600—road assistance
- 1809 VW-Variant 1600—ambulance
- 1810 Porsche 910
- 1812 BMW 1600 GT
- 1813 Mercedes C 111
- 1814 BMW 3000
- 1817 Mercedes 250
- 1818 Chevrolet Corvette
- 1819 BMW 2002 ti
- 1821 Audi 100 LS
- 1822 Ford Capri 2300

- 1823 VW-Variant 1600—police
- 1824 Caravan
- 1825 VW 411
- 1826 VW-Porsche 914
- 1828 Mercedes 250—police
- 1829 Mercedes 250—taxi
- 1830 Unimog platform
- 1831 Unimog platform with accessories, 6 parts
- 1834 Audi 100 Coupé
- 1835 Opel Manta
- 1837 VW K 70
- 1839 Mercedes 350 SL



They have everything on them, everything in them, correct to the last millimetre - Märklin rak cars have the real automobile knack.

Can now be combined* with the new Märklin plus** construction kit system

* (see page 88)

** (see pages 90–97)

Märklin metal construction sets — prepare for the future while playing

The technology of the future will determine the quality of life to such an extent that it is as well for the young to prepare themselves for it early. Märklin metal construction sets provide a good way of learning about technical things while playing.

Their recognised advantages reside, on the one hand in the educationally well-thought-out system of five basic sets, each intended for a particular age group, and, on the other hand, in having the right parts accurately reproducing those used in practice and assembled with real bolts, again as in practice.

This grading by age and the technical realism are very important factors. They mean that a child as young as five, while playing, becomes aware of the very simple relationships and can continue and increase his knowledge until he has a clear conception of the laws of mechanics and (from set 1013 on) of electricity, and this is always with due regard to his age and as his set is being extended with the supplementary sets.

A Märklin metal construction set not only arouses enthusiasm because of its unlimited possibilities and realistic components, but it is also of real assistance in providing practical knowledge.

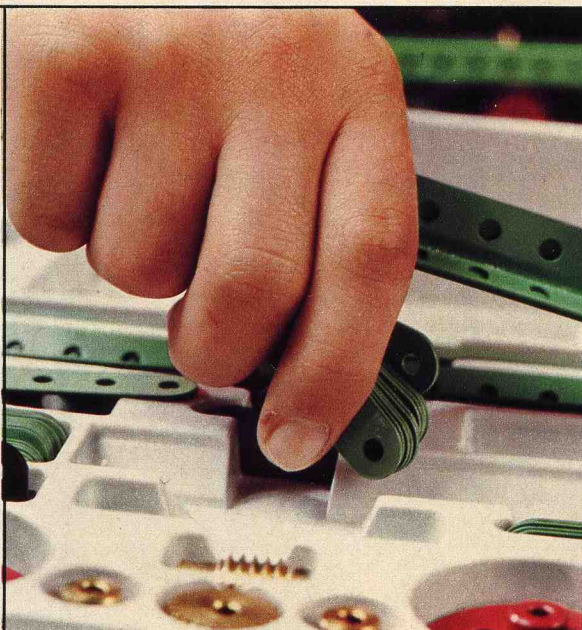

You build it yourself — putting components together one after the other

Märklin metal construction sets with real bolt assembly

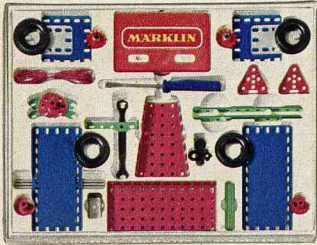

1010

Basic set for children from 5 years upwards · Comprising 176 constructional parts · Size 16" × 12" × 1 1/4" (40.6 × 30.6 × 3.2 cm) · Weight 2 lbs. 5 oz. (1.050 kg) · The instruction book even with this smallest set shows more than 90 models which can be built, including small trucks, windmills, cranes, etc. In the process it teaches what pulley blocks, gear ratios and couplings are · Can be built up to Basic Set 1011 by adding Supplementary Set 1030

1011

Basic set for children from 6 years upwards · Comprising 242 constructional parts · Size 20 1/4" × 13 3/4" × 1 1/4" (52 × 35 × 3 cm) · Weight 3 lbs. 14 oz. (1.750 kg) · All sorts of mechanical models can be built with this set, the range extending from scooter to logging truck, from weighing machine to cable car, from excavator to mobile crane, with everything true to the originals and fully working · Can be built up to Basic Set 1012 by adding Supplementary Set 1031



1012

Basic set for children from 7 years upwards · Comprising 396 constructional parts · Size 20 1/4" × 13 3/4" × 1 1/2" (52 × 35 × 3.6 cm) · Weight 6 lbs. 13 oz. (3 kg) · Set 1012 enables still more detailed models to be built, such as diesel locomotives, large trucks, tower cranes, windmills, drilling rigs, etc. · A good appreciation of the laws of mechanics achieved · Can be built up to Basic Set 1013 by adding Supplementary Set 1032

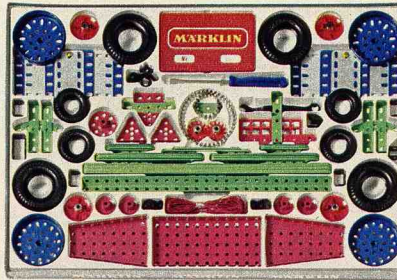

1013

Basic set for children from 10 years upwards · Comprising 703 constructional parts · Size 20 3/4" × 14 1/4" × 2 5/8" (53 × 37 × 7 cm) · Weight 11 lbs. 11 oz. (5.3 kg) · From this set onwards, electrical components are included, such as commutator, solenoid, electrical leads, etc. · A short "Course in Electricity" gives an introduction to the principles of electricity and electromagnetism and many models enable this knowledge to be applied · Can be built up to Basic Set 1014 by adding Supplementary Set 1033

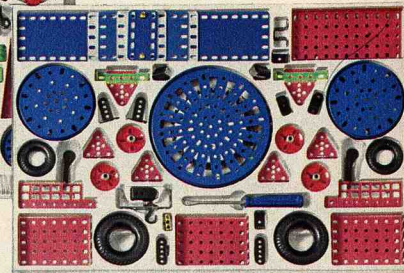
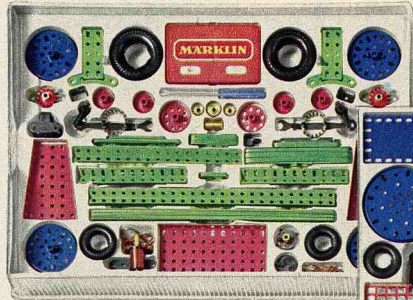

1014

Basic set for children from 10 years upwards · Comprising 1006 constructional parts · Size 25 1/4" × 16 5/8" × 2 5/8" (64.5 × 41.5 × 6.4 cm) · Weight 16 lbs. 4 oz. (7.2 kg) · The contents of this set are for enthusiasts young and old alike · The capabilities at this stage include impressive models built up out of hundreds of separate parts · It is also possible to make mechanical and physical models based strictly on scientific principles · Can be extended one stage further by adding Supplementary Set 1034

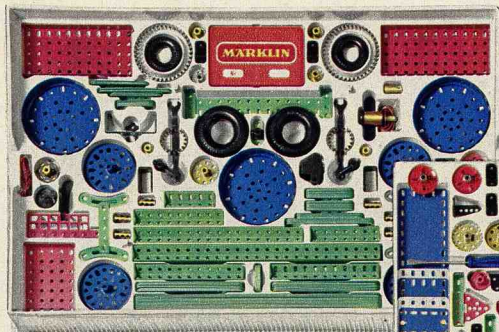

9330

Connecting block set · Contains 6 different sorts of building blocks which offer a variety of interesting ways of combining Märklin metal construction sets and Märklin plus

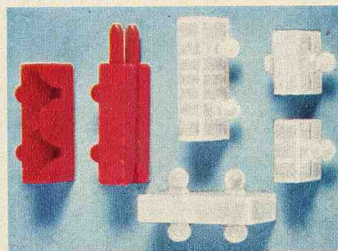

Example of combination of Märklin construction sets and Märklin plus (see also Page 97)

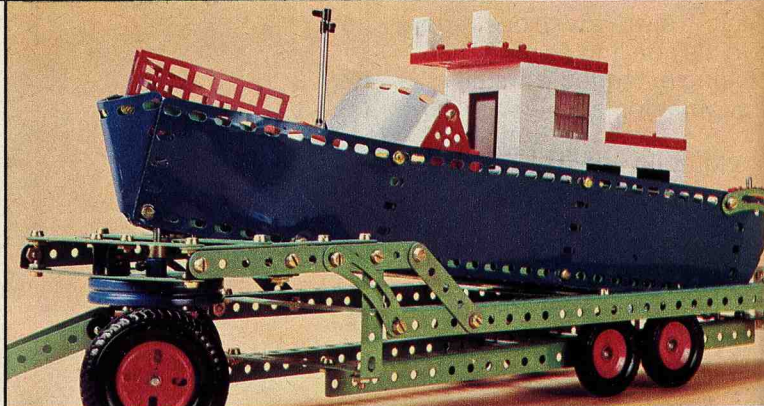

Work with screwdriver and wrench,
build out of steel and brass

Any basic set can be built up to the next larger one by adding a supplementary set, whose contents added to the existing basic set make up the new larger basic set. If, for example, you have Basic Set 1010 and would like to bring it up to Basic Set 1011, then you would require Supplementary Set 1030.

Apart from the supplementary sets mentioned above, any Märklin metal construction set can be extended by individual parts if your set does not have enough parts for a particular model you wish to make, or by special parts which are not included in your set. A special list of these parts, as well as the parts themselves, can be obtained from any toy shop which stocks Märklin products.

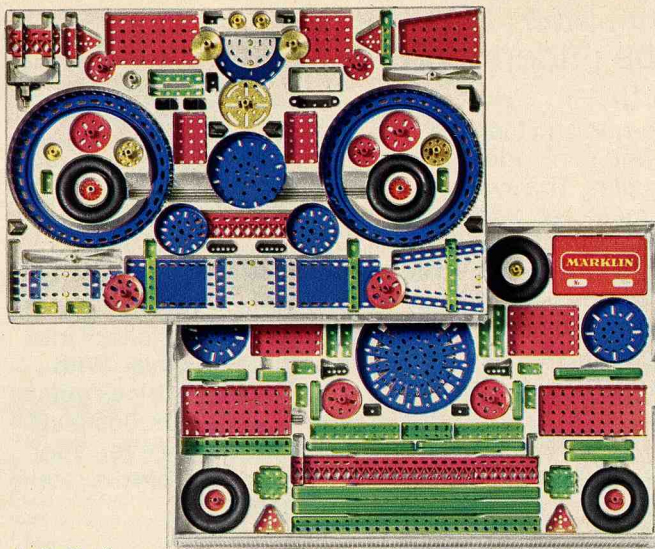

1034

Supplementary Set extends Basic Set 1014 a stage further

Number of constructional parts in the Märklin metal constructional sets

Basic Set No.	Number of parts	Supplementary Set No.	Number of parts
1010	176	1030	67
1011	242	1031	164
1012	396	1032	308
1013	703	1033	307
1014	1006	1034	1100

In brief:

Supplementary Set **1030** converts Basic Set 1010 into Basic Set 1011

Supplementary Set **1031** converts Basic Set 1011 into Basic Set 1012

Supplementary Set **1032** converts Basic Set 1012 into Basic Set 1013

Supplementary Set **1033** converts Basic Set 1013 into Basic Set 1014

Individual Parts Sets

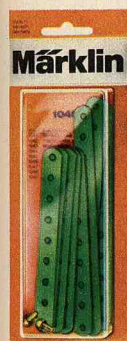

1040
Individual Parts Set · Comprising flat strips, bolts and nuts



1041
Individual Parts Set · Comprising connecting pieces such as bearing yoke, double angle, angle piece, guide fork and flat piece



1042
Individual Parts Set · Comprising flat strips, connecting and bearing bracket

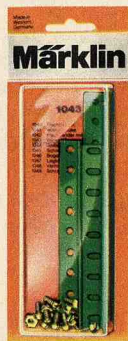

1043
Individual Parts Set · Comprising angle supports, bolts and nuts



1044
Individual Parts Set · Comprising shafts of various lengths, setting rings and hand crank

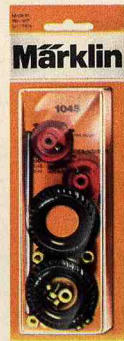

1045
Individual Parts Set · Comprising cord pulley, rubber tires, shaft and setting rings



1046
Individual Parts Set · Comprising curved strips, bolts and nuts



1047
Individual Parts Set · Comprising bearing plates, bolts and nuts



1048
Individual Parts Set · Comprising bearing brackets, supporting brackets, branch connections and connecting pieces



1049
Individual Parts Set · Comprising long and short bolts with nuts

Electric motors for driving models

It is a particular pleasure to any youngster to construct models in accordance with the Instruction Book or his own ideas and to see them work "automatically". The two electric motors illustrated can be used to power models in this way, including those assembled from the smallest basic set.

1071

Electric motor · Reversible to run in either direction · No-load speed 1500 rpm approx. · Runs on 16 Volts, so it can be connected to Märklin HO-gauge railroad transformer · Accessories: 2 leads · 2 1/2" (6.5 cm) high · 2" (5 cm) wide · 2" (5 cm) long · Weight 7 oz. (200 g)

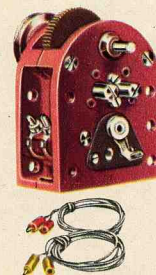

1072 ELEX

ELEX Electric motor · 16 Volt · With lead and reversing switch · Two cord pulleys running in opposite directions at different speeds which are variable by the transformers · No-load speed 3000 and 1100 rpm approx. · Extremely powerful motor suitable for driving the largest models made up from the construction sets, as well as working models of all types · 3 connecting plugs · 2 1/2" (6.5 cm) high · 3 3/4" (9.5 cm) long · 2 1/2" (6.5 cm) wide · Distance between pulley grooves 3 1/2" (8.9 cm) · Weight 23 1/2 oz. (670 g)

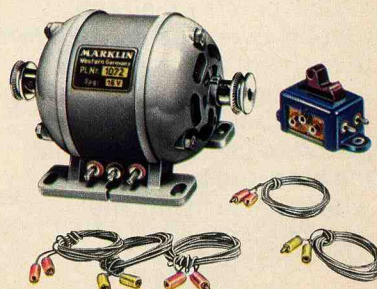

Machines with rollers, wheels, gears, set into motion by robust motors

Märklin plus
the new play-build
system for children
growing up

Can now be
combined* with
Märklin metal
construction sets**
with the real bolt
assembly system

* (see page 97)

** (see pages 87-89)

Summary of the system

A Basic sets with basic
and wall building
blocks for solid
structures

AB
+ B Basic sets with basic
building blocks,
narrow blocks and
bearing blocks for
mechanical models

BE Extension kits for B

C Construction sets for
single models

E Sets of individual
parts

F Electromechanical
functional parts

G Large building blocks
for the toddlers

Märklin plus Is good at everything

This new construction kit
system caters for all age
groups. Everyone can build
to his heart's content, as
talent and imagination dic-
tate. No building block ever
becomes useless. The build-
ing block the toddler builds
with will also fit into the
enthusiast's model.

Märklin plus Can be understood in no time

Anyone who can fasten a
press-stud can understand
Märklin plus. The system
can be mastered without any
effort. Märklin plus will de-
velop into an essential com-
panion for the years of play
and hobby and become an
aid to learning and a career.

Märklin plus The system with no limits

Extending by steps, Märklin
plus open up even the field
of electromechanics. What
is especially pleasing in that
this well-thought-out system
can be purposefully and
economically utilised. None
of the building blocks is
unnecessary.

Märklin plus The ideal aid to teaching and learning

Märklin plus promotes logic,
awakens hidden talents
and stimulates the imagi-
nation. The joy of having
created something meaning-
ful with one's own hands
provides an important motive
in the years of learning.
Märklin plus is more than
a pastime.

Märklin plus The "fast" system

"Quickly assembled, equally
quickly dismantled" is the
motto of Märklin plus. Chil-
dren derive particular pleas-
ure in showing you, after a
short time, what they have
been able to make.

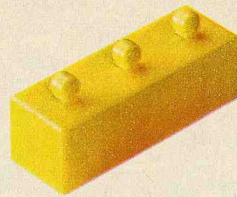

The basic building block

engages with a "click" into
the adjoining block. With
Märklin plus no block gets
worn out. Continuous tests
have shown that even after
long use these blocks retain
their solidity.

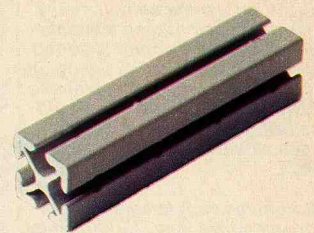

Märklin plus flexible-sided narrow building block

This flexible-sided narrow
building block is available in
lengths up to 7 7/8" (20 cm),
and have guide slots in all
their four faces.

Other building blocks can
simply be pressed into their
flexible sides.

This is one of the great
advantages of Märklin plus:
it enables extensions of the
greatest variety to be built
on to an existing structure,
without modifying the
original structure.

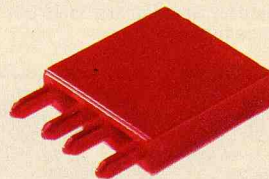

Wall building blocks

are another basic elements
in the system without limits.
With them flat roofs, gabled
roofs, floors including inter-
mediate floors, and much
else, can be built.



Connectors and struts

provide stability exactly as
in the real-life structures
which serve as models. You
can safely use your strength
with Märklin plus. All the
parts will stand a lot of use,
are robust and will not
wear out.

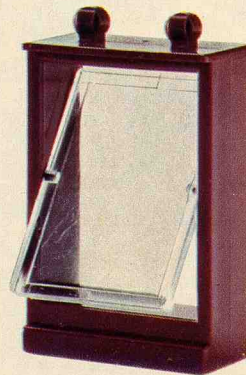

Windows and doors

are made with careful
attention to detail. Windows,
doors and garage doors
are made to open, close,
swing and pivot and windows
with sliding roller blinds.
The children will be so keen.



A 9000

Basic set · Comprising basic and wall building blocks of various sizes and colors, and also door, windows and a base plate for building simple structures and small houses with flat roofs · Instructions are included

Model built from 9000

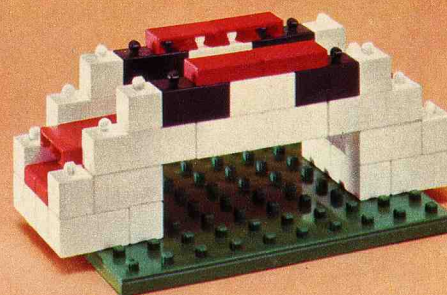

A 9001

Basic set · Comprising basic and wall building blocks of various sizes and colors, and also door, windows and a base plate for building small houses with flat and sloping roofs · Instructions are included

Model built from 9001

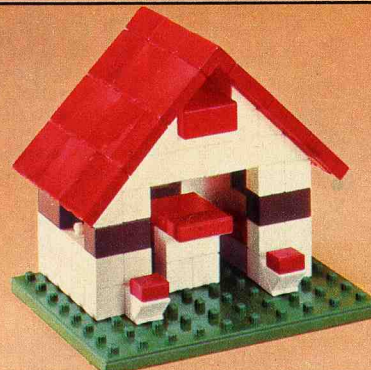

A 9002

Basic set · Comprising basic and wall building blocks of various sizes and colors, and also door, windows, sets of wheels and base plates for building houses and vehicles · Instructions are included

Model built from 9002

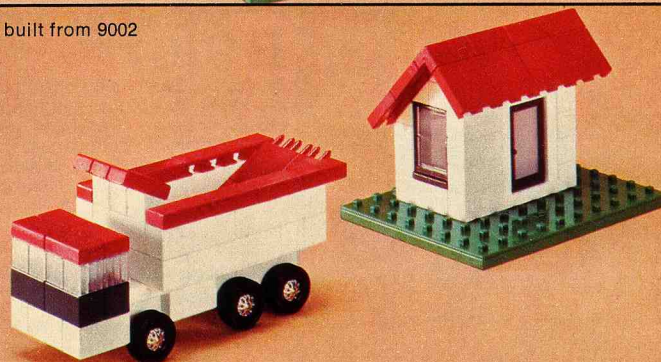

A 9003

Basic set · Comprising basic, wall and corner building blocks of various sizes and colors, and also doors, windows, sets of wheels and base plates for constructing all kinds of buildings and vehicles · Instructions are included

Model built from 9003

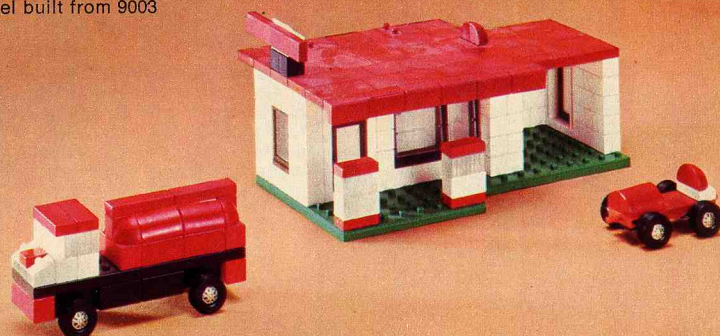

A 9004

Basic set · Comprising a wide selection of basic, wall and corner building blocks of various sizes and colors, and also doors, gateway, windows, sets of wheels and base plates for constructing buildings, garages and vehicles · Instructions are included

Model built from 9004

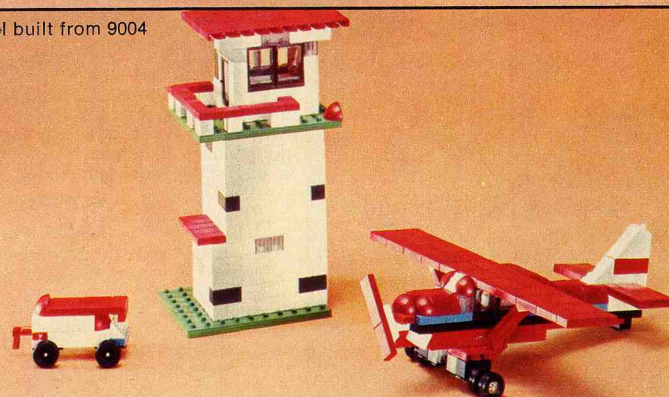

Components made of an indestructible material



AB 9500

Basic set · Comprising a rich assortment of a wide variety of building and bearing blocks and also narrow building blocks, shafts, wheels, door and windows for constructing buildings and mechanical models · An instruction book is included

Model built from 9500

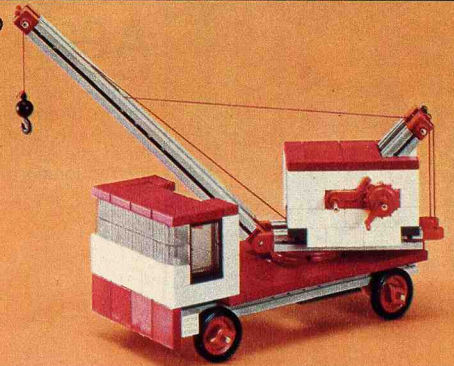

B 9100

Basic set · Comprising basic building blocks, narrow blocks and bearing blocks, and also wheels, for constructing simple mechanical models such as cranes and machines · An instruction book is included

Model built from 9100

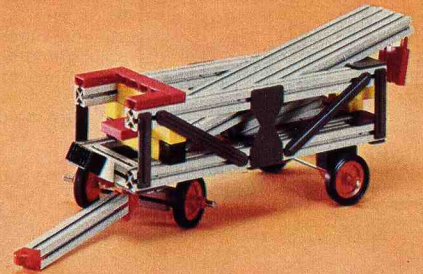

B 9101

Basic set · Comprising basic building blocks, narrow blocks and bearing blocks, and also wheels and gear wheels for constructing mechanical models with gear drives · An instruction book is included

Model built from 9101



B 9102

Basic set · Comprising basic building blocks, narrow blocks and bearing blocks, struts, wheels, and gear wheels for constructing a wide variety of mechanical models and vehicles of higher complexity · An instruction book is included

Model built from 9102



B 9103

Basic set · Comprising a large number of components of all sorts, including a drive motor, for constructing engineering models with scientific exactitude · An instruction book is included

Model built from 9103

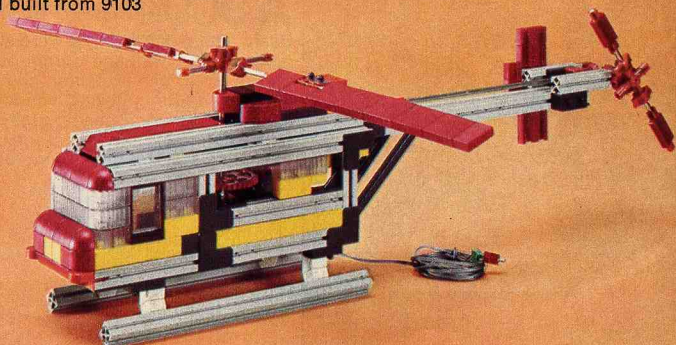

Build, test, modify, improve, until you arrive finally at a fully developed piece of engineering

The economical system

The basic sets in the B series can be sensibly enlarged using the BE extension kits.

Extension kit **9150**
converts Basic Set 9100 into 9101

Extension kit **9151**
converts Basic Set 9101 into 9102

Extension kit **9152**
converts Basic Set 9102 into 9103



BE 9150
Extension kit with instruction book ·
Converts set 9100 into 9101

BE 9151
Extension kit with instruction book ·
Converts set 9101 into 9102

BE 9152
Extension kit with instruction book ·
Converts set 9102 into 9103

Sets of individual parts

The E series contains a rich assortment of individual parts sets for a wide variety of uses. This assortment leaves nothing to be desired.

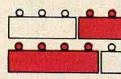
E 9300 
Set of building blocks, white and red

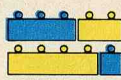
E 9301 
Set of building blocks, blue and yellow

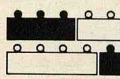
E 9302 
Set of building blocks, black and transparent

E 9303 
Set of half-size building blocks, white and red

E 9304 
Set of half-size building blocks, blue and yellow

E 9305 
Set of half-size building blocks, black and transparent

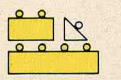
E 9306 
Set of building blocks for sloping roof, white and yellow

E 9307 
Set of building blocks for sloping roof, white

E 9308 
Set of door and window building blocks

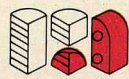
E 9309 
Set of round corner building blocks, white and red

E 9310 
Set of round corner building blocks, blue and transparent

E 9311 
Set of wall building blocks, red

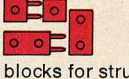
E 9312 
Set of wall building blocks for structures on roofs

E 9313 
Set of coping blocks

E 9314 
Set of various bearing blocks

E 9315 
Set of short narrow building blocks

E 9316 
Set of narrow building blocks, 1" (25 mm) and 4" (100 mm) long approx.

E 9317 
Set of narrow building blocks, 2" (50 mm) and 8" (200 mm) long approx.

E 9318 
Set of flat connectors

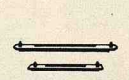
E 9319 
Set of struts, short

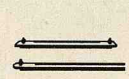
E 9320 
Set of struts, long

E 9321 
Set of gear wheels with racks and worm gear

E 9322 
Set of gear wheels and worm gear

E 9323 
Set of shafts with ball joint

E 9324 
Set of cord pulley with propeller

E 9325 
Set comprising cord drum with crank, sheave and pawl

E 9326 
Set of wheels with tires

E 9327 
Set of chain links for conveyor belt

E 9328 
Set of chain links for drive chain

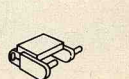
E 9329 
Set of chain links for caterpillar track

E 9330 
Set of connecting building blocks for Märklin plus/Märklin metal construction sets (see page 97)

E 9399 
Base plate · Dimensions 14 7/8" × 15 1/8" (378 × 403 mm)

E 9331  **new**
Set of windows with sliding roller blinds

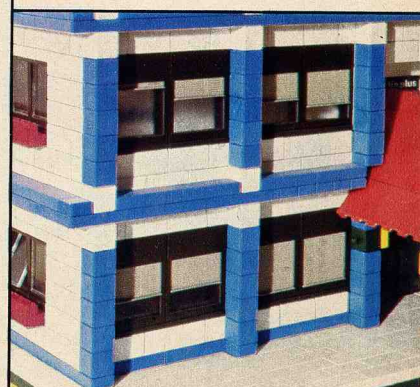

There are exactly the right components to build whatever you have a mind to.

The Märklin plus suggestion for a present

Only a few building blocks are needed to be able to build one of these popular models. These construction kits are favorite items to pick up when you are out shopping and they are ideal as presents on many occasions. All the parts fit in with the other Märklin plus constructional components.

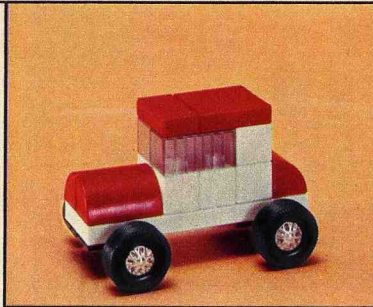

C9200
Old timer kit



C9201
Racing car kit

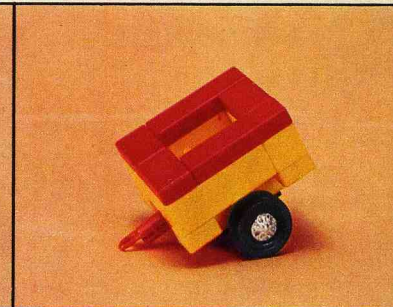

C9202
Trailer kit

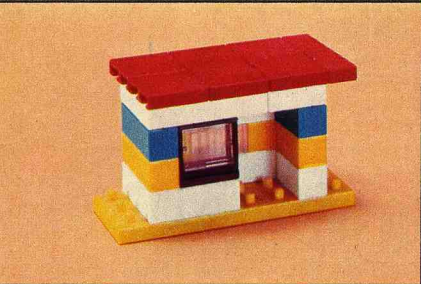

C9220
Bus stop kit



C9221
Tractor kit

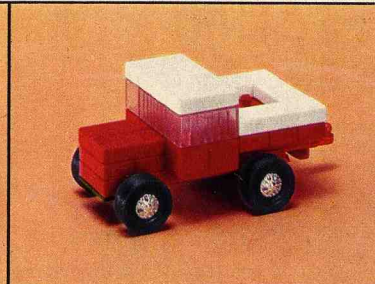

C9222
Commercial vehicle kit

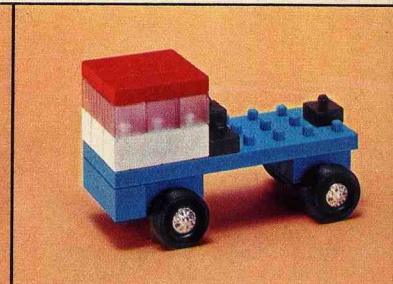

C9223
Semitrailer kit



C9240
House kit



C9241
Landrover kit

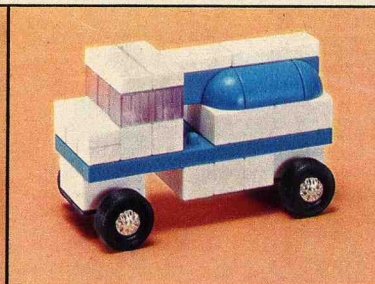

C9242
Road tanker kit



C9243
Truck kit

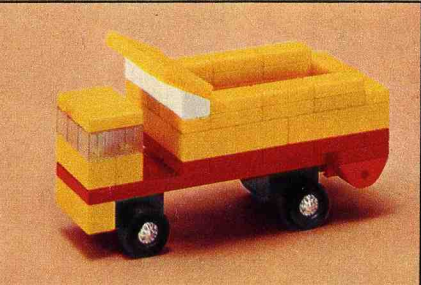

C9287
Tipper kit

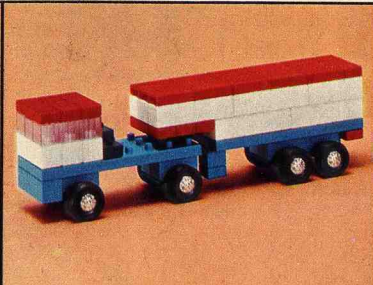

C9288
Articulated tractor and trailer kit



C9289
Road tanker train kit

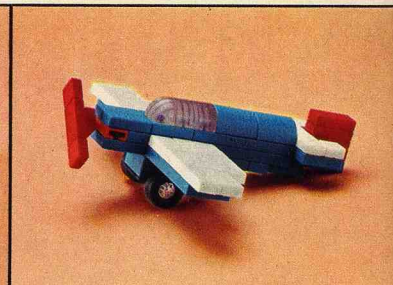

C9290
Aircraft kit

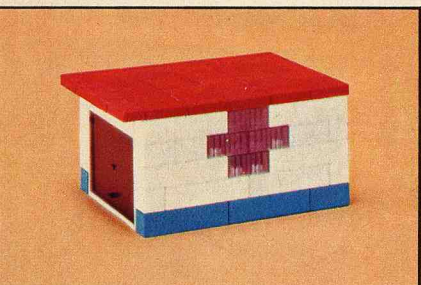

C9298
Garage kit

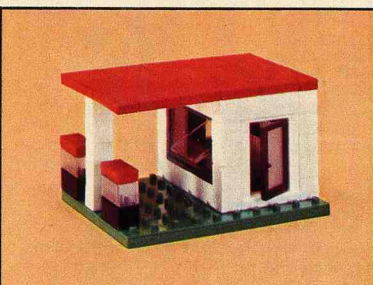

C9299
Gas station kit







Yesterday it was a car, today a house,
tomorrow it will be something different

An exciting hobby

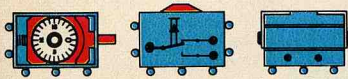
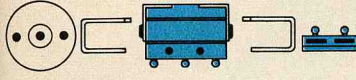
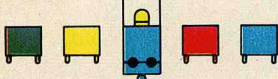
The F series comprise functional parts for the electro-mechanical extension of the B models. Even "junior designers" can prove their value here without any trouble, when they make their models turn, lift and lower, drive and crawl, revolve and curve, climb up and down. There is no finer leisure-time hobby for the schoolboy, the handyman and creative talent which tomorrow will accomplish in reality what today they are trying out with Märklin.

F 9430
Electro-mechanical functional kit · Comprising mechanical and electrical components such as building blocks, shafts, gear wheels, switches, signal lamps, magnets, etc. for constructing electromechanical models · An instruction book is included

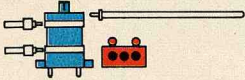

-  **F 9400**
Motor with gearbox
-  **F 9401**
Counter, switch and magnet
-  **F 9402**
Magnet with keeper
-  **F 9403**
Signal lamp with various light covers
-  **F 9404**
Battery box
-  **F 9405**
Single-pole change-over switch
-  **F 9406**
Reversing switch
-  **F 9407**
Mechanical counter
-  **F 9408**
Cam disc

 **F 9409**
Slip-ring

 **F 9410**
Solenoid switch

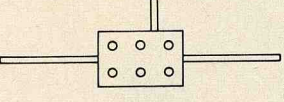
 **F 9411**
Differential

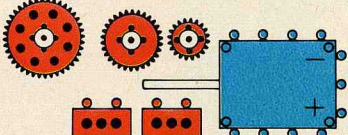
 **F 9412**
Motor with gear wheels

 **F 9413**
Magnet with keeper

 **F 9490**
Set of plugs · Comprising plugs with side sockets, in the colors yellow, green, red and grey

6746
110 Volt

6747
110 Volt USA



6751 220 Volt
Adjustable transformer for A.C. circuit · Circuit I adjustable between 0 and 6 V D.C. · Circuit II constant D.C. voltage of 4 V · Each circuit can be loaded to 1 A · Plastic case · Weight 3 3/4 lbs. (1.7 kg) approx. · Dimensions 5 1/2" x 5" x 3" (136 x 125 x 75 mm)



Traffic light control system, impulse transmitters, electric motors - build them yourself, test them and understand them

Large building blocks for little hands

The blocks are just right for toddlers. Each block also fits precisely in the system as a whole. Understanding and recognition of the world around us comes by picking things up. Playtime means more with Märklin plus: creativeness and the joy which balanced shapes and lively colors bring.



G 9090
 Large building block set · Comprising basic and large building blocks of various sizes and colors



G 9091
 Large building block set · Comprising 1 complete truck chassis together with basic and large building blocks of various sizes and colors



G 9092
 Large building block set · Comprising 2 complete truck chassis together with basic and large building blocks of various sizes and colors



Small hands can best distinguish the big building blocks
 96

... and the most fascinating thing about Märklin plus is the number of models which can be made with Märklin metal construction kits

Combination Märklin plus/metal construction kits

Many successful engineers and technologists have taken their first steps in the world of engineering with the construction set which for many years has been synonymous with engineering construction sets—the Märklin metal construction set.

The two construction systems can now be joined together simply and harmoniously by means of E 9330.

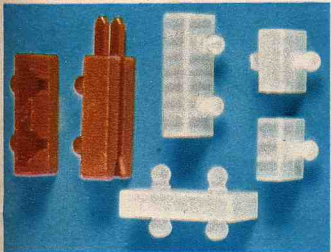

E 9330

Set of connecting building blocks · Comprising six different sorts of building blocks which provide a variety of interesting ways of combining Märklin plus with Märklin metal construction sets (see also page 93)

Examples of combinations Märklin plus with Märklin metal construction sets (see also pages 87—89)

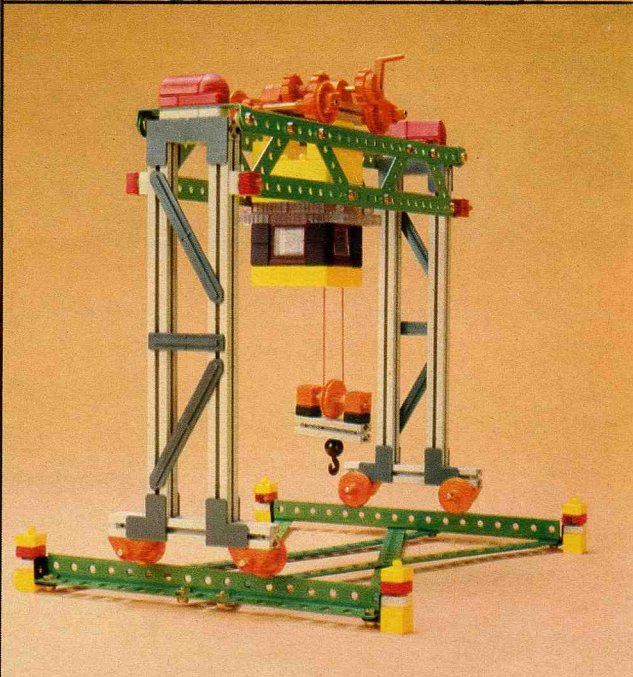
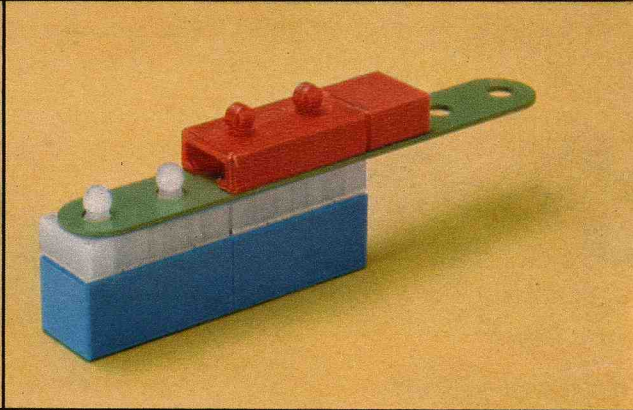
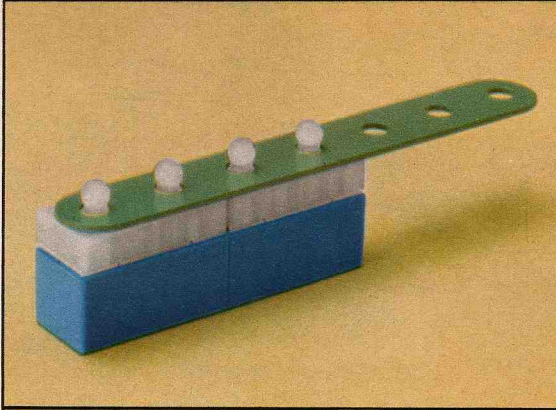
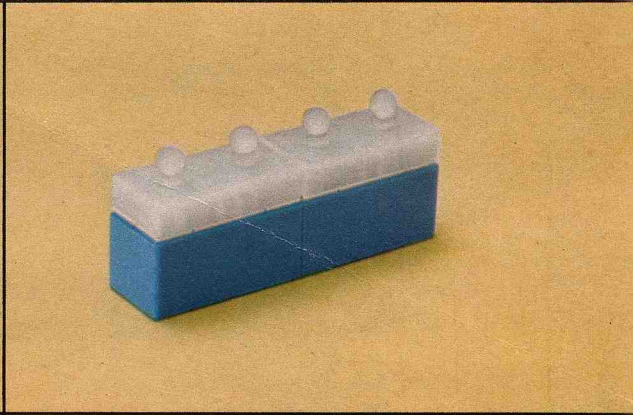
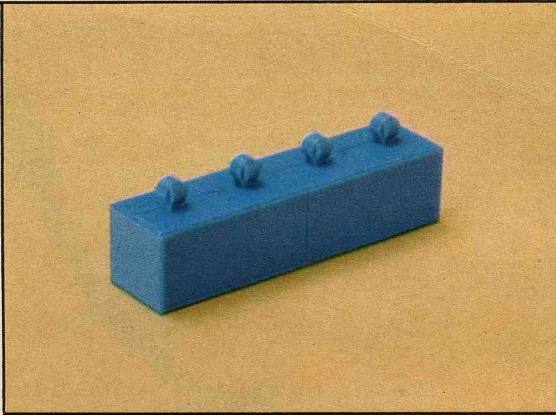

Märklin plus makes seamless joints between metal and plastic, just as today's engineers do.

MÄRKLIN



For Märklin fans: Reprint of the Märklin 1929 catalogue front cover